

BOHN®

MODELOS BLV - JLD

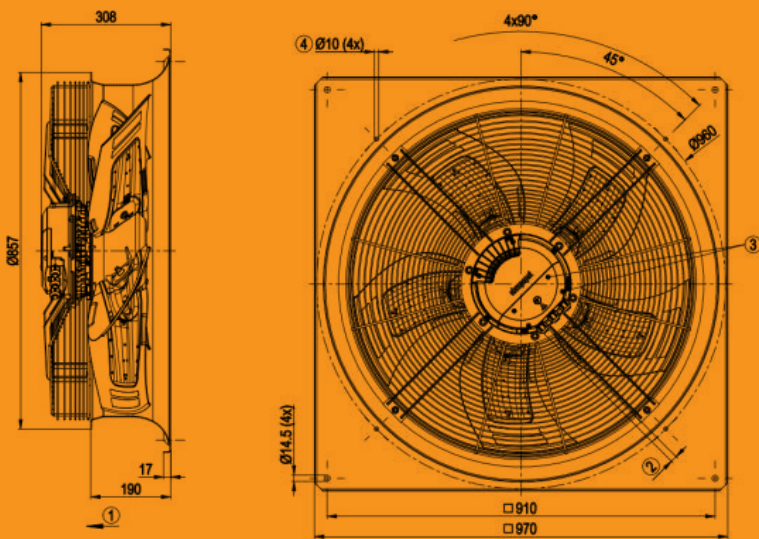

**UNIDADES
CONDENSADORAS**
CONTROL INTELIGENTE
MOTOR 800 MM
12-100 HP



COMPRESORES COPELAND Y BITZER

VENTILADORES EN EL CONDENSADOR

- Media y Baja temperatura.
- Compresores Copeland.
- Compresores reciprocantes tipo semihermético de alta eficiencia.
- Recubrimiento Bohn Gold en su condensador.
- Serpentín-condensador de cobre aluminio con recubrimiento Gold.
- Control inteligente para monitoreo y control.
- 12 a 100 HP.
- Opcional: Condensador Sobredimensionado.

Ventiladores del Condensador

La instalación de **motores de 800 mm electrónicamente conmutados (EC)** mejora la eficiencia y control de los sistemas de refrigeración, con menor consumo energético, menos ruido y un arranque más suave.

El control de velocidad variable mediante PWM **asegura un rendimiento óptimo del condensador y permite ajustar la velocidad según sea necesario**, garantizando un rendimiento superior y una **mayor protección del sistema**.

Beneficios

- **Menor consumo energético:** Operación eficiente que reduce el gasto de energía.
- **Reducción de ruido:** Disminución significativa de los niveles de ruido (dB).
- **Arranque suave:** Minimiza los picos de corriente, protegiendo el sistema.
- **Control de velocidad variable:** Ajuste preciso mediante PWM que optimiza el rendimiento en diferentes condiciones.
- **Protección mejorada:** Integración de componentes como monitores de fases, supresores de picos y fusibles para cada motor, garantizando una operación segura y confiable.



BLV-JLD

UNIDADES
CONDENSADORAS
R-404A/R-507A/R-449A





KE2 en Unidades Condensadoras

- Control del ventilador del condensador con salida análoga para motores de velocidad variable (EC).
- Dispositivo de seguridad para proteger el compresor: contra ciclos cortos, sobrecalentamiento de aspiración baja, alarmas de alta temperatura de aspiración, alta presión y temperatura de descarga.
- Coordinación entre el controlador del evaporador KE2 Evap OEM y la unidad condensadora para evitar ciclos cortos o falta de refrigeración.
- Registro de datos de 30 días, con opción a periodos más largos con KE2-Edge Manager o KE2 SmartAccess.
- Gráfica de presión de succión y descarga con sello de tiempo de 30 días; periodos más largos disponibles.
- Acceso remoto a datos del sistema a través de KE2 SmartAccess, con alcance completo a ambos lados del sistema cuando se usa con KE2 Evap OEM.
- Ajuste remoto de la conexión y desconexión de baja presión, con un control digital preciso
- Información del sobrecalentamiento en la succión y en la descarga
- Protección contra bajo sobrecalentamiento en succión
- Encendido y apagado del sistema de compresión
- Tiempos de operación de compresores, ventiladores y evaporadores.

Puntos de medición con la tarjeta KE2:

Transductores de presión:

1. Succión
2. Descarga

Sensores de temperatura:

3. Succión
4. Descarga
5. Ambiente
6. Líquido

Entrada Digital:

- Estado general de los controles electromecánicos del compresor.

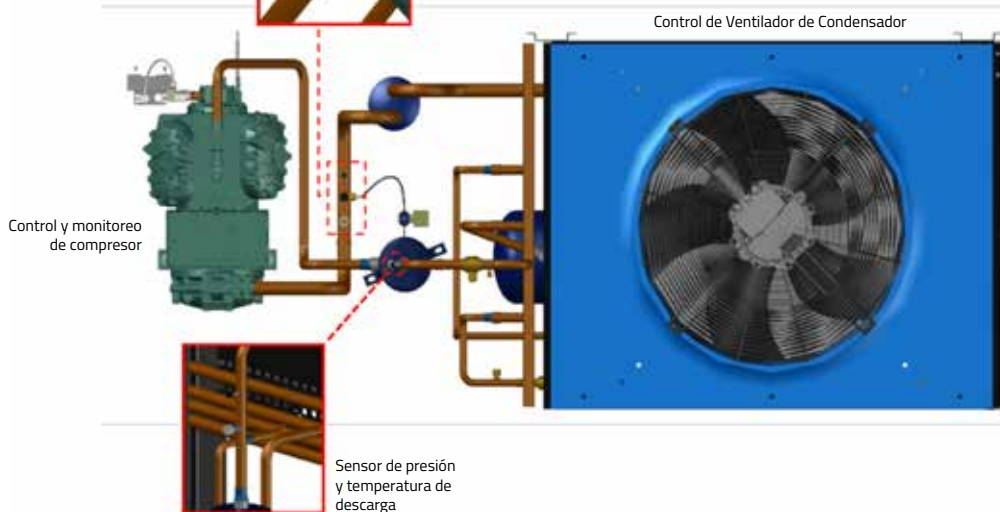
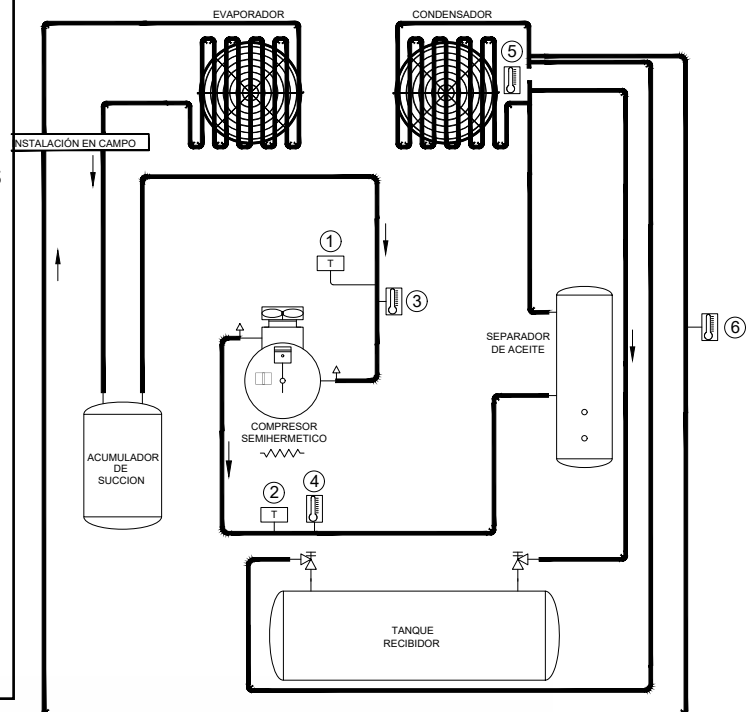

JLD 150 0 L 6 C

Marca
Unidad Condensadora
Marca BOHN
Hecho en México

Potencia Nominal en HP

300: 30 HP	240: 24 HP
400: 40 HP	300: 30 HP
440: 44 HP	360: 36 HP
500: 50 HP	440: 44 HP
600: 60 HP	460: 46 HP
660: 66 HP	540: 54 HP
700: 70 HP	560: 56 HP
800: 80 HP	600: 60 HP
100: 100 HP	680: 68 HP
	880: 88 HP

Compresor
0 - Compresor Copeland
B - Compresor Bitzer

Refrigerante
6: R-404A / R-507A / R-449A

Rango de Aplicación
M: Temp. Media/Alta
L: Temp. Baja

Voltaje
C: 208-230/3/60
D: 460/3/60

BLV 150 0 L 6 C

Marca
Unidad Condensadora
Marca BOHN
Hecho en México

Potencia Nominal en HP

150: 15 HP	120: 12 HP
200: 20 HP	150: 15 HP
220: 22 HP	180: 18 HP
250: 25 HP	220: 22 HP
300: 30 HP	230: 23 HP
330: 33 HP	270: 27 HP
350: 35 HP	280: 28 HP
400: 40 HP	300: 30 HP
500: 50 HP	340: 34 HP
	440: 44 HP

Compresor
0 - Compresor Copeland
B - Compresor Bitzer

Refrigerante
6: R-404A / R-507A / R-449A

Rango de Aplicación
M: Temp. Media/Alta
L: Temp. Baja

Voltaje
C: 208-230/3/60
D: 460/3/60

BLV | DATOS ELÉCTRICOS

MODELO BLV

DATOS ELÉCTRICOS

Modelo Unidad	H.P.	Compresor									Motor Ventilador				
		Compresor	Cant. Comp.	FLA (A)	MCA (A)	MOPD (A)	Voltaje (V/F/Hz)	RLA (A)	LRA (A)	RPMS	Cantidad	Consumo Motor FLA	Ø in (mm)	CAUDAL MÁSIICO (lb/h)	Modelo Ventilador
MEDIA TEMPERATURA Capacidad @ -6.7°C(20°F) de Temperatura de evaporacion															
BLV1500M6C	15	3DS3R17ME-TFC	1	67.2	86.1	110	208-230/3/60	59.6	275	850	2	7.62	31.5 (800)	19,800	W3G800GS2313A
BLV1500M6D	15	3DS3R17ME-TFD	1	32.8	44.1	50	460/3/60	29	138	850	2	3.84	31.5 (800)	19,800	W3G800GS2603C
BLV150BM6C	15	4PES15Y-2NU	1	64.0	82.1	110	208-230/3/60	56.4	294	850	2	7.62	31.5 (800)	19,800	W3G800GS2313A
BLV150BM6D	15	4PES15Y-2NU	1	32.0	43.1	50	460/3/60	28.2	147	850	2	3.84	31.5 (800)	19,800	W3G800GS2603C
BLV2000M6C	20	4DBNR20ME-TSK	1	79.7	101.7	125	208-230/3/60	72.1	374	850	2	7.62	31.5 (800)	19,800	W3G800GS2313A
BLV2000M6D	20	4DBNR20ME-TSK	1	39.9	53	70	460/3/60	36.1	187	850	2	3.84	31.5 (800)	19,800	W3G800GS2603C
BLV200BM6C	20	4NES20Y-2NU	1	74.0	94.6	125	208-230/3/60	66.4	352	850	2	7.62	31.5 (800)	19,800	W3G800GS2313A
BLV200BM6D	20	4NES20Y-2NU	1	37.0	49.3	60	460/3/60	33.2	176	850	2	3.84	31.5 (800)	19,800	W3G800GS2603C
BLV220BM6C	22	4JE22Y-2NU	1	82.0	104.6	125	208-230/3/60	74.4	352	850	2	7.62	31.5 (800)	19,800	W3G800GS2313A
BLV220BM6D	22	4JE22Y-2NU	1	41.0	54.3	70	460/3/60	37.2	176	850	2	3.84	31.5 (800)	19,800	W3G800GS2603C
BLV2500M6C	25	4DHNR22ME-TSK	1	82.0	104.6	125	208-230/3/60	74.4	428	850	2	7.62	31.5 (800)	19,800	W3G800GS2313A
BLV2500M6D	25	4DHNR22ME-TSK	1	41.0	54.3	70	460/3/60	37.2	214	850	2	3.84	31.5 (800)	19,800	W3G800GS2603C
BLV250BM6C	25	4HE25Y-2NU	1	95.6	121.6	150	208-230/3/60	88	261.6	850	2	7.62	31.5 (800)	19,800	W3G800GS2313A
BLV250BM6D	25	4HE25Y-2NU	1	47.8	62.8	80	460/3/60	44	218	850	2	3.84	31.5 (800)	19,800	W3G800GS2603C
BLV3000M6C	30	4DJNR28ME-TSK	1	113.0	143.4	175	208-230/3/60	105.4	292	850	2	7.62	31.5 (800)	19,800	W3G800GS2313A
BLV3000M6D	30	4DJNR28ME-TSK	1	56.5	73.7	100	460/3/60	52.7	235	850	2	3.84	31.5 (800)	19,800	W3G800GS2603C
BLV300BM6C	30	4GE30Y-2NU	1	110.0	139.6	175	208-230/3/60	102.4	294	850	2	7.62	31.5 (800)	19,800	W3G800GS2313A
BLV300BM6D	30	4GE30Y-2NU	1	55.0	71.8	90	460/3/60	51.2	245	850	2	3.84	31.5 (800)	19,800	W3G800GS2603C
BLV330BM6C	33	6JE33Y-2NU	1	117.8	148.4	200	208-230/3/60	106.4	330	850	3	11.4	31.5 (800)	29,700	W3G800GS2313A
BLV330BM6D	33	6JE33Y-2NU	1	59.0	76.3	100	460/3/60	53.2	275	850	3	5.76	31.5 (800)	29,700	W3G800GS2603C
BLV3500M6C	35	6DHNR35ME-TSK	1	136.5	171.8	225	208-230/3/60	125.1	340	850	3	11.4	31.5 (800)	29,700	W3G800GS2313A
BLV3500M6D	35	6DHNR35ME-TSK	1	68.4	88	110	460/3/60	62.6	283	850	3	5.76	31.5 (800)	29,700	W3G800GS2603C
BLV350BM6C	35	6HE35Y-2NU	1	140.2	176.4	225	208-230/3/60	128.8	330	850	3	11.4	31.5 (800)	29,700	W3G800GS2313A
BLV350BM6D	35	6HE35Y-2NU	1	70.2	90.3	110	460/3/60	64.4	275	850	3	5.76	31.5 (800)	29,700	W3G800GS2603C
BLV4000M6C	40	6DJNR40ME-TSK	1	154.3	194.1	250	208-230/3/60	142.9	340	850	3	11.4	31.5 (800)	29,700	W3G800GS2313A
BLV4000M6D	40	6DJNR40ME-TSK	1	77.2	99	125	460/3/60	71.4	297	850	3	5.76	31.5 (800)	29,700	W3G800GS2603C
BLV400BM6C	40	6GE40Y-2NU	1	159.2	200.2	250	208-230/3/60	147.8	419.9	850	3	11.4	31.5 (800)	29,700	W3G800GS2313A
BLV400BM6D	40	6GE40Y-2NU	1	79.7	102.1	125	460/3/60	73.9	350	850	3	5.76	31.5 (800)	29,700	W3G800GS2603C
BLV500BM6C	50	6FE50Y-2NU	1	207.6	259.7	350	208-230/3/60	192.4	570	850	4	15.2	31.5 (800)	39,600	W3G800GS2313A
BLV500BM6D	50	6FE50Y-2NU	1	103.9	131.3	175	460/3/60	96.2	425	850	4	7.68	31.5 (800)	39,600	W3G800GS2603C
BAJA TEMPERATURA Capacidad @ -31.7 °C(-25°F) de Temperatura de evaporacion															
BLV1200L6C	12	4DBNF54KE-TSK	1	58.9	75.7	100	208-230/3/60	51.3	220	850	2	7.62	31.5 (800)	19,800	W3G800GS2313A
BLV1200L6D	12	4DBNF54KE-TSK	1	29.4	39.8	50	460/3/60	25.6	110	850	2	3.84	31.5 (800)	19,800	W3G800GS2603C
BLV1500L6C	15	4DHNF63KE-TSK	1	60.2	77.4	100	208-230/3/60	52.6	278	850	2	7.62	31.5 (800)	19,800	W3G800GS2313A
BLV1500L6D	15	4DHNF63KE-TSK	1	30.1	40.7	50	460/3/60	26.3	139	850	2	3.84	31.5 (800)	19,800	W3G800GS2603C
BLV150BL6C	15	4JE15Y-2NU	1	69.2	88.6	110	208-230/3/60	61.6	352	850	2	7.62	31.5 (800)	19,800	W3G800GS2313A
BLV150BL6D	15	4JE15Y-2NU	1	34.6	46.3	60	460/3/60	30.8	176	850	2	3.84	31.5 (800)	19,800	W3G800GS2603C
BLV180BL6C	18	4HE18Y-2NU	1	81	103.4	125	208-230/3/60	73.4	352	850	2	7.62	31.5 (800)	19,800	W3G800GS2313A
BLV180BL6D	18	4HE18Y-2NU	1	40.5	53.7	70	460/3/60	36.7	176	850	2	3.84	31.5 (800)	19,800	W3G800GS2603C
BLV2200L6C	22	4DJNF76KE-TSK	1	71.9	92	110	208-230/3/60	64.3	374	850	2	7.62	31.5 (800)	19,800	W3G800GS2313A
BLV2200L6D	22	4DJNF76KE-TSK	1	35.9	48	60	460/3/60	32.1	187	850	2	3.84	31.5 (800)	19,800	W3G800GS2603C
BLV230BL6C	23	4GE23Y-2NU	1	95.4	121.4	150	208-230/3/60	87.8	211.2	850	2	7.62	31.5 (800)	19,800	W3G800GS2313A
BLV230BL6D	23	4GE23Y-2NU	1	47.7	62.7	80	460/3/60	43.9	176	850	2	3.84	31.5 (800)	19,800	W3G800GS2603C
BLV2700L6C	27	6DHNF93KE-TSK	1	88.3	112.5	150	208-230/3/60	80.7	263	850	2	7.62	31.5 (800)	19,800	W3G800GS2313A
BLV2700L6D	27	6DHNF93KE-TSK	1	44.2	58.3	70	460/3/60	40.4	225	850	2	3.84	31.5 (800)	19,800	W3G800GS2603C
BLV280BL6C	28	4FE28Y-2NU	1	113.2	143.6	175	208-230/3/60	105.6	294	850	2	7.62	31.5 (800)	19,800	W3G800GS2313A
BLV280BL6D	28	4FE28Y-2NU	1	56.6	73.8	100	460/3/60	52.8	245	850	2	3.84	31.5 (800)	19,800	W3G800GS2603C
BLV3000L6C	30	6DJNF11ME-TSK	1	103.2	131.1	175	208-230/3/60	95.6	292	850	2	7.62	31.5 (800)	19,800	W3G800GS2313A
BLV3000L6D	30	6DJNF11ME-TSK	1	51.6	67.6	90	460/3/60	47.8	235	850	2	3.84	31.5 (800)	19,800	W3G800GS2603C
BLV340BL6C	34	6GE34Y-2NU	1	138.6	175.4	225	208-230/3/60	131	294	850	2	7.62	31.5 (800)	19,800	W3G800GS2313A
BLV340BL6D	34	6GE34Y-2NU	1	69.3	89.7	110	460/3/60	65.5	245	850	2	3.84	31.5 (800)	19,800	W3G800GS2603C
BLV440BL6C	44	6FE44Y-2NU	1	177.8	223.4	300	208-230/3/60	166.4	419.9	850	3	11.4	31.5 (800)	29,700	W3G800GS2313A
BLV440BL6D	44	6FE44Y-2NU	1	89	113.8	150	460/3/60	83.2	350	850	3	5.76	31.5 (800)	29,700	W3G800GS2603C

Modelo Unidad	H.P.	Compresor								Motor Ventilador					
		Compresor	Cant. Comp.	FLA (A)	MCA (A)	MOPD (A)	Voltaje (V/F/Hz)	RLA (A)	LRA (A)	RPMS	Canti- dad	Consumo Motor FLA	Ø in (mm)	CAUDAL MÁSICO (lb/h)	Modelo Ventilador
MEDIA TEMPERATURA															
JLD3000M6C	30	3DS3R17ME-TFC	2	134.4	153.3	175	208-230/3/60	59.6	275	850	4	15.2	31.5 (800)	39600	W3G800GS2313A
JLD3000M6D	30	3DS3R17ME-TFD	2	65.7	76.9	90	460/3/60	29	138	850	4	7.68	31.5 (800)	39600	W3G800GS2603C
JLD300BM6C	30	4PES15Y-2NU	2	128.0	146.1	150	208-230/3/60	56.4	294	850	4	15.2	31.5 (800)	39600	W3G800GS2313A
JLD300BM6D	30	4PES15Y-2NU	2	64.1	75.1	80	460/3/60	28.2	147	850	4	7.68	31.5 (800)	39600	W3G800GS2603C
JLD4000M6C	40	4DBNR20ME-TSK	2	159.4	181.5	200	208-230/3/60	72.1	374	850	4	15.2	31.5 (800)	39600	W3G800GS2313A
JLD4000M6D	40	4DBNR20ME-TSK	2	79.9	92.9	100	460/3/60	36.1	187	850	4	7.68	31.5 (800)	39600	W3G800GS2603C
JLD400BM6C	40	4NES20-2NU	2	148.0	168.6	175	208-230/3/60	66.4	352	850	4	15.2	31.5 (800)	39600	W3G800GS2313A
JLD400BM6D	40	4NES20-2NU	2	74.1	86.4	100	460/3/60	33.2	176	850	4	7.68	31.5 (800)	39600	W3G800GS2603C
JLD440BM6C	44	4JE22Y-2NU	2	164.0	186.6	200	208-230/3/60	74.4	352	850	4	15.2	31.5 (800)	39600	W3G800GS2313A
JLD440BM6D	44	4JE22Y-2NU	2	82.1	95.4	110	460/3/60	37.2	176	850	4	7.68	31.5 (800)	39600	W3G800GS2603C
JLD5000M6C	50	4DHR22ME-TSK	2	164.0	186.6	200	208-230/3/60	74.4	428	850	4	15.2	31.5 (800)	39600	W3G800GS2313A
JLD5000M6D	50	4DHR22ME-TSK	2	82.1	95.4	110	460/3/60	37.2	214	850	4	7.68	31.5 (800)	39600	W3G800GS2603C
JLD500BM6C	50	4HE25Y-2NU	2	191.2	217.2	250	208-230/3/60	88.0	261.6	850	4	15.2	31.5 (800)	39600	W3G800GS2313A
JLD500BM6D	50	4HE25Y-2NU	2	95.7	110.7	125	460/3/60	44.0	218	850	4	7.68	31.5 (800)	39600	W3G800GS2603C
JLD6000M6C	60	4DJNR28ME-TSK	2	226.0	256.4	300	208-230/3/60	105.4	292	850	4	15.2	31.5 (800)	39600	W3G800GS2313A
JLD6000M6D	60	4DJNR28ME-TSK	2	113.1	130.3	150	460/3/60	52.7	235	850	4	7.68	31.5 (800)	39600	W3G800GS2603C
JLD600BM6C	60	4GE-30-2NU	2	220.0	249.6	300	208-230/3/60	102.4	294	850	4	15.2	31.5 (800)	39600	W3G800GS2313A
JLD600BM6D	60	4GE-30-2NU	2	110.1	126.9	150	460/3/60	51.2	245	850	4	7.68	31.5 (800)	39600	W3G800GS2603C
JLD660BM6C	66	6JE33Y-2NU	2	235.7	266.3	300	208-230/3/60	106.4	330	850	6	22.9	31.5 (800)	59400	W3G800GS2313A
JLD660BM6D	66	6JE33Y-2NU	2	117.9	135.2	150	460/3/60	53.2	275	850	6	11.5	31.5 (800)	59400	W3G800GS2603C
JLD7000M6C	70	6DHR35ME-TSK	2	273.1	308.3	350	208-230/3/60	125.1	340	850	6	22.9	31.5 (800)	59400	W3G800GS2313A
JLD7000M6D	70	6DHR35ME-TSK	2	136.7	156.4	175	460/3/60	62.6	283	850	6	11.5	31.5 (800)	59400	W3G800GS2603C
JLD700BM6C	70	6HE35Y-2NU	2	280.5	316.7	350	208-230/3/60	128.8	330	850	6	22.9	31.5 (800)	59400	W3G800GS2313A
JLD700BM6D	70	6HE35Y-2NU	2	140.3	160.4	175	460/3/60	64.4	275	850	6	11.5	31.5 (800)	59400	W3G800GS2603C
JLD8000M6C	80	6DJNR40ME-TSK	2	308.7	348.4	400	208-230/3/60	142.9	340	850	6	22.9	31.5 (800)	59400	W3G800GS2313A
JLD8000M6D	80	6DJNR40ME-TSK	2	154.3	176.2	200	460/3/60	71.4	297	850	6	11.5	31.5 (800)	59400	W3G800GS2603C
JLD800BM6C	80	6GE40Y-2NU	2	318.5	359.4	400	208-230/3/60	147.8	419.9	850	6	22.9	31.5 (800)	59400	W3G800GS2313A
JLD800BM6D	80	6GE40Y-2NU	2	159.3	181.8	200	460/3/60	73.9	350	850	6	11.5	31.5 (800)	59400	W3G800GS2603C
JLD1000BM6C	100	6FE50Y-2NU	2	415.3	467.4	500	208-230/3/60	192.4	570	850	8	30.5	31.5 (800)	79200	W3G800GS2313A
JLD1000BM6D	100	6FE50Y-2NU	2	207.8	235.8	250	460/3/60	96.2	425	850	8	15.4	31.5 (800)	79200	W3G800GS2603C
BAJA TEMPERATURA															
JLD2400L6C	24	4DBNF54KE-TSK	2	117.8	134.7	150	208-230/3/60	51.3	220	850	4	15.2	31.5 (800)	39600	W3G800GS2313A
JLD2400L6D	24	4DBNF54KE-TSK	2	58.9	69.3	80	460/3/60	25.6	110	850	4	7.68	31.5 (800)	39600	W3G800GS2603C
JLD3000L6C	30	4DHNF63KE-TSK	2	120.4	137.6	150	208-230/3/60	52.6	278	850	4	15.2	31.5 (800)	39600	W3G800GS2313A
JLD3000L6D	30	4DHNF63KE-TSK	2	60.3	70.9	80	460/3/60	26.3	139	850	4	7.68	31.5 (800)	39600	W3G800GS2603C
JLD300BL6C	30	4JE15Y-2NU	2	138.4	157.8	175	208-230/3/60	61.6	352	850	4	15.2	31.5 (800)	39600	W3G800GS2313A
JLD300BL6D	30	4JE15Y-2NU	2	69.3	81.0	90	460/3/60	30.8	176	850	4	7.68	31.5 (800)	39600	W3G800GS2603C
JLD360BL6C	36	4HE18Y-2NU	2	162.0	184.4	200	208-230/3/60	73.4	352	850	4	15.2	31.5 (800)	39600	W3G800GS2313A
JLD360BL6D	36	4HE18Y-2NU	2	81.1	94.3	110	460/3/60	36.7	176	850	4	7.68	31.5 (800)	39600	W3G800GS2603C
JLD4400L6C	44	4DJNF76KE-TSK	2	143.8	163.9	175	208-230/3/60	64.3	374	850	4	15.2	31.5 (800)	39600	W3G800GS2313A
JLD4400L6D	44	4DJNF76KE-TSK	2	71.9	83.9	90	460/3/60	32.1	187	850	4	7.68	31.5 (800)	39600	W3G800GS2603C
JLD460BL6C	46	4GE23Y-2NU	2	190.8	216.8	250	208-230/3/60	87.8	211.2	850	4	15.2	31.5 (800)	39600	W3G800GS2313A
JLD460BL6D	46	4GE23Y-2NU	2	95.5	110.5	125	460/3/60	43.9	176	850	4	7.68	31.5 (800)	39600	W3G800GS2603C
JLD5400L6C	54	6DHNF93KE-TSK	2	176.6	200.8	225	208-230/3/60	80.7	263	850	4	15.2	31.5 (800)	39600	W3G800GS2313A
JLD5400L6D	54	6DHNF93KE-TSK	2	88.5	102.6	110	460/3/60	40.4	225	850	4	7.68	31.5 (800)	39600	W3G800GS2603C
JLD560BL6C	56	4FE28Y-2NU	2	226.4	256.8	300	208-230/3/60	105.6	294	850	4	15.2	31.5 (800)	39600	W3G800GS2313A
JLD560BL6D	56	4FE28Y-2NU	2	113.3	130.5	150	460/3/60	52.8	245	850	4	7.68	31.5 (800)	39600	W3G800GS2603C
JLD6000L6C	60	6DJNF11ME-TSK	2	206.4	234.3	250	208-230/3/60	95.6	292	850	4	15.2	31.5 (800)	39600	W3G800GS2313A
JLD6000L6D	60	6DJNF11ME-TSK	2	103.3	119.2	125	460/3/60	47.8	235	850	4	7.68	31.5 (800)	39600	W3G800GS2603C
JLD680BL6C	68	6GE34Y-2NU	2	277.2	314.0	350	208-230/3/60	131.0	294	850	4	15.2	31.5 (800)	39600	W3G800GS2313A
JLD680BL6D	68	6GE34Y-2NU	2	138.7	159.1	175	460/3/60	65.5	245	850	4	7.68	31.5 (800)	39600	W3G800GS2603C
JLD880BL6C	88	6FE44Y-2NU	2	355.7	401.3	450	208-230/3/60	166.4	419.9	850	6	22.9	31.5 (800)	59400	W3G800GS2313A
JLD880BL6D	88	6FE44Y-2NU	2	177.9	202.7	225	460/3/60	83.2	350	850	6	11.5	31.5 (800)	59400	W3G800GS2603C

Modelo	Vent.	Desp. Vol. in ³ /rev	Flujo Másico CFM	Conexiones (DI) pulg		Recibidor Cap. al 90%		CONDENSADOR ESTÁNDAR							
				Succión	Líquido	Lbs	Kgs	Largo		Ancho		Alto		Peso	
								cm	pulg	cm	pulg	cm	pulg	Kg	Lbs
MEDIA TEMPERATURA															
BLV1500M6C	2	35.07	35	1 5/8	7/8	150	68	434	171	112	44.4	155	61	727	1602
BLV1500M6D	2	35.07	35	1 5/8	7/8	150	68	434	171	112	44.4	155	61	727	1602
BLV150BM6C	2	33.97	34	1 5/8	7/8	150	68	434	171	112	44.4	155	61	645	1422
BLV150BM6D	2	33.97	34	1 5/8	7/8	150	68	434	171	112	44.4	155	61	645	1422
BLV2000M6C	2	43.39	46	2 1/8	7/8	150	68	434	171	112	44.4	155	61	727	1602
BLV2000M6D	2	43.39	46	2 1/8	7/8	150	68	434	171	112	44.4	155	61	727	1602
BLV200BM6C	2	39.49	40	1 5/8	7/8	150	68	434	171	112	44.4	155	61	747	1647
BLV200BM6D	2	39.49	40	1 5/8	7/8	150	68	434	171	112	44.4	155	61	747	1647
BLV220BM6C	2	44.68	45	1 5/8	7/8	150	68	434	171	112	44.4	155	61	777	1712
BLV220BM6D	2	44.68	45	1 5/8	7/8	150	68	434	171	112	44.4	155	61	777	1712
BLV2500M6C	2	50.24	50	2 1/8	1 1/8	150	68	434	171	112	44.4	155	61	749	1652
BLV2500M6D	2	50.24	50	2 1/8	1 1/8	150	68	434	171	112	44.4	155	61	749	1652
BLV250BM6C	2	51.93	52	2 1/8	1 1/8	150	68	434	171	112	44.4	155	61	888	1957
BLV250BM6D	2	51.93	52	2 1/8	1 1/8	150	68	434	171	112	44.4	155	61	888	1957
BLV3000M6C	2	61.66	60	2 1/8	1 1/8	150	68	434	171	112	44.4	155	61	854	1882
BLV3000M6D	2	61.66	60	2 1/8	1 1/8	150	68	434	171	112	44.4	155	61	854	1882
BLV300BM6C	2	59.33	60	2 1/8	1 1/8	150	68	434	171	112	44.4	155	61	743	1637
BLV300BM6D	2	59.33	60	2 1/8	1 1/8	150	68	434	171	112	44.4	155	61	743	1637
BLV330BM6C	3	67.02	68	2 1/8	1 1/8	150	68	573	225	112	44.4	155	61	825	1818
BLV330BM6D	3	67.02	68	2 1/8	1 1/8	150	68	573	225	112	44.4	155	61	825	1818
BLV3500M6C	3	74.68	69	2 1/8	1 1/8	150	68	573	225	112	44.4	155	61	1040	2293
BLV3500M6D	3	74.68	69	2 1/8	1 1/8	150	68	573	225	112	44.4	155	61	1040	2293
BLV350BM6C	3	77.9	78	2 1/8	1 1/8	150	68	573	225	112	44.4	155	61	870	1918
BLV350BM6D	3	77.9	78	2 1/8	1 1/8	150	68	573	225	112	44.4	155	61	870	1918
BLV4000M6C	3	89.2	90	2 1/8	1 1/8	150	68	573	225	112	44.4	155	61	1085	2393
BLV4000M6D	3	89.2	90	2 1/8	1 1/8	150	68	573	225	112	44.4	155	61	1085	2393
BLV400BM6C	3	88.99	90	2 1/8	1 1/8	150	68	573	225	112	44.4	155	61	1122	2473
BLV400BM6D	3	88.99	90	2 1/8	1 1/8	150	68	573	225	112	44.4	155	61	1122	2473
BLV500BM6C	4	106.69	108	2 1/8	1 1/8	150	68	711	280	112	44.4	160	63	1306	2879
BLV500BM6D	4	106.69	108	2 1/8	1 1/8	150	68	711	280	112	44.4	160	63	1306	2879
BAJA TEMPERATURA															
BLV1200L6C	2	43.39	44	1 5/8	7/8	150	68	434	171	112	44.4	155	61	690	1522
BLV1200L6D	2	43.39	44	1 5/8	7/8	150	68	434	171	112	44.4	155	61	690	1522
BLV1500L6C	2	33.97	34	1 5/8	7/8	150	68	434	171	112	44.4	155	61	690	1522
BLV1500L6D	2	33.97	34	1 5/8	7/8	150	68	434	171	112	44.4	155	61	690	1522
BLV150BL6C	2	39.49	40	1 5/8	7/8	150	68	434	171	112	44.4	155	61	731	1612
BLV150BL6D	2	39.49	40	1 5/8	7/8	150	68	434	171	112	44.4	155	61	731	1612
BLV180BL6C	2	50.24	50	1 5/8	7/8	150	68	434	171	112	44.4	155	61	826	1822
BLV180BL6D	2	50.24	50	1 5/8	7/8	150	68	434	171	112	44.4	155	61	826	1822
BLV2200L6C	2	51.93	52	2 1/8	7/8	150	68	434	171	112	44.4	155	61	690	1522
BLV2200L6D	2	51.93	52	2 1/8	7/8	150	68	434	171	112	44.4	155	61	690	1522
BLV230BL6C	2	59.47	60	2 1/8	7/8	150	68	434	171	112	44.4	155	61	858	1892
BLV230BL6D	2	59.47	60	2 1/8	7/8	150	68	434	171	112	44.4	155	61	858	1892
BLV2700L6C	2	74.68	75	2 1/8	1 1/8	150	68	434	171	112	44.4	155	61	768	1692
BLV2700L6D	2	74.68	75	2 1/8	1 1/8	150	68	434	171	112	44.4	155	61	768	1692
BLV280BL6C	2	70.68	71	2 1/8	1 1/8	150	68	434	171	112	44.4	155	61	994	2192
BLV280BL6D	2	70.68	71	2 1/8	1 1/8	150	68	434	171	112	44.4	155	61	994	2192
BLV3000L6C	2	89.2	90	2 1/8	1 1/8	150	68	434	171	112	44.4	155	61	858	1892
BLV3000L6D	2	89.2	90	2 1/8	1 1/8	150	68	434	171	112	44.4	155	61	858	1892
BLV340BL6C	2	88.99	90	2 1/8	1 1/8	150	68	434	171	112	44.4	155	61	999	2202
BLV340BL6D	2	88.99	90	2 1/8	1 1/8	150	68	434	171	112	44.4	155	61	999	2202
BLV440BL6C	3	106.69	108	2 1/8	1 1/8	150	68	573	225	112	44.4	155	61	886	1953
BLV440BL6D	3	106.69	108	2 1/8	1 1/8	150	68	573	225	112	44.4	155	61	886	1953

Modelo	Vent.	Desp. Vol. in3/rev	Flujo		Conexiones (DI)		Recibidor		CONDENSADOR ESTÁNDAR									
			Másico CFM	Succión	pulg	Líquido	7/8	150	Cap. al 90%		Largo		Ancho		Alto		Peso	
									Lbs	Kgs	cm	pulg	cm	pulg	cm	pulg	Kg	Lbs
MEDIA TEMPERATURA																		
JLD3000M6C	4	35.07	35	1 5/8	7/8	150	68	434	171	222	87	155	61	1453	3204			
JLD3000M6D	4	35.07	35	1 5/8	7/8	150	68	434	171	222	87	155	61	1453	3204			
JLD300BM6C	4	33.97	34	1 5/8	7/8	150	68	434	171	222	87	155	61	1292	2849			
JLD300BM6D	4	33.97	34	1 5/8	7/8	150	68	434	171	222	87	155	61	1292	2849			
JLD4000M6C	4	43.39	46	2 1/8	7/8	150	68	434	171	222	87	155	61	1453	3204			
JLD4000M6D	4	43.39	46	2 1/8	7/8	150	68	434	171	222	87	155	61	1453	3204			
JLD400BM6C	4	39.49	40	1 5/8	7/8	150	68	434	171	222	87	155	61	1494	3294			
JLD400BM6D	4	39.49	40	1 5/8	7/8	150	68	434	171	222	87	155	61	1494	3294			
JLD440BM6C	4	44.68	45	1 5/8	7/8	150	68	434	171	222	87	155	61	1553	3424			
JLD440BM6D	4	44.68	45	1 5/8	7/8	150	68	434	171	222	87	155	61	1553	3424			
JLD5000M6C	4	50.24	50	2 1/8	1-1/8"	145	65.6	434	171	222	87	155	61	1485	3274			
JLD5000M6D	4	50.24	50	2 1/8	1-1/8"	145	65.6	434	171	222	87	155	61	1485	3274			
JLD500BM6C	4	51.93	52	2 1/8	1-1/8"	145	65.6	434	171	222	87	155	61	1778	3919			
JLD500BM6D	4	51.93	52	2 1/8	1-1/8"	145	65.6	434	171	222	87	155	61	1778	3919			
JLD6000M6C	4	61.66	60	2 1/8	1-1/8"	145	65.6	434	171	222	87	155	61	1707	3764			
JLD6000M6D	4	61.66	60	2 1/8	1-1/8"	145	65.6	434	171	222	87	155	61	1707	3764			
JLD600BM6C	4	59.33	60	2 1/8	1-1/8"	145	65.6	434	171	222	87	155	61	1483	3269			
JLD600BM6D	4	59.33	60	2 1/8	1-1/8"	145	65.6	434	171	222	87	155	61	1483	3269			
JLD660BM6C	6	67.02	68	2 1/8	1-1/8"	145	65.6	573	225	222	87	156	61	1649	3636			
JLD660BM6D	6	67.02	68	2 1/8	1-1/8"	145	65.6	573	225	222	87	156	61	1649	3636			
JLD7000M6C	6	74.68	69	2 1/8	1-1/8"	145	65.6	573	225	222	87	156	61	1990	4386			
JLD7000M6D	6	74.68	69	2 1/8	1-1/8"	145	65.6	573	225	222	87	156	61	1990	4386			
JLD700BM6C	6	77.9	78	2 1/8	1-1/8"	145	65.6	573	225	222	87	156	61	1740	3836			
JLD700BM6D	6	77.9	78	2 1/8	1-1/8"	145	65.6	573	225	222	87	156	61	1740	3836			
JLD8000M6C	6	89.2	90	2 1/8	1-1/8"	145	65.6	573	225	222	87	156	61	2189	4826			
JLD8000M6D	6	89.2	90	2 1/8	1-1/8"	145	65.6	573	225	222	87	156	61	2189	4826			
JLD800BM6C	6	88.99	90	2 1/8	1-1/8"	145	65.6	573	225	222	87	156	61	2244	4946			
JLD800BM6D	6	88.99	90	2 1/8	1-1/8"	145	65.6	573	225	222	87	156	61	2244	4946			
JLD1000BM6C	8	106.69	108	2 1/8	1-1/8"	145	65.6	172	280	222	87	156	61	2612	5758			
JLD1000BM6D	8	106.69	108	2 1/8	1-1/8"	145	65.6	172	280	222	87	156	61	2612	5758			
BAJA TEMPERATURA																		
JLD2400L6C	4	43.39	44	1 5/8	7/8	145	65.6	434	171	222	87	155	61	1381	3044			
JLD2400L6D	4	43.39	44	1 5/8	7/8	145	65.6	434	171	222	87	155	61	1381	3044			
JLD3000L6C	4	33.97	34	1 5/8	7/8	145	65.6	434	171	222	87	155	61	1381	3044			
JLD3000L6D	4	33.97	34	1 5/8	7/8	145	65.6	434	171	222	87	155	61	1381	3044			
JLD300BL6C	4	39.49	40	1 5/8	7/8	145	65.6	434	171	222	87	155	61	1460	3219			
JLD300BL6D	4	39.49	40	1 5/8	7/8	145	65.6	434	171	222	87	155	61	1460	3219			
JLD360BL6C	4	50.24	50	1 5/8	7/8	145	65.6	434	171	222	87	155	61	1655	3649			
JLD360BL6D	4	50.24	50	1 5/8	7/8	145	65.6	434	171	222	87	155	61	1655	3649			
JLD4400L6C	4	51.93	52	2 1/8	7/8	145	65.6	434	171	222	87	155	61	1381	3044			
JLD4400L6D	4	51.93	52	2 1/8	7/8	145	65.6	434	171	222	87	155	61	1381	3044			
JLD460BL6C	4	59.47	60	2 1/8	7/8	145	65.6	434	171	222	87	155	61	1714	3779			
JLD460BL6D	4	59.47	60	2 1/8	7/8	145	65.6	434	171	222	87	155	61	1714	3779			
JLD5400L6C	4	74.68	75	2 1/8	1-1/8"	145	65.6	434	171	222	87	155	61	1730	3814			
JLD5400L6D	4	74.68	75	2 1/8	1-1/8"	145	65.6	434	171	222	87	155	61	1730	3814			
JLD560BL6C	4	70.68	71	2 1/8	1-1/8"	145	65.6	434	171	222	87	155	61	1943	4284			
JLD560BL6D	4	70.68	71	2 1/8	1-1/8"	145	65.6	434	171	222	87	155	61	1943	4284			
JLD6000L6C	4	89.2	90	2 1/8	1-1/8"	145	65.6	434	171	222	87	155	61	1730	3814			
JLD6000L6D	4	89.2	90	2 1/8	1-1/8"	145	65.6	434	171	222	87	155	61	1730	3814			
JLD680BL6C	4	88.99	90	2 1/8	1-1/8"	145	65.6	434	171	222	87	155	61	1995	4399			
JLD680BL6D	4	88.99	90	2 1/8	1-1/8"	145	65.6	434	171	222	87	155	61	1995	4399			
JLD880BL6C	6	106.69	108	2 1/8	1-1/8"	145	65.6	573	225	222	87	156	61	1770	3901			
JLD880BL6D	6	106.69	108	2 1/8	1-1/8"	145	65.6	573	225	222	87	156	61	1770	3901			

Modelo	Compresor	H.P	TSC (°F)	TSE °F C=Capacidad kBtu's/h P=Potencia kW A= Amps.													
				-5	0	5	10	15	20	25	30	35	40	45			
BLV150BM6D	4PES-15Y	15	130	C	36.5	43.6	51.6	60.6	70.6	81.9	94.5	108.5	124.0	141.0	159.7		
				P	8.4	9.3	10.2	11.0	11.8	12.6	13.3	14.0	14.6	15.2	15.7		
				A	14.6	15.4	16.3	17.2	18.1	19.0	19.8	20.6	21.4	22.1	22.7		
			120	C	43.3	51.2	60.0	70.0	81.1	93.4	107.1	122.3	139.0	157.4	177.5		
				P	8.4	9.2	10.0	10.8	11.5	12.1	12.7	13.3	13.8	14.3	14.7		
				A	14.6	15.4	16.1	16.9	17.7	18.4	19.2	19.8	20.4	21.0	21.5		
		110	C	50.2	58.9	68.6	79.5	91.6	105.0	119.9	136.2	154.1	173.8	195.3			
			P	8.4	9.1	9.8	10.4	11.0	11.6	12.1	12.5	12.9	13.3	13.5			
			A	14.5	15.2	15.9	16.5	17.2	17.8	18.4	18.9	19.4	19.8	20.1			
		100	C	57.3	66.8	77.4	89.2	102.2	116.7	132.7	150.2	169.4	190.3	213.1			
			P	8.2	8.8	9.4	9.9	10.4	10.9	11.3	11.7	11.9	12.2	12.3			
			A	14.3	14.9	15.5	16.0	16.6	17.1	17.5	17.9	18.3	18.5	18.7			
		90	C	64.4	74.7	86.2	98.9	113.0	128.5	145.5	164.2	184.7	206.9	231.1			
			P	7.9	8.4	8.9	9.4	9.8	10.1	10.4	10.6	10.8	10.9	10.9			
			A	14.0	14.5	15.0	15.5	15.9	16.3	16.6	16.8	17.0	17.1	17.1			
		BLV200BM6D	4NES-20Y	20	130	C	46.6	55.0	64.3	74.9	86.8	100.0	114.7	131.0	149.1	169.0	190.8
						P	10.3	11.3	12.3	13.2	14.1	14.9	15.8	16.5	17.2	17.9	18.4
						A	16.8	17.8	18.8	19.8	20.8	21.8	22.8	23.7	24.6	25.4	26.1
120	C				54.4	63.6	74.0	85.6	98.6	113.1	129.1	146.8	166.2	187.6	211.0		
	P				10.2	11.1	12.0	12.8	13.6	14.4	15.0	15.7	16.3	16.8	17.2		
	A				16.7	17.6	18.5	19.4	20.3	21.1	21.9	22.7	23.4	24.0	24.6		
110	C			62.2	72.4	83.8	96.5	110.6	126.2	143.5	162.5	183.4	206.3	231.2			
	P			10.0	10.8	11.6	12.3	13.0	13.6	14.2	14.7	15.2	15.5	15.8			
	A			16.5	17.3	18.1	18.8	19.6	20.3	20.9	21.5	22.1	22.5	22.9			
100	C			70.1	81.2	93.6	107.3	122.6	139.5	158.0	178.4	200.7	225.1	251.6			
	P			9.8	10.5	11.1	11.7	12.3	12.8	13.3	13.6	14.0	14.2	14.3			
	A			16.2	16.9	17.6	18.2	18.8	19.4	19.9	20.3	20.7	21.0	21.1			
90	C			78.1	90.1	103.5	118.3	134.7	152.8	172.6	194.3	218.1	243.9	272.0			
	P			9.4	10.0	10.5	11.0	11.5	11.9	12.2	12.4	12.6	12.7	12.7			
	A			15.9	16.4	17.0	17.5	18.0	18.4	18.7	19.0	19.2	19.3	19.3			
BLV220BM6D	4JE-22Y			22	130	C	52.1	61.7	72.5	84.4	97.7	112.4	128.7	146.7	166.4	188.0	211.7
						P	12.0	13.0	14.1	15.1	16.1	17.0	17.9	18.8	19.6	20.4	21.1
						A	18.5	19.7	20.8	22.0	23.2	24.3	25.4	26.5	27.6	28.6	29.5
		120	C		61.3	71.9	83.7	96.7	111.2	127.2	144.8	164.2	185.4	208.6	233.8		
			P		11.8	12.7	13.7	14.6	15.5	16.3	17.1	17.9	18.6	19.2	19.8		
			A		18.3	19.3	20.4	21.4	22.5	23.5	24.4	25.4	26.3	27.1	27.9		
		110	C	70.4	82.0	94.8	109.0	124.6	141.9	160.8	181.6	204.3	228.9	255.8			
			P	11.5	12.3	13.2	14.0	14.8	15.5	16.2	16.8	17.4	17.9	18.4			
			A	18.0	18.9	19.8	20.7	21.6	22.5	23.3	24.1	24.8	25.5	26.0			
		100	C	79.5	92.0	105.8	121.1	137.9	156.4	176.6	198.8	222.9	249.1	277.5			
			P	11.1	11.9	12.6	13.3	14.0	14.6	15.2	15.7	16.1	16.5	16.8			
			A	17.6	18.4	19.2	19.9	20.7	21.4	22.1	22.7	23.2	23.7	24.1			
		90	C	88.5	101.9	116.8	133.1	151.0	170.7	192.2	215.7	241.2	268.9	298.9			
			P	10.6	11.3	11.9	12.5	13.1	13.5	14.0	14.4	14.7	14.9	15.1			
			A	17.1	17.8	18.4	19.1	19.7	20.2	20.7	21.2	21.5	21.8	22.0			
		BLV250BM6D	4HE-25Y	25	130	C	64.1	75.2	87.6	101.3	116.6	133.5	152.2	172.8	195.5	220.3	247.4
						P	14.8	15.9	17.1	18.2	19.3	20.3	21.4	22.3	23.2	24.1	24.8
						A	23.4	24.7	26.0	27.3	28.5	29.8	31.0	32.2	33.3	34.4	35.4
120	C				74.6	86.8	100.4	115.5	132.2	150.7	171.0	193.3	217.7	244.4	273.4		
	P				14.4	15.4	16.5	17.5	18.5	19.4	20.3	21.2	21.9	22.6	23.3		
	A				23.0	24.2	25.3	26.5	27.6	28.7	29.8	30.8	31.7	32.6	33.4		
110	C			85.0	98.4	113.2	129.6	147.7	167.6	189.5	213.4	239.6	268.1	299.0			
	P			13.9	14.9	15.8	16.7	17.6	18.4	19.2	19.9	20.5	21.1	21.6			
	A			22.5	23.5	24.6	25.6	26.5	27.5	28.4	29.2	30.0	30.7	31.3			
100	C			95.2	109.7	125.7	143.4	162.9	184.2	207.7	233.2	261.1	291.4	324.2			
	P			13.3	14.2	15.0	15.8	16.6	17.3	17.9	18.5	19.0	19.4	19.7			
	A			21.9	22.8	23.7	24.6	25.4	26.2	26.9	27.6	28.1	28.6	29.0			
90	C			105.3	120.9	138.1	157.0	177.8	200.6	225.5	252.7	282.2	314.3	348.9			
	P			12.7	13.5	14.2	14.8	15.4	16.0	16.5	16.9	17.2	17.5	17.6			
	A			21.3	22.0	22.8	23.5	24.2	24.8	25.3	25.8	26.2	26.5	26.6			
BLV300BM6D	4GE-30Y			30	130	C	74.7	87.2	101.2	116.7	134.0	153.1	174.3	197.6	223.2	251.3	282.0
						P	17.1	18.4	19.7	20.9	22.2	23.4	24.5	25.6	26.6	27.5	28.4
						A	27.9	29.3	30.7	32.2	33.6	35.0	36.4	37.7	39.0	40.2	41.3
		120	C		86.6	100.6	116.0	133.1	152.1	173.0	196.1	221.4	249.1	279.4	312.4		
			P		16.6	17.8	19.0	20.1	21.2	22.3	23.3	24.3	25.1	25.9	26.6		
			A		27.4	28.7	30.0	31.2	32.5	33.8	35.0	36.1	37.2	38.1	39.0		
		110	C	98.4	113.7	130.6	149.3	169.9	192.6	217.5	244.8	274.6	307.0	342.3			
			P	16.0	17.1	18.2	19.2	20.2	21.1	22.0	22.8	23.5	24.1	24.6			
			A	26.8	27.9	29.1	30.2	31.3	32.4	33.4	34.3	35.2	35.9	36.6			
		100	C	110.1	126.6	144.9	165.1	187.3	211.7	238.5	267.7	299.5	334.1	371.6			
			P	15.3	16.3	17.2	18.1	19.0	19.8	20.5	21.1	21.7	22.1	22.5			
			A	26.1	27.1	28.1	29.0	30.0	30.8	31.7	32.4	33.0	33.6	34.0			
		90	C	121.4	139.2	158.9	180.6	204.4	230.4	259.0	290.1	323.9	360.6	400.3			
			P	14.6	15.4	16.2	17.0	17.7	18.3	18.9	19.3	19.7	20.0	20.2			
			A	25.3	26.1	27.0	27.8	28.5	29.2	29.8	30.4	30.8	31.1	31.3			

Modelo	Compresor	H.P	TSC (°F)	TSE °F C=Capacidad kBtu's/h P=Potencia kW A= Amps.											
				-5	0	5	10	15	20	25	30	35	40	45	
BLV330BM6D	6JE-33Y	33	130	C	76.7	91.0	107.1	125.0	144.9	167.0	191.5	218.5	248.2	280.7	316.3
				P	17.8	19.3	20.8	22.3	23.8	25.2	26.5	27.8	29.0	30.1	31.2
				A	31.1	32.6	34.2	35.7	37.3	38.9	40.5	42.0	43.4	44.8	46.1
			120	C	90.3	106.0	123.5	143.0	164.7	188.6	214.9	243.9	275.7	310.4	348.2
				P	17.5	18.9	20.3	21.7	23.0	24.2	25.4	26.5	27.6	28.5	29.4
				A	30.8	32.2	33.6	35.0	36.4	37.8	39.2	40.5	41.7	42.8	43.9
		110	C	103.8	121.0	140.0	161.0	184.3	210.0	238.2	269.1	302.9	339.8	379.8	
			P	17.1	18.4	19.6	20.8	22.0	23.1	24.1	25.0	25.9	26.7	27.3	
			A	30.4	31.6	32.9	34.1	35.4	36.6	37.7	38.8	39.7	40.6	41.4	
			100	C	117.3	135.8	156.3	178.9	203.8	231.2	261.2	294.1	329.9	368.8	411.0
				P	16.6	17.7	18.8	19.9	20.8	21.8	22.6	23.4	24.0	24.6	25.0
				A	29.9	30.9	32.0	33.1	34.1	35.1	36.0	36.9	37.6	38.3	38.8
90	C	130.7	150.5	172.4	196.5	223.0	252.1	284.0	318.7	356.5	397.5	441.8			
	P	15.9	16.9	17.8	18.7	19.5	20.2	20.9	21.5	21.9	22.3	22.5			
	A	29.2	30.1	31.0	31.9	32.8	33.5	34.2	34.8	35.3	35.7	35.9			
	130	C	94.3	110.7	129.0	149.3	171.8	196.8	224.4	254.7	288.0	324.5	364.3		
		P	21.8	23.6	25.4	27.1	28.8	30.4	32.0	33.5	35.0	36.3	37.5		
		A	35.3	37.2	39.2	41.2	43.2	45.1	47.1	48.9	50.7	52.4	54.0		
BLV350BM6D	6HE-35Y	35	130	C	109.8	127.8	147.8	170.0	194.6	221.7	251.5	284.3	320.1	359.2	401.8
				P	21.3	22.9	24.5	26.1	27.6	29.1	30.5	31.8	33.0	34.1	35.1
				A	34.7	36.5	38.2	40.0	41.8	43.5	45.2	46.8	48.3	49.7	51.0
			120	C	125.0	144.6	166.4	190.5	217.0	246.2	278.3	313.4	351.8	393.5	438.9
				P	20.6	22.1	23.5	24.9	26.3	27.6	28.8	29.9	30.9	31.8	32.5
				A	34.0	35.5	37.1	38.7	40.2	41.7	43.1	44.5	45.7	46.8	47.7
		110	C	140.0	161.3	184.8	210.7	239.2	270.5	304.8	342.3	383.1	427.5	475.6	
			P	19.8	21.1	22.4	23.6	24.8	25.9	26.8	27.7	28.5	29.1	29.7	
			A	33.1	34.5	35.9	37.2	38.5	39.7	40.9	41.9	42.8	43.6	44.2	
			100	C	154.9	177.7	202.9	230.6	261.1	294.5	331.0	370.8	414.1	461.1	511.9
				P	18.9	20.0	21.1	22.1	23.1	24.0	24.7	25.4	25.9	26.3	26.5
				A	32.1	33.3	34.5	35.6	36.6	37.6	38.5	39.2	39.8	40.3	40.6
BLV400BM6D	6GE-40Y	40	130	C	109.7	128.1	148.6	171.2	196.3	223.9	254.4	287.9	324.7	364.9	408.7
				P	25.5	27.5	29.4	31.3	33.2	35.0	36.7	38.4	39.9	41.3	42.7
				A	43.7	45.7	47.7	49.8	51.8	53.8	55.7	57.6	59.4	61.0	62.6
			120	C	127.3	147.7	170.1	195.0	222.4	252.6	285.8	322.2	362.0	405.4	452.7
				P	24.8	26.7	28.4	30.2	31.9	33.5	35.0	36.4	37.8	39.0	40.1
				A	43.0	44.8	46.7	48.5	50.3	52.1	53.8	55.4	56.9	58.3	59.5
		110	C	144.5	166.7	191.2	218.2	248.0	280.8	316.7	356.0	398.8	445.5	496.1	
			P	24.0	25.7	27.3	28.8	30.3	31.7	33.1	34.3	35.4	36.3	37.2	
			A	42.2	43.8	45.5	47.1	48.7	50.2	51.7	53.0	54.2	55.3	56.2	
			100	C	161.3	185.3	211.9	241.1	273.3	308.6	347.2	389.4	435.3	485.2	539.2
				P	23.1	24.6	26.0	27.3	28.6	29.8	30.9	31.9	32.7	33.4	34.0
				A	41.2	42.7	44.1	45.5	46.9	48.1	49.3	50.4	51.3	52.1	52.7
90	C	177.9	203.8	232.3	263.8	298.3	336.2	377.6	422.6	471.6	524.7	582.2			
	P	22.0	23.3	24.5	25.6	26.7	27.6	28.5	29.2	29.8	30.2	30.5			
	A	40.2	41.4	42.6	43.8	44.9	45.9	46.8	47.6	48.2	48.6	48.9			
	130	C	135.4	157.9	182.7	210.1	240.3	273.5	310.1	350.2	394.1	442.2	494.5		
		P	30.6	32.9	35.3	37.5	39.7	41.9	44.0	46.0	47.8	49.6	51.1		
		A	60.6	63.1	65.6	68.0	70.3	72.5	74.6	76.5	78.3	79.9	81.3		
BLV500BM6D	6FE-50Y	50	120	C	156.7	181.5	208.8	238.9	272.0	308.4	348.4	392.2	440.0	492.1	548.8
				P	29.9	32.0	34.1	36.2	38.2	40.2	42.0	43.7	45.3	46.8	48.1
				A	59.8	62.1	64.4	66.6	68.8	70.8	72.7	74.4	76.0	77.4	78.5
			110	C	177.5	204.5	234.3	267.1	303.1	342.7	386.1	433.5	485.1	541.3	602.3
				P	28.9	30.9	32.8	34.7	36.4	38.1	39.7	41.2	42.5	43.6	44.6
				A	58.8	60.9	63.0	65.0	66.9	68.7	70.4	71.9	73.2	74.3	75.3
		100	C	197.7	227.0	259.2	294.7	333.6	376.4	423.1	474.1	529.5	589.8	655.0	
			P	27.8	29.6	31.3	32.9	34.4	35.8	37.1	38.3	39.3	40.2	40.8	
			A	57.5	59.5	61.3	63.1	64.8	66.3	67.7	69.0	70.0	70.9	71.5	
			90	C	217.4	248.9	283.5	321.7	363.5	409.4	459.4	513.9	573.2	637.4	706.9
				P	26.6	28.1	29.5	30.9	32.2	33.3	34.3	35.2	35.9	36.4	36.7
				A	56.1	57.8	59.4	60.9	62.3	63.6	64.7	65.7	66.4	67.0	67.3

Modelo	Compresor	H.P	TSC (°F)	TSE °F C=Capacidad kBtu's/h P=Potencia kW A= Amps.													
				-5	0	5	10	15	20	25	30	35	40	45			
BLV150BM6C	4PES-15Y	15	130	C	36.5	43.6	51.6	60.6	70.6	81.9	94.5	108.5	124.0	141.0	159.7		
				P	8.4	9.3	10.2	11.0	11.8	12.6	13.3	14.0	14.6	15.2	15.7		
				A	29.1	30.9	32.6	34.4	36.2	37.9	39.6	41.2	42.7	44.1	45.4		
			120	C	43.3	51.2	60.0	70.0	81.1	93.4	107.1	122.3	139.0	157.4	177.5		
				P	8.4	9.2	10.0	10.8	11.5	12.1	12.7	13.3	13.8	14.3	14.7		
				A	29.2	30.7	32.3	33.9	35.4	36.9	38.3	39.6	40.9	42.0	43.0		
		110	C	50.2	58.9	68.6	79.5	91.6	105.0	119.9	136.2	154.1	173.8	195.3			
			P	8.4	9.1	9.8	10.4	11.0	11.6	12.1	12.5	12.9	13.3	13.5			
			A	29.0	30.3	31.7	33.1	34.4	35.6	36.8	37.9	38.8	39.6	40.3			
		100	C	57.3	66.8	77.4	89.2	102.2	116.7	132.7	150.2	169.4	190.3	213.1			
			P	8.2	8.8	9.4	9.9	10.4	10.9	11.3	11.7	11.9	12.2	12.3			
			A	28.6	29.8	31.0	32.1	33.2	34.2	35.1	35.9	36.5	37.0	37.4			
		90	C	64.4	74.7	86.2	98.9	113.0	128.5	145.5	164.2	184.7	206.9	231.1			
			P	7.9	8.4	8.9	9.4	9.8	10.1	10.4	10.6	10.8	10.9	10.9			
			A	28.1	29.1	30.0	30.9	31.8	32.5	33.2	33.7	34.0	34.2	34.2			
		BLV200BM6C	4NES-20Y	20	130	C	46.6	55.0	64.3	74.9	86.8	100.0	114.7	131.0	149.1	169.0	190.8
						P	10.3	11.3	12.3	13.2	14.1	14.9	15.8	16.5	17.2	17.9	18.4
						A	33.6	35.6	37.6	39.6	41.7	43.6	45.5	47.4	49.1	50.7	52.2
120	C				54.4	63.6	74.0	85.6	98.6	113.1	129.1	146.8	166.2	187.6	211.0		
	P				10.2	11.1	12.0	12.8	13.6	14.4	15.0	15.7	16.3	16.8	17.2		
	A				33.5	35.2	37.0	38.8	40.5	42.2	43.8	45.3	46.7	48.0	49.1		
110	C			62.2	72.4	83.8	96.5	110.6	126.2	143.5	162.5	183.4	206.3	231.2			
	P			10.0	10.8	11.6	12.3	13.0	13.6	14.2	14.7	15.2	15.5	15.8			
	A			33.1	34.6	36.2	37.7	39.2	40.6	41.9	43.1	44.2	45.1	45.8			
100	C			70.1	81.2	93.6	107.3	122.6	139.5	158.0	178.4	200.7	225.1	251.6			
	P			9.8	10.5	11.1	11.7	12.3	12.8	13.3	13.6	14.0	14.2	14.3			
	A			32.5	33.8	35.1	36.4	37.6	38.7	39.8	40.6	41.4	41.9	42.3			
90	C			78.1	90.1	103.5	118.3	134.7	152.8	172.6	194.3	218.1	243.9	272.0			
	P			9.4	10.0	10.5	11.0	11.5	11.9	12.2	12.4	12.6	12.7	12.7			
	A			31.7	32.9	33.9	35.0	35.9	36.7	37.5	38.0	38.4	38.6	38.6			
BLV220BM6C	4JE-22Y			22	130	C	52.1	61.7	72.5	84.4	97.7	112.4	128.7	146.7	166.4	188.0	211.7
						P	12.0	13.0	14.1	15.1	16.1	17.0	17.9	18.8	19.6	20.4	21.1
						A	37.1	39.4	41.7	44.0	46.3	48.6	50.9	53.1	55.2	57.2	59.1
		120	C		61.3	71.9	83.7	96.7	111.2	127.2	144.8	164.2	185.4	208.6	233.8		
			P		11.8	12.7	13.7	14.6	15.5	16.3	17.1	17.9	18.6	19.2	19.8		
			A		36.6	38.7	40.8	42.8	44.9	46.9	48.9	50.8	52.6	54.2	55.7		
		110	C	70.4	82.0	94.8	109.0	124.6	141.9	160.8	181.6	204.3	228.9	255.8			
			P	11.5	12.3	13.2	14.0	14.8	15.5	16.2	16.8	17.4	17.9	18.4			
			A	36.0	37.8	39.7	41.5	43.3	45.0	46.7	48.2	49.6	50.9	52.0			
		100	C	79.5	92.0	105.8	121.1	137.9	156.4	176.6	198.8	222.9	249.1	277.5			
			P	11.1	11.9	12.6	13.3	14.0	14.6	15.2	15.7	16.1	16.5	16.8			
			A	35.2	36.7	38.3	39.9	41.4	42.8	44.2	45.4	46.5	47.4	48.1			
		90	C	88.5	101.9	116.8	133.1	151.0	170.7	192.2	215.7	241.2	268.9	298.9			
			P	10.6	11.3	11.9	12.5	13.1	13.5	14.0	14.4	14.7	14.9	15.1			
			A	34.2	35.5	36.9	38.1	39.4	40.5	41.5	42.4	43.1	43.6	44.0			
		BLV250BM6C	4HE-25Y	25	130	C	64.1	75.2	87.6	101.3	116.6	133.5	152.2	172.8	195.5	220.3	247.4
						P	14.8	15.9	17.1	18.2	19.3	20.3	21.4	22.3	23.2	24.1	24.8
						A	46.9	49.4	52.0	54.5	57.1	59.6	62.0	64.4	66.6	68.8	70.7
120	C				74.6	86.8	100.4	115.5	132.2	150.7	171.0	193.3	217.7	244.4	273.4		
	P				14.4	15.4	16.5	17.5	18.5	19.4	20.3	21.2	21.9	22.6	23.3		
	A				46.1	48.3	50.6	52.9	55.2	57.4	59.5	61.5	63.4	65.2	66.8		
110	C			85.0	98.4	113.2	129.6	147.7	167.6	189.5	213.4	239.6	268.1	299.0			
	P			13.9	14.9	15.8	16.7	17.6	18.4	19.2	19.9	20.5	21.1	21.6			
	A			45.1	47.1	49.1	51.1	53.1	55.0	56.8	58.4	60.0	61.3	62.5			
100	C			95.2	109.7	125.7	143.4	162.9	184.2	207.7	233.2	261.1	291.4	324.2			
	P			13.3	14.2	15.0	15.8	16.6	17.3	17.9	18.5	19.0	19.4	19.7			
	A			43.9	45.7	47.4	49.1	50.8	52.4	53.8	55.1	56.3	57.2	58.0			
90	C			105.3	120.9	138.1	157.0	177.8	200.6	225.5	252.7	282.2	314.3	348.9			
	P			12.7	13.5	14.2	14.8	15.4	16.0	16.5	16.9	17.2	17.5	17.6			
	A			42.6	44.1	45.6	47.0	48.3	49.5	50.6	51.6	52.3	52.9	53.3			
BLV300BM6C	4GE-30Y			30	130	C	74.7	87.2	101.2	116.7	134.0	153.1	174.3	197.6	223.2	251.3	282.0
						P	17.1	18.4	19.7	20.9	22.2	23.4	24.5	25.6	26.6	27.5	28.4
						A	55.8	58.6	61.5	64.4	67.2	70.1	72.8	75.5	78.0	80.4	82.6
		120	C		86.6	100.6	116.0	133.1	152.1	173.0	196.1	221.4	249.1	279.4	312.4		
			P		16.6	17.8	19.0	20.1	21.2	22.3	23.3	24.3	25.1	25.9	26.6		
			A		54.8	57.3	59.9	62.5	65.0	67.5	69.9	72.2	74.3	76.3	78.0		
		110	C	98.4	113.7	130.6	149.3	169.9	192.6	217.5	244.8	274.6	307.0	342.3			
			P	16.0	17.1	18.2	19.2	20.2	21.1	22.0	22.8	23.5	24.1	24.6			
			A	53.6	55.8	58.1	60.4	62.6	64.7	66.7	68.6	70.3	71.9	73.2			
		100	C	110.1	126.6	144.9	165.1	187.3	211.7	238.5	267.7	299.5	334.1	371.6			
			P	15.3	16.3	17.2	18.1	19.0	19.8	20.5	21.1	21.7	22.1	22.5			
			A	52.2	54.1	56.1	58.1	59.9	61.7	63.3	64.8	66.1	67.2	68.0			
		90	C	121.4	139.2	158.9	180.6	204.4	230.4	259.0	290.1	323.9	360.6	400.3			
			P	14.6	15.4	16.2	17.0	17.7	18.3	18.9	19.3	19.7	20.0	20.2			
			A	50.6	52.3	54.0	55.6	57.1	58.4	59.7	60.7	61.6	62.2	62.6			

Modelo	Compresor	H.P	TSC (°F)	TSE °F C=Capacidad kBTu's/h P=Potencia kW A= Amps.														
				-5	0	5	10	15	20	25	30	35	40	45				
BLV30BM6C	6JE-33Y	33	130	C	76.7	91.0	107.1	125.0	144.9	167.0	191.5	218.5	248.2	280.7	316.3			
				P	17.8	19.3	20.8	22.3	23.8	25.2	26.5	27.8	29.0	30.1	31.2			
				A	62.1	65.2	68.3	71.5	74.7	77.8	80.9	84.0	86.9	89.6	92.2			
			120	C	90.3	106.0	123.5	143.0	164.7	188.6	214.9	243.9	275.7	310.4	348.2			
				P	17.5	18.9	20.3	21.7	23.0	24.2	25.4	26.5	27.6	28.5	29.4			
				A	61.6	64.4	67.2	70.0	72.9	75.6	78.3	80.9	83.4	85.7	87.7			
			110	C	103.8	121.0	140.0	161.0	184.3	210.0	238.2	269.1	302.9	339.8	379.8			
				P	17.1	18.4	19.6	20.8	22.0	23.1	24.1	25.0	25.9	26.7	27.3			
				A	60.8	63.3	65.8	68.3	70.7	73.1	75.4	77.5	79.5	81.3	82.8			
			100	C	117.3	135.8	156.3	178.9	203.8	231.2	261.2	294.1	329.9	368.8	411.0			
				P	16.6	17.7	18.8	19.9	20.8	21.8	22.6	23.4	24.0	24.6	25.0			
				A	59.7	61.9	64.1	66.2	68.3	70.2	72.1	73.8	75.2	76.5	77.5			
			90	C	130.7	150.5	172.4	196.5	223.0	252.1	284.0	318.7	356.5	397.5	441.8			
				P	15.9	16.9	17.8	18.7	19.5	20.2	20.9	21.5	21.9	22.3	22.5			
				A	58.4	60.3	62.1	63.8	65.5	67.1	68.5	69.7	70.7	71.4	71.9			
			BLV350BM6C	6HE-35Y	35	130	C	94.3	110.7	129.0	149.3	171.8	196.8	224.4	254.7	288.0	324.5	364.3
							P	21.8	23.6	25.4	27.1	28.8	30.4	32.0	33.5	35.0	36.3	37.5
							A	70.5	74.4	78.4	82.4	86.3	90.3	94.1	97.9	101.5	104.9	108.0
120	C	109.8				127.8	147.8	170.0	194.6	221.7	251.5	284.3	320.1	359.2	401.8			
	P	21.3				22.9	24.5	26.1	27.6	29.1	30.5	31.8	33.0	34.1	35.1			
	A	69.4				72.9	76.5	80.1	83.6	87.1	90.4	93.6	96.7	99.4	102.0			
110	C	125.0				144.6	166.4	190.5	217.0	246.2	278.3	313.4	351.8	393.5	438.9			
	P	20.6				22.1	23.5	24.9	26.3	27.6	28.8	29.9	30.9	31.8	32.5			
	A	67.9				71.1	74.3	77.4	80.5	83.4	86.3	88.9	91.4	93.6	95.5			
100	C	140.0				161.3	184.8	210.7	239.2	270.5	304.8	342.3	383.1	427.5	475.6			
	P	19.8				21.1	22.4	23.6	24.8	25.9	26.8	27.7	28.5	29.1	29.7			
	A	66.2				69.0	71.7	74.4	77.0	79.5	81.8	83.9	85.7	87.3	88.5			
90	C	154.9				177.7	202.9	230.6	261.1	294.5	331.0	370.8	414.1	461.1	511.9			
	P	18.9				20.0	21.1	22.1	23.1	24.0	24.7	25.4	25.9	26.3	26.5			
	A	64.3				66.6	68.9	71.1	73.2	75.2	76.9	78.4	79.6	80.5	81.1			
BLV400BM6C	6GE-40Y	40				130	C	109.7	128.1	148.6	171.2	196.3	223.9	254.4	287.9	324.7	364.9	408.7
							P	25.5	27.5	29.4	31.3	33.2	35.0	36.7	38.4	39.9	41.3	42.7
							A	87.3	91.4	95.4	99.5	103.6	107.6	111.5	115.2	118.7	122.1	125.1
			120	C	127.3	147.7	170.1	195.0	222.4	252.6	285.8	322.2	362.0	405.4	452.7			
				P	24.8	26.7	28.4	30.2	31.9	33.5	35.0	36.4	37.8	39.0	40.1			
				A	86.0	89.7	93.4	97.1	100.7	104.2	107.6	110.8	113.9	116.6	119.1			
			110	C	144.5	166.7	191.2	218.2	248.0	280.8	316.7	356.0	398.8	445.5	496.1			
				P	24.0	25.7	27.3	28.8	30.3	31.7	33.1	34.3	35.4	36.3	37.2			
				A	84.4	87.7	91.0	94.2	97.4	100.5	103.3	106.0	108.5	110.6	112.5			
			100	C	161.3	185.3	211.9	241.1	273.3	308.6	347.2	389.4	435.3	485.2	539.2			
				P	23.1	24.6	26.0	27.3	28.6	29.8	30.9	31.9	32.7	33.4	34.0			
				A	82.5	85.4	88.2	91.0	93.7	96.3	98.6	100.8	102.6	104.2	105.4			
			90	C	177.9	203.8	232.3	263.8	298.3	336.2	377.6	422.6	471.6	524.7	582.2			
				P	22.0	23.3	24.5	25.6	26.7	27.6	28.5	29.2	29.8	30.2	30.5			
				A	80.3	82.8	85.2	87.5	89.7	91.8	93.6	95.1	96.4	97.3	97.8			
			BLV500BM6C	6FE-50Y	50	130	C	135.4	157.9	182.7	210.1	240.3	273.5	310.1	350.2	394.1	442.2	494.5
							P	30.6	32.9	35.3	37.5	39.7	41.9	44.0	46.0	47.8	49.6	51.1
							A	121.2	126.2	131.1	135.9	140.6	145.0	149.2	153.1	156.7	159.9	162.7
120	C	156.7				181.5	208.8	238.9	272.0	308.4	348.4	392.2	440.0	492.1	548.8			
	P	29.9				32.0	34.1	36.2	38.2	40.2	42.0	43.7	45.3	46.8	48.1			
	A	119.6				124.3	128.9	133.3	137.5	141.6	145.4	148.8	152.0	154.7	157.1			
110	C	177.5				204.5	234.3	267.1	303.1	342.7	386.1	433.5	485.1	541.3	602.3			
	P	28.9				30.9	32.8	34.7	36.4	38.1	39.7	41.2	42.5	43.6	44.6			
	A	117.6				121.9	126.0	130.0	133.9	137.5	140.8	143.8	146.4	148.7	150.5			
100	C	197.7				227.0	259.2	294.7	333.6	376.4	423.1	474.1	529.5	589.8	655.0			
	P	27.8				29.6	31.3	32.9	34.4	35.8	37.1	38.3	39.3	40.2	40.8			
	A	115.1				118.9	122.7	126.2	129.6	132.7	135.5	137.9	140.1	141.8	143.0			
90	C	217.4				248.9	283.5	321.7	363.5	409.4	459.4	513.9	573.2	637.4	706.9			
	P	26.6				28.1	29.5	30.9	32.2	33.3	34.3	35.2	35.9	36.4	36.7			
	A	112.2				115.5	118.8	121.8	124.6	127.2	129.4	131.3	132.8	133.9	134.6			

Modelo	Compresor	H.P	TSC (°F)	TSE °F C=Capacidad kBtu's/h P=Potencia kW A= Amps.													
				-45	-40	-35	-30	-25	-20	-15	-10	-5	0	5			
BLV150BL6D	4JE-15Y	15	130	C	6.3	10.5	15.1	20.1	25.7	32.0	39.0	46.8	55.6	65.5	76.4		
				P	4.2	5.1	6.0	7.0	8.0	9.0	10.1	11.1	12.2	13.2	14.3		
				A	11.9	12.4	13.0	13.8	14.6	15.5	16.5	17.6	18.7	19.9	21.1		
			120	C	9.8	14.5	19.6	25.2	31.5	38.4	46.2	54.9	64.6	75.4	87.4		
				P	4.5	5.3	6.2	7.1	8.0	9.0	10.0	11.0	11.9	12.9	13.9		
				A	12.1	12.6	13.2	13.9	14.7	15.6	16.5	17.5	18.5	19.5	20.6		
		110	C	13.5	18.6	24.2	30.4	37.3	45.0	53.5	63.0	73.6	85.3	98.3			
			P	4.7	5.5	6.3	7.2	8.1	8.9	9.8	10.7	11.6	12.5	13.4			
			A	12.3	12.8	13.4	14.0	14.7	15.5	16.3	17.2	18.1	19.1	20.0			
		100	C	17.2	22.8	28.9	35.7	43.2	51.5	60.8	71.1	82.5	95.2	109.2			
			P	4.9	5.6	6.4	7.2	8.0	8.8	9.6	10.4	11.2	12.0	12.8			
			A	12.5	12.9	13.4	14.0	14.7	15.4	16.1	16.9	17.7	18.5	19.3			
		90	C	21.0	27.0	33.7	41.0	49.1	58.1	68.1	79.1	91.4	105.0	119.9			
			P	5.1	5.7	6.4	7.2	7.9	8.6	9.3	10.1	10.8	11.4	12.1			
			A	12.6	13.0	13.4	14.0	14.6	15.2	15.8	16.5	17.2	17.9	18.6			
		BLV180BL6D	4HE-18Y	18	130	C	9.8	14.7	20.0	25.9	32.3	39.5	47.6	56.6	66.7	78.0	90.6
						P	6.0	6.9	7.9	9.0	10.2	11.3	12.5	13.7	14.9	16.2	17.4
						A	13.0	13.7	14.5	15.5	16.6	17.8	19.1	20.4	21.9	23.3	24.8
120	C				13.6	19.1	25.0	31.5	38.8	46.8	55.8	65.8	77.0	89.4	103.3		
	P				6.1	7.0	8.0	9.0	10.1	11.2	12.3	13.4	14.5	15.7	16.8		
	A				13.1	13.8	14.6	15.5	16.5	17.7	18.8	20.1	21.4	22.7	24.0		
110	C			17.6	23.6	30.2	37.4	45.3	54.2	64.1	75.1	87.3	100.8	115.8			
	P			6.2	7.1	8.0	8.9	9.9	11.0	12.0	13.0	14.0	15.1	16.1			
	A			13.3	13.9	14.6	15.5	16.4	17.4	18.5	19.6	20.8	22.0	23.2			
100	C			21.8	28.3	35.4	43.2	51.9	61.6	72.3	84.3	97.5	112.1	128.3			
	P			6.3	7.1	7.9	8.8	9.8	10.7	11.6	12.6	13.5	14.4	15.3			
	A			13.4	13.9	14.6	15.4	16.2	17.2	18.1	19.1	20.1	21.2	22.2			
90	C			26.0	32.9	40.6	49.1	58.5	68.9	80.5	93.3	107.5	123.2	140.5			
	P			6.3	7.1	7.9	8.7	9.5	10.4	11.2	12.0	12.8	13.6	14.4			
	A			13.4	13.9	14.6	15.3	16.0	16.8	17.7	18.5	19.4	20.3	21.1			
BLV230BL6D	4GE-23Y			23	130	C	14.5	20.1	26.2	32.8	40.2	48.4	57.5	67.8	79.2	92.0	106.3
						P	7.8	8.9	10.0	11.2	12.5	13.8	15.2	16.6	18.0	19.5	20.9
						A	14.4	15.3	16.4	17.7	19.1	20.6	22.2	23.9	25.6	27.4	29.3
		120	C		18.5	24.8	31.6	39.1	47.3	56.5	66.7	78.2	90.9	105.1	120.8		
			P		7.8	8.8	9.9	11.1	12.3	13.5	14.8	16.1	17.4	18.7	20.0		
			A		14.5	15.3	16.4	17.5	18.8	20.2	21.7	23.2	24.8	26.5	28.1		
		110	C	22.8	29.7	37.2	45.4	54.6	64.7	76.0	88.6	102.5	118.0	135.1			
			P	7.8	8.7	9.8	10.9	12.0	13.1	14.3	15.5	16.7	17.9	19.1			
			A	14.5	15.3	16.2	17.3	18.5	19.8	21.1	22.5	24.0	25.4	26.9			
		100	C	27.2	34.7	42.9	51.9	61.8	72.9	85.2	98.9	114.0	130.8	149.2			
			P	7.8	8.7	9.6	10.6	11.7	12.7	13.8	14.9	15.9	17.0	18.0			
			A	14.5	15.2	16.1	17.1	18.2	19.3	20.5	21.8	23.0	24.3	25.6			
		90	C	31.7	39.7	48.5	58.3	69.0	81.0	94.3	109.0	125.3	143.2	163.0			
			P	7.7	8.6	9.4	10.4	11.3	12.2	13.2	14.2	15.1	16.0	16.9			
			A	14.5	15.1	15.9	16.8	17.8	18.8	19.8	20.9	22.0	23.1	24.2			
		BLV280BL6D	4FE-28Y	28	130	C	12.5	20.3	28.6	37.4	46.9	57.2	68.6	81.1	95.0	110.3	127.2
						P	9.3	10.6	11.9	13.3	14.8	16.4	17.9	19.5	21.2	22.8	24.4
						A	20.6	21.6	22.8	24.1	25.5	27.1	28.8	30.6	32.4	34.4	36.3
120	C				19.2	27.5	36.3	45.8	56.1	67.5	79.9	93.7	108.9	125.7	144.2		
	P				9.3	10.5	11.8	13.1	14.5	16.0	17.5	19.0	20.5	22.0	23.4		
	A				20.7	21.6	22.7	23.9	25.3	26.7	28.3	30.0	31.6	33.4	35.1		
110	C			25.8	34.5	43.9	54.1	65.3	77.5	91.1	106.1	122.6	140.8	161.0			
	P			9.2	10.4	11.6	12.9	14.2	15.6	16.9	18.3	19.7	21.0	22.4			
	A			20.7	21.6	22.6	23.7	25.0	26.3	27.7	29.2	30.8	32.3	33.9			
100	C			32.2	41.3	51.3	62.2	74.1	87.4	102.0	118.1	136.0	155.7	177.4			
	P			9.2	10.3	11.4	12.6	13.8	15.1	16.3	17.6	18.8	20.0	21.2			
	A			20.7	21.5	22.4	23.5	24.6	25.8	27.1	28.4	29.8	31.1	32.5			
90	C			38.4	48.0	58.5	70.0	82.8	96.9	112.6	129.9	149.0	170.2	193.4			
	P			9.2	10.2	11.2	12.3	13.4	14.5	15.7	16.8	17.8	18.9	19.9			
	A			20.7	21.4	22.2	23.2	24.2	25.3	26.4	27.5	28.7	29.9	31.0			

Modelo	Compresor	H.P	TSC (°F)	TSE °F C=Capacidad kBtu's/h P=Potencia kW A= Amps.														
				-45	-40	-35	-30	-25	-20	-15	-10	-5	0	5				
BLV340BL6D	6GE-34Y	34	130	C	20.1	29.4	39.2	49.7	61.2	73.8	87.7	103.2	120.3	139.2	160.2			
				P	10.8	12.4	14.1	15.9	17.8	19.8	21.9	24.0	26.2	28.3	30.5			
				A	21.7	23.1	24.7	26.6	28.7	30.9	33.3	35.9	38.5	41.2	43.9			
			120	C	28.3	38.1	48.7	60.2	72.7	86.6	101.8	118.8	137.5	158.3	181.3			
				P	10.9	12.4	14.1	15.8	17.6	19.5	21.4	23.4	25.4	27.4	29.4			
				A	21.9	23.2	24.8	26.5	28.5	30.6	32.8	35.2	37.6	40.0	42.5			
			110	C	35.9	46.4	57.7	70.1	83.8	98.8	115.4	133.9	154.3	176.9	201.8			
				P	11.0	12.5	14.0	15.6	17.3	19.1	20.9	22.7	24.5	26.3	28.1			
				A	22.0	23.3	24.7	26.4	28.2	30.1	32.2	34.3	36.4	38.6	40.8			
			100	C	43.2	54.3	66.4	79.7	94.4	110.6	128.6	148.6	170.7	195.0	221.9			
				P	11.1	12.4	13.9	15.4	17.0	18.6	20.2	21.8	23.5	25.1	26.6			
				A	22.1	23.3	24.6	26.1	27.8	29.5	31.4	33.3	35.2	37.1	39.0			
			90	C	50.3	62.0	74.8	89.0	104.8	122.2	141.6	163.0	186.8	213.0	241.8			
				P	11.1	12.4	13.7	15.1	16.5	18.0	19.4	20.9	22.3	23.7	25.0			
				A	22.1	23.2	24.4	25.8	27.3	28.8	30.4	32.1	33.8	35.4	37.0			
			BLV440BL6D	6FE-44Y	44	130	C	18.8	30.5	42.8	56.0	70.3	85.8	102.9	121.7	142.5	165.4	190.8
							P	14.6	16.4	18.4	20.4	22.6	24.8	27.2	29.5	31.9	34.4	36.8
							A	33.6	35.1	36.7	38.6	40.7	43.0	45.4	47.9	50.5	53.1	55.8
120	C	28.8				41.2	54.4	68.7	84.2	101.2	119.9	140.6	163.4	188.5	216.3			
	P	14.5				16.3	18.2	20.1	22.2	24.3	26.5	28.7	30.9	33.2	35.4			
	A	33.6				35.0	36.6	38.4	40.3	42.5	44.7	47.0	49.4	51.8	54.3			
110	C	38.7				51.7	65.8	81.1	97.9	116.3	136.6	159.1	183.9	211.3	241.4			
	P	14.5				16.1	17.9	19.8	21.7	23.7	25.7	27.8	29.8	31.8	33.8			
	A	33.6				34.9	36.4	38.1	39.9	41.8	43.9	46.0	48.2	50.3	52.5			
100	C	48.3				62.0	76.9	93.2	111.2	131.0	153.0	177.2	204.0	233.5	266.0			
	P	14.4				15.9	17.6	19.3	21.1	23.0	24.8	26.7	28.5	30.3	32.1			
	A	33.6				34.8	36.1	37.7	39.3	41.1	42.9	44.8	46.8	48.7	50.6			
90	C	57.6				72.0	87.7	105.0	124.1	145.3	168.8	194.8	223.5	255.2	290.1			
	P	14.3				15.7	17.3	18.9	20.5	22.1	23.8	25.5	27.1	28.6	30.1			
	A	33.5				34.6	35.8	37.2	38.7	40.3	41.9	43.6	45.3	46.9	48.5			

MODELO BLV

COMPRESOR BITZER

R-449A | 460V

Modelo	Compresor	H.P	TSC (°F)	TSE °F C=Capacidad kBTu's/h P=Potencia kW A= Amps.													
				-45	-40	-35	-30	-25	-20	-15	-10	-5	0	5			
BLV150BL6C	4JE-15Y	15	130	C	6.3	10.5	15.1	20.1	25.7	32.0	39.0	46.8	55.6	65.5	76.4		
				P	4.2	5.1	6.0	7.0	8.0	9.0	10.1	11.1	12.2	13.2	14.3		
				A	23.8	24.8	26.1	27.6	29.2	31.1	33.1	35.2	37.4	39.7	42.1		
			120	C	9.8	14.5	19.6	25.2	31.5	38.4	46.2	54.9	64.6	75.4	87.4		
				P	4.5	5.3	6.2	7.1	8.0	9.0	10.0	11.0	11.9	12.9	13.9		
				A	24.3	25.3	26.5	27.9	29.4	31.1	33.0	34.9	36.9	39.0	41.2		
		110	C	13.5	18.6	24.2	30.4	37.3	45.0	53.5	63.0	73.6	85.3	98.3			
			P	4.7	5.5	6.3	7.2	8.1	8.9	9.8	10.7	11.6	12.5	13.4			
			A	24.7	25.6	26.7	28.0	29.4	31.0	32.7	34.4	36.3	38.1	40.0			
		100	C	17.2	22.8	28.9	35.7	43.2	51.5	60.8	71.1	82.5	95.2	109.2			
			P	4.9	5.6	6.4	7.2	8.0	8.8	9.6	10.4	11.2	12.0	12.8			
			A	25.0	25.8	26.8	28.0	29.3	30.8	32.3	33.8	35.4	37.1	38.7			
		90	C	21.0	27.0	33.7	41.0	49.1	58.1	68.1	79.1	91.4	105.0	119.9			
			P	5.1	5.7	6.4	7.2	7.9	8.6	9.3	10.1	10.8	11.4	12.1			
			A	25.2	26.0	26.9	28.0	29.1	30.4	31.7	33.1	34.4	35.8	37.2			
		BLV180BL6C	4HE-18Y	18	130	C	9.8	14.7	20.0	25.9	32.3	39.5	47.6	56.6	66.7	78.0	90.6
						P	6.0	6.9	7.9	9.0	10.2	11.3	12.5	13.7	14.9	16.2	17.4
						A	25.9	27.4	29.1	31.0	33.2	35.6	38.2	40.9	43.7	46.6	49.6
120	C				13.6	19.1	25.0	31.5	38.8	46.8	55.8	65.8	77.0	89.4	103.3		
	P				6.1	7.0	8.0	9.0	10.1	11.2	12.3	13.4	14.5	15.7	16.8		
	A				26.3	27.6	29.2	31.1	33.1	35.3	37.7	40.2	42.7	45.4	48.1		
110	C			17.6	23.6	30.2	37.4	45.3	54.2	64.1	75.1	87.3	100.8	115.8			
	P			6.2	7.1	8.0	8.9	9.9	11.0	12.0	13.0	14.0	15.1	16.1			
	A			26.5	27.8	29.3	31.0	32.9	34.9	37.0	39.3	41.6	44.0	46.3			
100	C			21.8	28.3	35.4	43.2	51.9	61.6	72.3	84.3	97.5	112.1	128.3			
	P			6.3	7.1	7.9	8.8	9.8	10.7	11.6	12.6	13.5	14.4	15.3			
	A			26.7	27.9	29.2	30.8	32.5	34.3	36.2	38.2	40.3	42.4	44.4			
90	C			26.0	32.9	40.6	49.1	58.5	68.9	80.5	93.3	107.5	123.2	140.5			
	P			6.3	7.1	7.9	8.7	9.5	10.4	11.2	12.0	12.8	13.6	14.4			
	A			26.8	27.9	29.1	30.5	32.0	33.6	35.3	37.1	38.8	40.6	42.3			
BLV230BL6C	4GE-23Y			23	130	C	14.5	20.1	26.2	32.8	40.2	48.4	57.5	67.8	79.2	92.0	106.3
						P	7.8	8.9	10.0	11.2	12.5	13.8	15.2	16.6	18.0	19.5	20.9
						A	28.8	30.7	32.9	35.4	38.1	41.1	44.3	47.7	51.2	54.9	58.6
		120	C		18.5	24.8	31.6	39.1	47.3	56.5	66.7	78.2	90.9	105.1	120.8		
			P		7.8	8.8	9.9	11.1	12.3	13.5	14.8	16.1	17.4	18.7	20.0		
			A		28.9	30.7	32.7	35.1	37.6	40.4	43.4	46.5	49.7	53.0	56.3		
		110	C	22.8	29.7	37.2	45.4	54.6	64.7	76.0	88.6	102.5	118.0	135.1			
			P	7.8	8.7	9.8	10.9	12.0	13.1	14.3	15.5	16.7	17.9	19.1			
			A	29.0	30.6	32.5	34.6	37.0	39.6	42.3	45.1	48.0	50.9	53.8			
		100	C	27.2	34.7	42.9	51.9	61.8	72.9	85.2	98.9	114.0	130.8	149.2			
			P	7.8	8.7	9.6	10.6	11.7	12.7	13.8	14.9	15.9	17.0	18.0			
			A	29.0	30.4	32.2	34.2	36.3	38.6	41.0	43.5	46.1	48.6	51.2			
		90	C	31.7	39.7	48.5	58.3	69.0	81.0	94.3	109.0	125.3	143.2	163.0			
			P	7.7	8.6	9.4	10.4	11.3	12.2	13.2	14.2	15.1	16.0	16.9			
			A	28.9	30.3	31.8	33.6	35.5	37.6	39.7	41.9	44.0	46.2	48.3			
		BLV280BL6C	4FE-28Y	28	130	C	12.5	20.3	28.6	37.4	46.9	57.2	68.6	81.1	95.0	110.3	127.2
						P	9.3	10.6	11.9	13.3	14.8	16.4	17.9	19.5	21.2	22.8	24.4
						A	41.3	43.2	45.5	48.1	51.1	54.2	57.6	61.2	64.9	68.7	72.6
120	C				19.2	27.5	36.3	45.8	56.1	67.5	79.9	93.7	108.9	125.7	144.2		
	P				9.3	10.5	11.8	13.1	14.5	16.0	17.5	19.0	20.5	22.0	23.4		
	A				41.4	43.2	45.4	47.8	50.6	53.5	56.6	59.9	63.3	66.8	70.3		
110	C			25.8	34.5	43.9	54.1	65.3	77.5	91.1	106.1	122.6	140.8	161.0			
	P			9.2	10.4	11.6	12.9	14.2	15.6	16.9	18.3	19.7	21.0	22.4			
	A			41.4	43.1	45.1	47.4	49.9	52.6	55.5	58.5	61.5	64.6	67.7			
100	C			32.2	41.3	51.3	62.2	74.1	87.4	102.0	118.1	136.0	155.7	177.4			
	P			9.2	10.3	11.4	12.6	13.8	15.1	16.3	17.6	18.8	20.0	21.2			
	A			41.4	43.0	44.8	46.9	49.2	51.6	54.2	56.8	59.5	62.3	64.9			
90	C			38.4	48.0	58.5	70.0	82.8	96.9	112.6	129.9	149.0	170.2	193.4			
	P			9.2	10.2	11.2	12.3	13.4	14.5	15.7	16.8	17.8	18.9	19.9			
	A			41.4	42.8	44.5	46.3	48.4	50.5	52.8	55.1	57.4	59.7	62.0			

Modelo	Compresor	H.P	TSC (°F)	TSE °F C=Capacidad kBtu's/h P=Potencia kW A= Amps.														
				-45	-40	-35	-30	-25	-20	-15	-10	-5	0	5				
BLV340BL6C	6GE-34Y	34	130	C	20.1	29.4	39.2	49.7	61.2	73.8	87.7	103.2	120.3	139.2	160.2			
				P	10.8	12.4	14.1	15.9	17.8	19.8	21.9	24.0	26.2	28.3	30.5			
				A	43.3	46.1	49.5	53.2	57.4	61.9	66.7	71.7	77.0	82.3	87.8			
			120	C	28.3	38.1	48.7	60.2	72.7	86.6	101.8	118.8	137.5	158.3	181.3			
				P	10.9	12.4	14.1	15.8	17.6	19.5	21.4	23.4	25.4	27.4	29.4			
				A	43.7	46.4	49.5	53.1	57.0	61.2	65.6	70.3	75.1	80.0	85.0			
			110	C	35.9	46.4	57.7	70.1	83.8	98.8	115.4	133.9	154.3	176.9	201.8			
				P	11.0	12.5	14.0	15.6	17.3	19.1	20.9	22.7	24.5	26.3	28.1			
				A	44.0	46.5	49.5	52.8	56.4	60.2	64.3	68.6	72.9	77.3	81.7			
			100	C	43.2	54.3	66.4	79.7	94.4	110.6	128.6	148.6	170.7	195.0	221.9			
				P	11.1	12.4	13.9	15.4	17.0	18.6	20.2	21.8	23.5	25.1	26.6			
				A	44.2	46.5	49.2	52.2	55.5	59.0	62.7	66.5	70.4	74.2	78.1			
			90	C	50.3	62.0	74.8	89.0	104.8	122.2	141.6	163.0	186.8	213.0	241.8			
				P	11.1	12.4	13.7	15.1	16.5	18.0	19.4	20.9	22.3	23.7	25.0			
				A	44.3	46.4	48.8	51.6	54.5	57.6	60.9	64.2	67.5	70.9	74.1			
			BLV440BL6C	6FE-44Y	44	130	C	18.8	30.5	42.8	56.0	70.3	85.8	102.9	121.7	142.5	165.4	190.8
							P	14.6	16.4	18.4	20.4	22.6	24.8	27.2	29.5	31.9	34.4	36.8
							A	67.3	70.1	73.5	77.3	81.4	85.9	90.7	95.7	100.9	106.3	111.7
120	C	28.8				41.2	54.4	68.7	84.2	101.2	119.9	140.6	163.4	188.5	216.3			
	P	14.5				16.3	18.2	20.1	22.2	24.3	26.5	28.7	30.9	33.2	35.4			
	A	67.3				70.0	73.2	76.8	80.7	84.9	89.4	94.0	98.8	103.6	108.5			
110	C	38.7				51.7	65.8	81.1	97.9	116.3	136.6	159.1	183.9	211.3	241.4			
	P	14.5				16.1	17.9	19.8	21.7	23.7	25.7	27.8	29.8	31.8	33.8			
	A	67.2				69.8	72.8	76.1	79.8	83.7	87.7	92.0	96.3	100.7	105.1			
100	C	48.3				62.0	76.9	93.2	111.2	131.0	153.0	177.2	204.0	233.5	266.0			
	P	14.4				15.9	17.6	19.3	21.1	23.0	24.8	26.7	28.5	30.3	32.1			
	A	67.1				69.5	72.3	75.3	78.7	82.2	85.9	89.7	93.6	97.4	101.2			
90	C	57.6				72.0	87.7	105.0	124.1	145.3	168.8	194.8	223.5	255.2	290.1			
	P	14.3				15.7	17.3	18.9	20.5	22.1	23.8	25.5	27.1	28.6	30.1			
	A	67.0				69.2	71.7	74.5	77.4	80.6	83.9	87.2	90.5	93.8	97.0			

MODELO BLV

COMPRESOR BITZER

R-449A | 230V

Modelo	Compresor	H.P	TSC (°F)	TSE °F C=Capacidad kBtu's/h P=Potencia kW A= Amps.													
				-5	0	5	10	15	20	25	30	35	40	45			
BLV150BM6D	4PES-15Y	15	130	C	35.7	42.2	49.6	58.1	67.5	78.2	90.0	103.2	117.8	133.8	151.5		
				P	9.7	10.6	11.5	12.4	13.2	14.1	14.9	15.7	16.4	17.1	17.8		
				A	15.9	16.8	17.8	18.7	19.7	20.7	21.7	22.7	23.7	24.6	25.5		
			120	C	43.7	51.3	59.9	69.4	80.2	92.1	105.3	119.9	136.0	153.6	172.9		
				P	9.6	10.4	11.2	12.0	12.8	13.5	14.2	14.9	15.6	16.1	16.7		
				A	15.7	16.6	17.4	18.3	19.2	20.1	20.9	21.8	22.6	23.3	24.0		
			110	C	52.0	60.6	70.2	80.9	92.9	106.1	120.6	136.7	154.2	173.4	194.3		
				P	9.4	10.1	10.9	11.6	12.2	12.9	13.5	14.1	14.6	15.1	15.5		
				A	15.5	16.3	17.1	17.8	18.6	19.3	20.1	20.7	21.4	22.0	22.5		
		100	C	60.4	70.0	80.7	92.5	105.6	120.1	136.0	153.5	172.5	193.2	215.7			
			P	9.2	9.8	10.5	11.1	11.6	12.2	12.7	13.1	13.5	13.9	14.1			
			A	15.3	15.9	16.6	17.3	17.9	18.5	19.1	19.6	20.1	20.5	20.9			
		90	C	69.0	79.5	91.3	104.2	118.5	134.3	151.5	170.3	190.8	213.0	237.1			
			P	8.9	9.4	10.0	10.5	11.0	11.4	11.8	12.1	12.4	12.6	12.7			
			A	15.0	15.5	16.1	16.7	17.2	17.7	18.1	18.5	18.8	19.0	19.1			
		BLV200BM6D	4NES-20Y	20	130	C	44.8	52.6	61.4	71.3	82.4	94.8	108.7	124.1	141.1	159.9	180.4
						P	12.2	13.1	14.1	15.1	16.1	17.0	17.9	18.8	19.6	20.4	21.2
						A	18.7	19.8	20.9	22.0	23.2	24.3	25.4	26.6	27.6	28.7	29.7
120	C				54.3	63.2	73.2	84.5	97.0	111.0	126.4	143.5	162.2	182.7	205.2		
	P				11.9	12.8	13.6	14.5	15.4	16.2	17.0	17.8	18.5	19.1	19.7		
	A				18.4	19.4	20.3	21.3	22.3	23.3	24.3	25.3	26.2	27.0	27.8		
110	C				63.8	73.9	85.2	97.7	111.6	127.1	144.1	162.7	183.2	205.5	229.8		
	P				11.5	12.3	13.1	13.9	14.7	15.4	16.1	16.7	17.3	17.8	18.2		
	A				18.0	18.9	19.7	20.6	21.5	22.3	23.1	23.9	24.6	25.3	25.9		
100	C			73.5	84.7	97.2	111.0	126.3	143.2	161.7	182.0	204.1	228.2	254.4			
	P			11.1	11.8	12.5	13.2	13.9	14.5	15.0	15.5	15.9	16.3	16.6			
	A			17.6	18.3	19.1	19.8	20.6	21.3	21.9	22.5	23.0	23.5	23.8			
90	C			83.3	95.6	109.3	124.4	141.1	159.4	179.4	201.3	225.1	250.9	278.9			
	P			10.6	11.3	11.9	12.5	13.0	13.5	13.9	14.2	14.5	14.7	14.8			
	A			17.1	17.8	18.4	19.0	19.6	20.1	20.6	21.0	21.4	21.6	21.8			
BLV220BM6D	4JE-22Y			22	130	C	50.5	59.3	69.2	80.3	92.7	106.5	121.8	138.7	157.2	177.6	199.8
						P	13.4	14.5	15.6	16.7	17.7	18.8	19.8	20.8	21.7	22.6	23.5
						A	20.1	21.3	22.6	23.9	25.2	26.5	27.8	29.1	30.4	31.6	32.7
		120	C		61.4	71.5	82.8	95.3	109.2	124.6	141.6	160.2	180.6	202.8	227.0		
			P		13.2	14.2	15.2	16.2	17.1	18.0	18.9	19.8	20.6	21.3	22.0		
			A		19.9	21.0	22.1	23.3	24.4	25.6	26.7	27.8	28.8	29.8	30.8		
		110	C		72.3	83.7	96.3	110.2	125.6	142.5	161.1	181.4	203.6	227.7	253.8		
			P		12.9	13.8	14.7	15.6	16.4	17.2	17.9	18.6	19.2	19.8	20.3		
			A		19.5	20.5	21.5	22.5	23.5	24.5	25.4	26.3	27.1	27.9	28.6		
		100	C	83.3	95.9	109.7	125.0	141.8	160.3	180.4	202.4	226.3	252.2	280.3			
			P	12.6	13.3	14.1	14.8	15.5	16.1	16.7	17.3	17.8	18.2	18.6			
			A	19.1	20.0	20.8	21.7	22.5	23.3	24.0	24.7	25.3	25.9	26.3			
		90	C	94.3	108.0	123.1	139.7	157.9	177.8	199.5	223.1	248.7	276.4	306.2			
			P	12.0	12.7	13.3	13.9	14.5	15.0	15.5	15.8	16.2	16.4	16.6			
			A	18.5	19.3	20.0	20.7	21.3	21.9	22.5	22.9	23.3	23.7	23.9			
		BLV250BM6D	4HE-25Y	25	130	C	61.4	71.6	83.0	95.8	110.1	126.0	143.6	163.0	184.3	207.7	233.3
						P	16.2	17.5	18.7	19.9	21.1	22.3	23.4	24.6	25.6	26.6	27.6
						A	25.0	26.4	27.8	29.3	30.7	32.2	33.6	35.0	36.4	37.7	39.0
120	C				74.1	85.8	98.8	113.3	129.4	147.1	166.7	188.1	211.6	237.3	265.2		
	P				15.9	17.1	18.2	19.3	20.4	21.4	22.4	23.4	24.3	25.1	25.9		
	A				24.7	25.9	27.2	28.5	29.8	31.1	32.3	33.5	34.6	35.7	36.8		
110	C				86.7	99.9	114.5	130.6	148.4	168.0	189.4	212.9	238.5	266.3	296.5		
	P				15.5	16.5	17.5	18.5	19.5	20.4	21.2	22.0	22.8	23.4	24.1		
	A				24.2	25.4	26.5	27.6	28.7	29.8	30.8	31.8	32.8	33.6	34.4		
100	C			99.3	113.9	130.0	147.7	167.2	188.5	211.8	237.3	264.9	294.9	327.3			
	P			15.0	15.9	16.8	17.6	18.4	19.2	19.9	20.5	21.1	21.6	22.0			
	A			23.6	24.6	25.6	26.6	27.5	28.4	29.2	30.0	30.7	31.3	31.9			
90	C			111.8	127.7	145.3	164.5	185.6	208.7	233.8	261.1	290.8	322.8	357.4			
	P			14.4	15.1	15.9	16.6	17.2	17.8	18.4	18.9	19.3	19.6	19.8			
	A			23.0	23.8	24.6	25.4	26.2	26.9	27.5	28.0	28.5	28.9	29.2			
BLV300BM6D	4GE-30Y			30	130	C	71.1	82.7	95.6	110.1	126.3	144.2	164.1	186.1	210.3	236.8	265.7
						P	18.8	20.2	21.6	23.0	24.4	25.7	27.0	28.3	29.5	30.7	31.8
						A	29.8	31.4	33.0	34.6	36.2	37.9	39.5	41.1	42.6	44.1	45.6
		120	C		85.7	99.0	113.9	130.3	148.6	168.7	191.0	215.4	242.1	271.2	302.9		
			P		18.4	19.7	21.0	22.3	23.5	24.7	25.9	27.0	28.0	29.0	29.9		
			A		29.4	30.8	32.3	33.7	35.2	36.6	38.1	39.4	40.8	42.0	43.2		
		110	C		100.3	115.3	131.9	150.3	170.6	192.9	217.3	244.1	273.3	305.0	339.4		
			P		18.0	19.1	20.3	21.4	22.5	23.5	24.5	25.5	26.3	27.2	27.9		
			A		28.8	30.1	31.4	32.7	34.0	35.2	36.5	37.6	38.7	39.7	40.6		
		100	C	114.7	131.3	149.7	169.9	192.1	216.5	243.2	272.2	303.8	338.0	375.1			
			P	17.3	18.4	19.4	20.4	21.3	22.2	23.0	23.8	24.5	25.1	25.6			
			A	28.1	29.3	30.4	31.5	32.6	33.7	34.7	35.6	36.4	37.2	37.8			
		90	C	128.9	147.1	167.1	189.1	213.3	239.7	268.4	299.7	333.6	370.3	409.9			
			P	16.6	17.5	18.4	19.2	20.0	20.7	21.3	21.9	22.4	22.8	23.2			
			A	27.3	28.3	29.3	30.2	31.1	31.9	32.7	33.4	34.0	34.5	34.8			

Modelo	Compresor	H.P	TSC (°F)	TSE °F C=Capacidad kBTu's/h P=Potencia kW A= Amps.														
				-5	0	5	10	15	20	25	30	35	40	45				
BLV330BM6D	6JE-33Y	33	130	C	74.5	87.7	102.5	119.2	137.8	158.5	181.5	206.8	234.7	265.3	298.8			
				P	19.8	21.4	23.0	24.5	26.0	27.5	28.9	30.2	31.4	32.6	33.6			
				A	33.1	34.8	36.5	38.2	39.9	41.6	43.2	44.8	46.4	47.8	49.2			
			120	C	90.6	105.7	122.5	141.2	162.0	185.0	210.3	238.1	268.6	301.9	338.2			
				P	19.6	21.0	22.5	23.8	25.2	26.4	27.6	28.8	29.8	30.7	31.5			
				A	32.8	34.3	35.8	37.4	38.9	40.3	41.8	43.1	44.4	45.6	46.6			
			110	C	106.8	123.6	142.3	163.1	185.9	211.1	238.8	269.1	302.1	338.0	377.0			
				P	19.2	20.5	21.7	22.9	24.1	25.2	26.2	27.1	27.9	28.7	29.3			
				A	32.4	33.7	35.0	36.4	37.7	38.9	40.1	41.2	42.2	43.1	43.8			
			100	C	123.0	141.6	162.1	184.8	209.7	237.0	267.0	299.6	335.1	373.6	415.2			
				P	18.6	19.7	20.8	21.9	22.8	23.7	24.6	25.3	25.9	26.4	26.8			
				A	31.8	32.9	34.1	35.2	36.3	37.3	38.2	39.1	39.8	40.4	40.8			
			90	C	139.2	159.4	181.7	206.3	233.2	262.6	294.7	329.7	367.5	408.6	452.8			
				P	17.8	18.8	19.7	20.6	21.4	22.1	22.7	23.2	23.6	23.9	24.0			
				A	31.0	32.0	33.0	33.9	34.8	35.5	36.2	36.8	37.2	37.5	37.7			
			BLV350BM6D	6HE-35Y	35	130	C	90.4	105.5	122.3	141.2	162.2	185.6	211.5	240.0	271.4	305.7	343.3
							P	24.5	26.4	28.2	29.9	31.7	33.3	34.9	36.5	37.9	39.3	40.5
							A	38.2	40.3	42.4	44.5	46.6	48.7	50.7	52.6	54.5	56.2	57.8
120	C	109.0				126.2	145.4	166.7	190.3	216.3	245.0	276.5	311.0	348.6	389.6			
	P	24.0				25.7	27.3	28.9	30.4	31.9	33.3	34.6	35.8	37.0	38.0			
	A	37.6				39.5	41.4	43.3	45.1	46.9	48.7	50.3	51.9	53.3	54.6			
110	C	127.5				146.8	168.2	191.9	218.0	246.7	278.2	312.6	350.1	390.9	435.1			
	P	23.3				24.8	26.3	27.7	29.0	30.3	31.4	32.5	33.5	34.4	35.2			
	A	36.8				38.5	40.2	41.8	43.4	45.0	46.4	47.8	49.0	50.1	51.1			
100	C	146.0				167.3	190.9	216.8	245.4	276.7	310.8	348.1	388.6	432.5	480.0			
	P	22.4				23.8	25.0	26.2	27.4	28.4	29.4	30.3	31.0	31.7	32.2			
	A	35.8				37.3	38.8	40.2	41.5	42.8	44.0	45.0	46.0	46.8	47.4			
90	C	164.4				187.7	213.3	241.6	272.5	306.3	343.1	383.2	426.6	473.6	524.3			
	P	21.4				22.5	23.6	24.6	25.6	26.4	27.2	27.8	28.3	28.7	29.0			
	A	34.7				36.0	37.2	38.3	39.4	40.4	41.3	42.1	42.7	43.2	43.5			
BLV400BM6D	6GE-40Y	40				130	C	104.4	121.3	140.1	161.0	184.3	210.2	238.8	270.3	304.9	342.8	384.1
							P	28.6	30.7	32.7	34.7	36.7	38.6	40.4	42.2	43.8	45.4	46.9
							A	46.9	49.1	51.3	53.5	55.7	57.8	59.9	61.9	63.9	65.7	67.5
			120	C	125.7	145.0	166.4	190.2	216.5	245.6	277.5	312.5	350.9	392.6	438.0			
				P	28.0	29.9	31.7	33.5	35.3	36.9	38.5	40.1	41.5	42.8	44.0			
				A	46.2	48.2	50.2	52.1	54.1	56.0	57.8	59.6	61.2	62.8	64.2			
			110	C	146.6	168.4	192.4	219.0	248.3	280.4	315.7	354.2	396.2	441.8	491.2			
				P	27.2	28.9	30.5	32.1	33.6	35.1	36.5	37.7	38.9	40.0	41.0			
				A	45.3	47.1	48.9	50.6	52.3	53.9	55.5	57.0	58.3	59.5	60.6			
			100	C	167.5	191.6	218.2	247.5	279.7	314.9	353.4	395.4	441.0	490.4	543.8			
				P	26.1	27.6	29.1	30.5	31.8	33.0	34.2	35.2	36.2	37.0	37.7			
				A	44.2	45.8	47.3	48.9	50.3	51.7	53.0	54.2	55.2	56.1	56.9			
			90	C	188.3	214.7	243.9	275.9	310.9	349.2	390.9	436.2	485.4	538.5	595.8			
				P	25.0	26.3	27.5	28.7	29.8	30.8	31.7	32.6	33.3	33.8	34.3			
				A	43.0	44.4	45.7	47.0	48.2	49.3	50.3	51.2	52.0	52.6	53.0			
			BLV500BM6D	6FE-50Y	50	130	C	128.6	149.1	171.8	197.1	225.2	256.3	290.6	328.4	369.8	415.2	464.6
							P	34.7	37.3	39.9	42.5	45.0	47.4	49.7	52.0	54.1	56.1	58.0
							A	64.9	67.7	70.4	73.0	75.5	77.9	80.1	82.2	84.1	85.8	87.3
120	C	154.5				177.9	204.0	232.8	264.6	299.6	338.1	380.3	426.3	476.5	531.1			
	P	34.2				36.6	38.9	41.2	43.5	45.6	47.7	49.6	51.4	53.1	54.6			
	A	64.4				66.9	69.4	71.8	74.1	76.2	78.2	80.0	81.7	83.1	84.3			
110	C	180.0				206.4	235.7	267.9	303.3	342.2	384.8	431.3	481.9	536.8	596.4			
	P	33.4				35.5	37.6	39.7	41.6	43.5	45.2	46.9	48.4	49.7	50.9			
	A	63.5				65.9	68.1	70.3	72.3	74.2	75.9	77.5	78.9	80.0	81.0			
100	C	205.3				234.6	266.9	302.4	341.4	384.1	430.6	481.3	536.4	596.0	660.5			
	P	32.3				34.2	36.0	37.8	39.5	41.1	42.5	43.8	45.0	46.0	46.8			
	A	62.4				64.5	66.5	68.4	70.1	71.8	73.2	74.5	75.6	76.5	77.1			
90	C	230.2				262.2	297.6	336.3	378.8	425.2	475.6	530.5	589.9	654.1	723.4			
	P	30.9				32.6	34.2	35.7	37.1	38.3	39.5	40.5	41.3	42.0	42.4			
	A	60.9				62.7	64.5	66.1	67.6	69.0	70.2	71.2	72.0	72.5	72.9			

Modelo	Compresor	H.P	TSC (°F)	TSE °F C=Capacidad kBtu's/h P=Potencia kW A= Amps.													
				-5	0	5	10	15	20	25	30	35	40	45			
BLV150BM6C	4PES-15Y	15	130	C	35.7	42.2	49.6	58.1	67.5	78.2	90.0	103.2	117.8	133.8	151.5		
				P	9.7	10.6	11.5	12.4	13.2	14.1	14.9	15.7	16.4	17.1	17.8		
				A	31.7	33.6	35.5	37.5	39.5	41.5	43.5	45.4	47.3	49.2	50.9		
			120	C	43.7	51.3	59.9	69.4	80.2	92.1	105.3	119.9	136.0	153.6	172.9		
				P	9.6	10.4	11.2	12.0	12.8	13.5	14.2	14.9	15.6	16.1	16.7		
				A	31.4	33.1	34.9	36.6	38.4	40.2	41.9	43.5	45.1	46.6	48.0		
		110	C	52.0	60.6	70.2	80.9	92.9	106.1	120.6	136.7	154.2	173.4	194.3			
			P	9.4	10.1	10.9	11.6	12.2	12.9	13.5	14.1	14.6	15.1	15.5			
			A	31.0	32.6	34.1	35.7	37.2	38.7	40.1	41.5	42.8	43.9	45.0			
		100	C	60.4	70.0	80.7	92.5	105.6	120.1	136.0	153.5	172.5	193.2	215.7			
			P	9.2	9.8	10.5	11.1	11.6	12.2	12.7	13.1	13.5	13.9	14.1			
			A	30.5	31.9	33.2	34.5	35.8	37.1	38.2	39.3	40.2	41.1	41.7			
		90	C	69.0	79.5	91.3	104.2	118.5	134.3	151.5	170.3	190.8	213.0	237.1			
			P	8.9	9.4	10.0	10.5	11.0	11.4	11.8	12.1	12.4	12.6	12.7			
			A	29.9	31.1	32.2	33.3	34.3	35.3	36.2	36.9	37.5	38.0	38.3			
		BLV200BM6C	4NES-20Y	20	130	C	44.8	52.6	61.4	71.3	82.4	94.8	108.7	124.1	141.1	159.9	180.4
						P	12.2	13.1	14.1	15.1	16.1	17.0	17.9	18.8	19.6	20.4	21.2
						A	37.5	39.6	41.8	44.1	46.3	48.6	50.9	53.1	55.3	57.3	59.3
120	C				54.3	63.2	73.2	84.5	97.0	111.0	126.4	143.5	162.2	182.7	205.2		
	P				11.9	12.8	13.6	14.5	15.4	16.2	17.0	17.8	18.5	19.1	19.7		
	A				36.8	38.7	40.7	42.7	44.7	46.7	48.6	50.5	52.3	54.0	55.6		
110	C			63.8	73.9	85.2	97.7	111.6	127.1	144.1	162.7	183.2	205.5	229.8			
	P			11.5	12.3	13.1	13.9	14.7	15.4	16.1	16.7	17.3	17.8	18.2			
	A			36.0	37.7	39.5	41.2	43.0	44.6	46.3	47.8	49.3	50.6	51.7			
100	C			73.5	84.7	97.2	111.0	126.3	143.2	161.7	182.0	204.1	228.2	254.4			
	P			11.1	11.8	12.5	13.2	13.9	14.5	15.0	15.5	15.9	16.3	16.6			
	A			35.1	36.6	38.2	39.7	41.1	42.5	43.8	45.0	46.0	46.9	47.7			
90	C			83.3	95.6	109.3	124.4	141.1	159.4	179.4	201.3	225.1	250.9	278.9			
	P			10.6	11.3	11.9	12.5	13.0	13.5	13.9	14.2	14.5	14.7	14.8			
	A			34.2	35.5	36.8	38.0	39.2	40.3	41.2	42.0	42.7	43.2	43.5			
BLV220BM6C	4JE-22Y			22	130	C	50.5	59.3	69.2	80.3	92.7	106.5	121.8	138.7	157.2	177.6	199.8
						P	13.4	14.5	15.6	16.7	17.7	18.8	19.8	20.8	21.7	22.6	23.5
						A	40.2	42.7	45.2	47.8	50.4	53.0	55.6	58.2	60.7	63.1	65.5
		120	C		61.4	71.5	82.8	95.3	109.2	124.6	141.6	160.2	180.6	202.8	227.0		
			P		13.2	14.2	15.2	16.2	17.1	18.0	18.9	19.8	20.6	21.3	22.0		
			A		39.7	42.0	44.3	46.6	48.9	51.1	53.4	55.6	57.7	59.6	61.5		
		110	C	72.3	83.7	96.3	110.2	125.6	142.5	161.1	181.4	203.6	227.7	253.8			
			P	12.9	13.8	14.7	15.6	16.4	17.2	17.9	18.6	19.2	19.8	20.3			
			A	39.1	41.1	43.1	45.1	47.0	49.0	50.8	52.6	54.3	55.8	57.2			
		100	C	83.3	95.9	109.7	125.0	141.8	160.3	180.4	202.4	226.3	252.2	280.3			
			P	12.6	13.3	14.1	14.8	15.5	16.1	16.7	17.3	17.8	18.2	18.6			
			A	38.2	39.9	41.6	43.3	45.0	46.5	48.0	49.4	50.6	51.7	52.6			
		90	C	94.3	108.0	123.1	139.7	157.9	177.8	199.5	223.1	248.7	276.4	306.2			
			P	12.0	12.7	13.3	13.9	14.5	15.0	15.5	15.8	16.2	16.4	16.6			
			A	37.1	38.5	40.0	41.3	42.6	43.8	44.9	45.9	46.7	47.3	47.7			
		BLV250BM6C	4HE-25Y	25	130	C	61.4	71.6	83.0	95.8	110.1	126.0	143.6	163.0	184.3	207.7	233.3
						P	16.2	17.5	18.7	19.9	21.1	22.3	23.4	24.6	25.6	26.6	27.6
						A	50.0	52.8	55.7	58.5	61.4	64.3	67.2	70.0	72.7	75.4	77.9
120	C				74.1	85.8	98.8	113.3	129.4	147.1	166.7	188.1	211.6	237.3	265.2		
	P				15.9	17.1	18.2	19.3	20.4	21.4	22.4	23.4	24.3	25.1	25.9		
	A				49.4	51.9	54.4	57.0	59.6	62.1	64.6	67.0	69.3	71.5	73.6		
110	C			86.7	99.9	114.5	130.6	148.4	168.0	189.4	212.9	238.5	266.3	296.5			
	P			15.5	16.5	17.5	18.5	19.5	20.4	21.2	22.0	22.8	23.4	24.1			
	A			48.5	50.7	53.0	55.2	57.4	59.6	61.7	63.7	65.5	67.3	68.8			
100	C			99.3	113.9	130.0	147.7	167.2	188.5	211.8	237.3	264.9	294.9	327.3			
	P			15.0	15.9	16.8	17.6	18.4	19.2	19.9	20.5	21.1	21.6	22.0			
	A			47.3	49.3	51.2	53.1	55.0	56.8	58.5	60.0	61.4	62.7	63.8			
90	C			111.8	127.7	145.3	164.5	185.6	208.7	233.8	261.1	290.8	322.8	357.4			
	P			14.4	15.1	15.9	16.6	17.2	17.8	18.4	18.9	19.3	19.6	19.8			
	A			45.9	47.6	49.2	50.8	52.3	53.7	55.0	56.1	57.0	57.8	58.4			
BLV300BM6C	4GE-30Y			30	130	C	71.1	82.7	95.6	110.1	126.3	144.2	164.1	186.1	210.3	236.8	265.7
						P	18.8	20.2	21.6	23.0	24.4	25.7	27.0	28.3	29.5	30.7	31.8
						A	59.6	62.7	65.9	69.2	72.5	75.7	79.0	82.2	85.3	88.3	91.1
		120	C		85.7	99.0	113.9	130.3	148.6	168.7	191.0	215.4	242.1	271.2	302.9		
			P		18.4	19.7	21.0	22.3	23.5	24.7	25.9	27.0	28.0	29.0	29.9		
			A		58.7	61.6	64.5	67.5	70.4	73.3	76.1	78.9	81.5	84.1	86.4		
		110	C	100.3	115.3	131.9	150.3	170.6	192.9	217.3	244.1	273.3	305.0	339.4			
			P	18.0	19.1	20.3	21.4	22.5	23.5	24.5	25.5	26.3	27.2	27.9			
			A	57.6	60.2	62.8	65.4	68.0	70.5	72.9	75.2	77.4	79.4	81.3			
		100	C	114.7	131.3	149.7	169.9	192.1	216.5	243.2	272.2	303.8	338.0	375.1			
			P	17.3	18.4	19.4	20.4	21.3	22.2	23.0	23.8	24.5	25.1	25.6			
			A	56.3	58.5	60.8	63.1	65.2	67.3	69.3	71.2	72.9	74.4	75.7			
		90	C	128.9	147.1	167.1	189.1	213.3	239.7	268.4	299.7	333.6	370.3	409.9			
			P	16.6	17.5	18.4	19.2	20.0	20.7	21.3	21.9	22.4	22.8	23.2			
			A	54.7	56.6	58.5	60.4	62.2	63.8	65.4	66.7	67.9	68.9	69.7			

Modelo	Compresor	H.P	TSC (°F)	TSE °F C=Capacidad kBTu's/h P=Potencia kW A= Amps.														
				-5	0	5	10	15	20	25	30	35	40	45				
BLV30BM6C	6JE-33Y	33	130	C	74.5	87.7	102.5	119.2	137.8	158.5	181.5	206.8	234.7	265.3	298.8			
				P	19.8	21.4	23.0	24.5	26.0	27.5	28.9	30.2	31.4	32.6	33.6			
				A	66.2	69.5	72.9	76.3	79.8	83.1	86.5	89.7	92.7	95.6	98.3			
			120	C	90.6	105.7	122.5	141.2	162.0	185.0	210.3	238.1	268.6	301.9	338.2			
				P	19.6	21.0	22.5	23.8	25.2	26.4	27.6	28.8	29.8	30.7	31.5			
				A	65.6	68.6	71.7	74.7	77.7	80.7	83.5	86.2	88.8	91.1	93.2			
			110	C	106.8	123.6	142.3	163.1	185.9	211.1	238.8	269.1	302.1	338.0	377.0			
				P	19.2	20.5	21.7	22.9	24.1	25.2	26.2	27.1	27.9	28.7	29.3			
				A	64.7	67.4	70.1	72.7	75.3	77.8	80.2	82.4	84.4	86.2	87.7			
			100	C	123.0	141.6	162.1	184.8	209.7	237.0	267.0	299.6	335.1	373.6	415.2			
				P	18.6	19.7	20.8	21.9	22.8	23.7	24.6	25.3	25.9	26.4	26.8			
				A	63.5	65.9	68.2	70.4	72.6	74.6	76.5	78.2	79.6	80.8	81.7			
			90	C	139.2	159.4	181.7	206.3	233.2	262.6	294.7	329.7	367.5	408.6	452.8			
				P	17.8	18.8	19.7	20.6	21.4	22.1	22.7	23.2	23.6	23.9	24.0			
				A	62.0	64.0	65.9	67.8	69.5	71.1	72.4	73.6	74.4	75.0	75.3			
			BLV350BM6C	6HE-35Y	35	130	C	90.4	105.5	122.3	141.2	162.2	185.6	211.5	240.0	271.4	305.7	343.3
							P	24.5	26.4	28.2	29.9	31.7	33.3	34.9	36.5	37.9	39.3	40.5
							A	76.5	80.6	84.8	89.1	93.2	97.3	101.4	105.2	108.9	112.4	115.6
120	C	109.0				126.2	145.4	166.7	190.3	216.3	245.0	276.5	311.0	348.6	389.6			
	P	24.0				25.7	27.3	28.9	30.4	31.9	33.3	34.6	35.8	37.0	38.0			
	A	75.3				79.0	82.8	86.6	90.3	93.9	97.3	100.6	103.7	106.6	109.2			
110	C	127.5				146.8	168.2	191.9	218.0	246.7	278.2	312.6	350.1	390.9	435.1			
	P	23.3				24.8	26.3	27.7	29.0	30.3	31.4	32.5	33.5	34.4	35.2			
	A	73.7				77.0	80.4	83.6	86.8	89.9	92.8	95.5	98.0	100.3	102.2			
100	C	146.0				167.3	190.9	216.8	245.4	276.7	310.8	348.1	388.6	432.5	480.0			
	P	22.4				23.8	25.0	26.2	27.4	28.4	29.4	30.3	31.0	31.7	32.2			
	A	71.7				74.6	77.5	80.3	83.0	85.6	87.9	90.0	91.9	93.5	94.8			
90	C	164.4				187.7	213.3	241.6	272.5	306.3	343.1	383.2	426.6	473.6	524.3			
	P	21.4				22.5	23.6	24.6	25.6	26.4	27.2	27.8	28.3	28.7	29.0			
	A	69.4				71.9	74.4	76.7	78.9	80.9	82.7	84.2	85.5	86.4	87.0			
BLV400BM6C	6GE-40Y	40				130	C	104.4	121.3	140.1	161.0	184.3	210.2	238.8	270.3	304.9	342.8	384.1
							P	28.6	30.7	32.7	34.7	36.7	38.6	40.4	42.2	43.8	45.4	46.9
							A	93.8	98.1	102.5	106.9	111.3	115.6	119.8	123.9	127.8	131.5	134.9
			120	C	125.7	145.0	166.4	190.2	216.5	245.6	277.5	312.5	350.9	392.6	438.0			
				P	28.0	29.9	31.7	33.5	35.3	36.9	38.5	40.1	41.5	42.8	44.0			
				A	92.4	96.4	100.3	104.3	108.2	112.0	115.6	119.1	122.4	125.5	128.3			
			110	C	146.6	168.4	192.4	219.0	248.3	280.4	315.7	354.2	396.2	441.8	491.2			
				P	27.2	28.9	30.5	32.1	33.6	35.1	36.5	37.7	38.9	40.0	41.0			
				A	90.6	94.2	97.7	101.2	104.6	107.8	111.0	113.9	116.6	119.1	121.3			
			100	C	167.5	191.6	218.2	247.5	279.7	314.9	353.4	395.4	441.0	490.4	543.8			
				P	26.1	27.6	29.1	30.5	31.8	33.0	34.2	35.2	36.2	37.0	37.7			
				A	88.5	91.6	94.7	97.7	100.6	103.4	105.9	108.3	110.4	112.3	113.8			
			90	C	188.3	214.7	243.9	275.9	310.9	349.2	390.9	436.2	485.4	538.5	595.8			
				P	25.0	26.3	27.5	28.7	29.8	30.8	31.7	32.6	33.3	33.8	34.3			
				A	86.1	88.8	91.4	94.0	96.4	98.6	100.6	102.4	104.0	105.2	106.1			
			BLV500BM6C	6FE-50Y	50	130	C	128.6	149.1	171.8	197.1	225.2	256.3	290.6	328.4	369.8	415.2	464.6
							P	34.7	37.3	39.9	42.5	45.0	47.4	49.7	52.0	54.1	56.1	58.0
							A	129.8	135.3	140.7	145.9	151.0	155.7	160.2	164.4	168.2	171.6	174.6
120	C	154.5				177.9	204.0	232.8	264.6	299.6	338.1	380.3	426.3	476.5	531.1			
	P	34.2				36.6	38.9	41.2	43.5	45.6	47.7	49.6	51.4	53.1	54.6			
	A	128.8				133.9	138.8	143.6	148.1	152.4	156.4	160.1	163.4	166.3	168.7			
110	C	180.0				206.4	235.7	267.9	303.3	342.2	384.8	431.3	481.9	536.8	596.4			
	P	33.4				35.5	37.6	39.7	41.6	43.5	45.2	46.9	48.4	49.7	50.9			
	A	127.1				131.7	136.2	140.5	144.6	148.4	151.8	155.0	157.7	160.1	161.9			
100	C	205.3				234.6	266.9	302.4	341.4	384.1	430.6	481.3	536.4	596.0	660.5			
	P	32.3				34.2	36.0	37.8	39.5	41.1	42.5	43.8	45.0	46.0	46.8			
	A	124.8				128.9	132.9	136.7	140.3	143.5	146.5	149.1	151.2	153.0	154.3			
90	C	230.2				262.2	297.6	336.3	378.8	425.2	475.6	530.5	589.9	654.1	723.4			
	P	30.9				32.6	34.2	35.7	37.1	38.3	39.5	40.5	41.3	42.0	42.4			
	A	121.8				125.5	129.0	132.2	135.2	138.0	140.3	142.3	143.9	145.1	145.8			

Modelo	Compresor	H.P	TSC (°F)	TSE °F C=Capacidad kBTu's/h P=Potencia kW A= Amps.													
				-45	-40	-35	-30	-25	-20	-15	-10	-5	0	5			
BLV150BL6D	4JE-15Y	15	130	C	9.8	13.2	17.0	21.3	26.1	31.7	37.9	45.1	53.1	62.3	72.5		
				P	5.9	6.8	7.8	8.8	9.8	10.9	11.9	13.0	14.1	15.2	16.3		
				A	13.0	13.7	14.5	15.3	16.3	17.4	18.5	19.7	20.9	22.2	23.5		
			120	C	13.3	17.4	22.0	27.1	32.9	39.3	46.6	54.9	64.1	74.4	85.9		
				P	6.2	7.1	8.0	8.9	9.9	10.9	11.9	12.9	13.9	14.9	15.8		
				A	13.3	13.9	14.6	15.5	16.4	17.3	18.4	19.5	20.6	21.7	22.9		
		110	C	17.1	21.9	27.2	33.1	39.8	47.2	55.5	64.8	75.1	86.6	99.3			
			P	6.4	7.2	8.1	9.0	9.9	10.8	11.7	12.6	13.5	14.4	15.3			
			A	13.5	14.1	14.7	15.5	16.3	17.2	18.2	19.1	20.1	21.2	22.2			
		100	C	21.1	26.6	32.7	39.4	46.9	55.2	64.5	74.8	86.2	98.8	112.8			
			P	6.6	7.3	8.1	8.9	9.8	10.6	11.4	12.2	13.0	13.8	14.6			
			A	13.6	14.1	14.8	15.5	16.2	17.0	17.9	18.7	19.6	20.5	21.4			
		90	C	25.4	31.5	38.3	45.7	54.0	63.2	73.5	84.8	97.3	111.0	126.2			
			P	6.6	7.4	8.1	8.8	9.6	10.3	11.1	11.8	12.5	13.1	13.8			
			A	13.6	14.1	14.7	15.4	16.0	16.8	17.5	18.2	19.0	19.7	20.5			
		BLV180BL6D	4HE-18Y	18	130	C	13.1	17.1	21.5	26.5	32.1	38.5	45.7	54.0	63.3	73.7	85.5
						P	7.4	8.5	9.6	10.7	11.9	13.1	14.4	15.7	17.0	18.3	19.6
						A	14.1	15.0	16.0	17.2	18.4	19.8	21.2	22.7	24.3	25.9	27.6
120	C				17.1	21.9	27.3	33.2	39.9	47.4	55.9	65.3	76.0	87.9	101.1		
	P				7.7	8.7	9.7	10.8	11.9	13.1	14.2	15.4	16.6	17.8	19.0		
	A				14.4	15.2	16.2	17.3	18.4	19.7	21.0	22.4	23.8	25.3	26.8		
110	C			21.4	27.1	33.3	40.2	47.9	56.5	66.1	76.8	88.8	102.0	116.8			
	P			7.8	8.8	9.7	10.8	11.8	12.9	13.9	15.0	16.1	17.2	18.2			
	A			14.5	15.3	16.2	17.2	18.3	19.5	20.7	21.9	23.2	24.5	25.8			
100	C			26.1	32.4	39.5	47.3	56.0	65.6	76.4	88.3	101.5	116.2	132.3			
	P			7.9	8.8	9.7	10.7	11.6	12.6	13.6	14.5	15.5	16.5	17.4			
	A			14.6	15.3	16.2	17.1	18.1	19.2	20.2	21.4	22.5	23.6	24.8			
90	C			30.9	38.0	45.8	54.5	64.1	74.8	86.7	99.8	114.2	130.2	147.7			
	P			7.9	8.7	9.6	10.5	11.3	12.2	13.1	14.0	14.8	15.6	16.4			
	A			14.6	15.3	16.1	16.9	17.8	18.7	19.7	20.7	21.6	22.6	23.6			
BLV230BL6D	4GE-23Y			23	130	C	17.2	21.8	26.9	32.6	39.1	46.3	54.6	64.0	74.5	86.5	99.9
						P	9.2	10.4	11.7	13.0	14.4	15.8	17.3	18.8	20.3	21.9	23.4
						A	15.7	16.8	18.2	19.6	21.2	22.9	24.7	26.6	28.5	30.5	32.6
		120	C		21.8	27.3	33.5	40.3	48.0	56.6	66.2	77.1	89.2	102.8	117.9		
			P		9.4	10.5	11.7	12.9	14.3	15.6	17.0	18.4	19.8	21.2	22.6		
			A		15.9	17.0	18.2	19.6	21.1	22.6	24.3	26.0	27.8	29.7	31.5		
		110	C	26.7	33.2	40.3	48.2	57.1	66.9	77.9	90.2	103.9	119.1	135.9			
			P	9.4	10.5	11.6	12.8	14.0	15.3	16.6	17.8	19.1	20.4	21.7			
			A	15.9	17.0	18.1	19.4	20.8	22.3	23.8	25.4	27.0	28.6	30.3			
		100	C	31.8	39.2	47.3	56.3	66.2	77.3	89.6	103.3	118.5	135.2	153.7			
			P	9.4	10.4	11.5	12.6	13.7	14.9	16.0	17.2	18.4	19.5	20.6			
			A	15.9	16.9	18.0	19.2	20.4	21.8	23.2	24.6	26.0	27.5	28.9			
		90	C	37.2	45.4	54.4	64.4	75.4	87.7	101.2	116.3	132.8	151.1	171.2			
			P	9.3	10.3	11.3	12.3	13.4	14.4	15.4	16.5	17.5	18.4	19.4			
			A	15.8	16.8	17.8	18.8	20.0	21.2	22.4	23.6	24.9	26.1	27.3			
		BLV280BL6D	4FE-28Y	28	130	C	18.3	24.4	31.1	38.4	46.4	55.4	65.5	76.7	89.3	103.3	119.0
						P	10.2	11.8	13.5	15.2	16.9	18.7	20.5	22.4	24.2	26.0	27.8
						A	21.3	22.7	24.3	26.0	27.8	29.7	31.8	33.9	36.1	38.3	40.5
120	C				24.8	31.8	39.6	48.0	57.4	67.8	79.4	92.3	106.6	122.6	140.3		
	P				10.7	12.2	13.7	15.3	17.0	18.6	20.3	22.0	23.7	25.3	27.0		
	A				21.8	23.1	24.5	26.1	27.8	29.6	31.5	33.4	35.4	37.4	39.4		
110	C			31.4	39.4	48.1	57.7	68.3	80.1	93.2	107.7	123.8	141.7	161.4			
	P			11.0	12.4	13.8	15.3	16.8	18.4	19.9	21.4	23.0	24.4	25.9			
	A			22.0	23.3	24.6	26.1	27.6	29.3	31.0	32.8	34.5	36.3	38.1			
100	C			38.1	47.0	56.7	67.4	79.3	92.4	107.0	123.1	140.9	160.5	182.2			
	P			11.2	12.5	13.8	15.2	16.5	17.9	19.3	20.7	22.1	23.4	24.7			
	A			22.2	23.3	24.5	25.9	27.3	28.8	30.3	31.9	33.5	35.1	36.6			
90	C			44.9	54.6	65.3	77.0	90.1	104.5	120.5	138.2	157.7	179.2	202.7			
	P			11.2	12.4	13.6	14.9	16.1	17.4	18.6	19.8	21.0	22.2	23.2			
	A			22.2	23.2	24.3	25.5	26.8	28.1	29.5	30.9	32.3	33.6	34.9			

Modelo	Compresor	H.P	TSC (°F)	TSE °F C=Capacidad kBTu's/h P=Potencia kW A= Amps.														
				-45	-40	-35	-30	-25	-20	-15	-10	-5	0	5				
BLV340BL6D	6GE-34Y	34	130	C	26.0	33.3	41.3	50.1	59.9	70.9	83.2	97.1	112.7	130.2	149.7			
				P	14.3	16.2	18.1	20.2	22.3	24.5	26.7	28.9	31.2	33.4	35.7			
				A	24.9	26.9	29.0	31.4	33.8	36.4	39.1	41.9	44.7	47.6	50.5			
			120	C	34.0	42.5	51.8	62.0	73.5	86.2	100.5	116.4	134.2	154.0	176.0			
				P	14.6	16.4	18.2	20.1	22.0	24.0	26.1	28.1	30.2	32.2	34.2			
				A	25.3	27.1	29.1	31.3	33.5	35.9	38.4	40.9	43.5	46.1	48.6			
			110	C	41.9	51.5	62.1	73.8	86.9	101.4	117.5	135.4	155.4	177.5	201.9			
				P	14.7	16.3	18.0	19.8	21.6	23.4	25.3	27.1	29.0	30.8	32.6			
				A	25.4	27.1	28.9	30.9	33.0	35.1	37.4	39.7	42.0	44.3	46.6			
			100	C	49.7	60.5	72.4	85.6	100.2	116.4	134.3	154.3	176.3	200.7	227.6			
				P	14.6	16.2	17.7	19.3	21.0	22.6	24.3	26.0	27.6	29.2	30.8			
				A	25.4	26.9	28.6	30.4	32.3	34.2	36.2	38.2	40.3	42.3	44.3			
			90	C	57.7	69.6	82.8	97.4	113.5	131.4	151.2	173.1	197.2	223.9	253.1			
				P	14.4	15.8	17.3	18.7	20.2	21.7	23.2	24.7	26.1	27.5	28.9			
				A	25.2	26.6	28.1	29.7	31.4	33.1	34.9	36.7	38.4	40.2	41.9			
			BLV440BL6D	6FE-44Y	44	130	C	27.4	36.7	46.6	57.6	69.7	83.1	98.2	115.1	133.9	155.0	178.5
							P	16.3	18.6	21.1	23.6	26.1	28.8	31.4	34.1	36.7	39.3	42.0
							A	34.9	37.0	39.3	41.7	44.3	47.1	49.9	52.8	55.7	58.7	61.7
120	C	37.1				47.8	59.3	72.0	86.1	101.7	119.1	138.4	159.9	183.9	210.4			
	P	16.9				19.2	21.4	23.8	26.2	28.6	31.1	33.5	35.9	38.3	40.7			
	A	35.6				37.5	39.7	42.0	44.4	46.9	49.5	52.2	54.9	57.6	60.3			
110	C	47.1				59.1	72.2	86.6	102.5	120.2	139.8	161.6	185.8	212.5	242.1			
	P	17.4				19.5	21.6	23.8	26.0	28.2	30.5	32.7	34.9	37.1	39.2			
	A	36.0				37.8	39.8	41.9	44.1	46.5	48.8	51.2	53.7	56.1	58.5			
100	C	57.2				70.5	85.0	101.1	118.9	138.6	160.4	184.6	211.3	240.8	273.3			
	P	17.6				19.6	21.5	23.5	25.6	27.6	29.6	31.6	33.6	35.5	37.4			
	A	36.2				37.9	39.7	41.7	43.7	45.8	47.9	50.1	52.2	54.4	56.5			
90	C	67.4				81.9	97.9	115.6	135.1	156.8	180.8	207.3	236.5	268.7	304.1			
	P	17.7				19.5	21.3	23.1	24.9	26.8	28.6	30.3	32.1	33.7	35.3			
	A	36.3				37.8	39.5	41.2	43.0	44.9	46.8	48.7	50.6	52.4	54.2			

Modelo	Compresor	H.P	TSC (°F)	TSE °F C=Capacidad kBTu's/h P=Potencia kW A= Amps.														
				-45	-40	-35	-30	-25	-20	-15	-10	-5	0	5				
BLV150BL6C	4JE-15Y	15	130	C	9.8	13.2	17.0	21.3	26.1	31.7	37.9	45.1	53.1	62.3	72.5			
				P	5.9	6.8	7.8	8.8	9.8	10.9	11.9	13.0	14.1	15.2	16.3			
				A	26.0	27.4	28.9	30.7	32.6	34.7	37.0	39.3	41.8	44.3	47.0			
			120	C	13.3	17.4	22.0	27.1	32.9	39.3	46.6	54.9	64.1	74.4	85.9			
				P	6.2	7.1	8.0	8.9	9.9	10.9	11.9	12.9	13.9	14.9	15.8			
				A	26.6	27.8	29.3	30.9	32.7	34.7	36.8	38.9	41.2	43.5	45.8			
			110	C	17.1	21.9	27.2	33.1	39.8	47.2	55.5	64.8	75.1	86.6	99.3			
				P	6.4	7.2	8.1	9.0	9.9	10.8	11.7	12.6	13.5	14.4	15.3			
				A	26.9	28.1	29.5	31.0	32.7	34.5	36.3	38.3	40.3	42.3	44.4			
			100	C	21.1	26.6	32.7	39.4	46.9	55.2	64.5	74.8	86.2	98.8	112.8			
				P	6.6	7.3	8.1	8.9	9.8	10.6	11.4	12.2	13.0	13.8	14.6			
				A	27.1	28.3	29.5	31.0	32.5	34.1	35.8	37.5	39.2	41.0	42.7			
			90	C	25.4	31.5	38.3	45.7	54.0	63.2	73.5	84.8	97.3	111.0	126.2			
				P	6.6	7.4	8.1	8.8	9.6	10.3	11.1	11.8	12.5	13.1	13.8			
				A	27.2	28.3	29.4	30.7	32.1	33.5	35.0	36.5	38.0	39.5	40.9			
			BLV180BL6C	4HE-18Y	18	130	C	13.1	17.1	21.5	26.5	32.1	38.5	45.7	54.0	63.3	73.7	85.5
							P	7.4	8.5	9.6	10.7	11.9	13.1	14.4	15.7	17.0	18.3	19.6
							A	28.3	30.1	32.1	34.4	36.9	39.6	42.5	45.5	48.6	51.9	55.2
120	C	17.1				21.9	27.3	33.2	39.9	47.4	55.9	65.3	76.0	87.9	101.1			
	P	7.7				8.7	9.7	10.8	11.9	13.1	14.2	15.4	16.6	17.8	19.0			
	A	28.8				30.4	32.4	34.5	36.9	39.4	42.0	44.8	47.7	50.6	53.6			
110	C	21.4				27.1	33.3	40.2	47.9	56.5	66.1	76.8	88.8	102.0	116.8			
	P	7.8				8.8	9.7	10.8	11.8	12.9	13.9	15.0	16.1	17.2	18.2			
	A	29.0				30.6	32.5	34.5	36.6	38.9	41.4	43.9	46.4	49.1	51.7			
100	C	26.1				32.4	39.5	47.3	56.0	65.6	76.4	88.3	101.5	116.2	132.3			
	P	7.9				8.8	9.7	10.7	11.6	12.6	13.6	14.5	15.5	16.5	17.4			
	A	29.2				30.7	32.4	34.2	36.2	38.3	40.5	42.7	45.0	47.3	49.5			
90	C	30.9				38.0	45.8	54.5	64.1	74.8	86.7	99.8	114.2	130.2	147.7			
	P	7.9				8.7	9.6	10.5	11.3	12.2	13.1	14.0	14.8	15.6	16.4			
	A	29.2				30.6	32.1	33.8	35.6	37.5	39.4	41.3	43.3	45.2	47.1			
BLV230BL6C	4GE-23Y	23				130	C	17.2	21.8	26.9	32.6	39.1	46.3	54.6	64.0	74.5	86.5	99.9
							P	9.2	10.4	11.7	13.0	14.4	15.8	17.3	18.8	20.3	21.9	23.4
							A	31.4	33.7	36.3	39.2	42.4	45.8	49.4	53.1	57.1	61.1	65.2
			120	C	21.8	27.3	33.5	40.3	48.0	56.6	66.2	77.1	89.2	102.8	117.9			
				P	9.4	10.5	11.7	12.9	14.3	15.6	17.0	18.4	19.8	21.2	22.6			
				A	31.7	33.9	36.4	39.1	42.1	45.3	48.6	52.1	55.7	59.4	63.1			
			110	C	26.7	33.2	40.3	48.2	57.1	66.9	77.9	90.2	103.9	119.1	135.9			
				P	9.4	10.5	11.6	12.8	14.0	15.3	16.6	17.8	19.1	20.4	21.7			
				A	31.9	33.9	36.3	38.9	41.6	44.5	47.6	50.8	54.0	57.3	60.6			
			100	C	31.8	39.2	47.3	56.3	66.2	77.3	89.6	103.3	118.5	135.2	153.7			
				P	9.4	10.4	11.5	12.6	13.7	14.9	16.0	17.2	18.4	19.5	20.6			
				A	31.8	33.8	36.0	38.4	40.9	43.6	46.3	49.2	52.0	54.9	57.8			
			90	C	37.2	45.4	54.4	64.4	75.4	87.7	101.2	116.3	132.8	151.1	171.2			
				P	9.3	10.3	11.3	12.3	13.4	14.4	15.4	16.5	17.5	18.4	19.4			
				A	31.7	33.5	35.5	37.7	40.0	42.4	44.8	47.3	49.8	52.3	54.7			
			BLV280BL6C	4FE-28Y	28	130	C	18.3	24.4	31.1	38.4	46.4	55.4	65.5	76.7	89.3	103.3	119.0
							P	10.2	11.8	13.5	15.2	16.9	18.7	20.5	22.4	24.2	26.0	27.8
							A	42.6	45.4	48.5	51.9	55.6	59.5	63.6	67.8	72.1	76.6	81.0
120	C	24.8				31.8	39.6	48.0	57.4	67.8	79.4	92.3	106.6	122.6	140.3			
	P	10.7				12.2	13.7	15.3	17.0	18.6	20.3	22.0	23.7	25.3	27.0			
	A	43.5				46.1	49.0	52.2	55.6	59.2	63.0	66.9	70.8	74.8	78.9			
110	C	31.4				39.4	48.1	57.7	68.3	80.1	93.2	107.7	123.8	141.7	161.4			
	P	11.0				12.4	13.8	15.3	16.8	18.4	19.9	21.4	23.0	24.4	25.9			
	A	44.1				46.5	49.2	52.2	55.3	58.6	62.0	65.5	69.1	72.7	76.2			
100	C	38.1				47.0	56.7	67.4	79.3	92.4	107.0	123.1	140.9	160.5	182.2			
	P	11.2				12.5	13.8	15.2	16.5	17.9	19.3	20.7	22.1	23.4	24.7			
	A	44.4				46.6	49.1	51.8	54.6	57.6	60.7	63.8	67.0	70.1	73.2			
90	C	44.9				54.6	65.3	77.0	90.1	104.5	120.5	138.2	157.7	179.2	202.7			
	P	11.2				12.4	13.6	14.9	16.1	17.4	18.6	19.8	21.0	22.2	23.2			
	A	44.4				46.4	48.7	51.1	53.6	56.3	59.0	61.8	64.5	67.2	69.8			

Modelo	Compresor	H.P	TSC (°F)	TSE °F C=Capacidad kBTu's/h P=Potencia kW A= Amps.														
				-45	-40	-35	-30	-25	-20	-15	-10	-5	0	5				
BLV340BL6C	6GE-34Y	34	130	C	26.0	33.3	41.3	50.1	59.9	70.9	83.2	97.1	112.7	130.2	149.7			
				P	14.3	16.2	18.1	20.2	22.3	24.5	26.7	28.9	31.2	33.4	35.7			
				A	49.8	53.8	58.1	62.7	67.7	72.9	78.3	83.8	89.5	95.2	101.0			
			120	C	34.0	42.5	51.8	62.0	73.5	86.2	100.5	116.4	134.2	154.0	176.0			
				P	14.6	16.4	18.2	20.1	22.0	24.0	26.1	28.1	30.2	32.2	34.2			
				A	50.6	54.2	58.2	62.5	67.1	71.8	76.7	81.8	86.9	92.1	97.3			
			110	C	41.9	51.5	62.1	73.8	86.9	101.4	117.5	135.4	155.4	177.5	201.9			
				P	14.7	16.3	18.0	19.8	21.6	23.4	25.3	27.1	29.0	30.8	32.6			
				A	50.9	54.2	57.9	61.8	66.0	70.3	74.7	79.3	83.9	88.5	93.1			
			100	C	49.7	60.5	72.4	85.6	100.2	116.4	134.3	154.3	176.3	200.7	227.6			
				P	14.6	16.2	17.7	19.3	21.0	22.6	24.3	26.0	27.6	29.2	30.8			
				A	50.7	53.8	57.2	60.7	64.5	68.4	72.4	76.5	80.5	84.6	88.6			
			90	C	57.7	69.6	82.8	97.4	113.5	131.4	151.2	173.1	197.2	223.9	253.1			
				P	14.4	15.8	17.3	18.7	20.2	21.7	23.2	24.7	26.1	27.5	28.9			
				A	50.3	53.1	56.1	59.4	62.7	66.2	69.8	73.3	76.9	80.4	83.8			
			BLV440BL6C	6FE-44Y	44	130	C	27.4	36.7	46.6	57.6	69.7	83.1	98.2	115.1	133.9	155.0	178.5
							P	16.3	18.6	21.1	23.6	26.1	28.8	31.4	34.1	36.7	39.3	42.0
							A	69.8	74.0	78.6	83.5	88.7	94.1	99.8	105.6	111.5	117.5	123.5
120	C	37.1				47.8	59.3	72.0	86.1	101.7	119.1	138.4	159.9	183.9	210.4			
	P	16.9				19.2	21.4	23.8	26.2	28.6	31.1	33.5	35.9	38.3	40.7			
	A	71.1				75.1	79.3	83.9	88.7	93.8	99.0	104.3	109.7	115.1	120.6			
110	C	47.1				59.1	72.2	86.6	102.5	120.2	139.8	161.6	185.8	212.5	242.1			
	P	17.4				19.5	21.6	23.8	26.0	28.2	30.5	32.7	34.9	37.1	39.2			
	A	72.0				75.7	79.6	83.9	88.3	92.9	97.7	102.5	107.3	112.2	117.0			
100	C	57.2				70.5	85.0	101.1	118.9	138.6	160.4	184.6	211.3	240.8	273.3			
	P	17.6				19.6	21.5	23.5	25.6	27.6	29.6	31.6	33.6	35.5	37.4			
	A	72.4				75.8	79.5	83.3	87.4	91.6	95.8	100.2	104.5	108.7	112.9			
90	C	67.4				81.9	97.9	115.6	135.1	156.8	180.8	207.3	236.5	268.7	304.1			
	P	17.7				19.5	21.3	23.1	24.9	26.8	28.6	30.3	32.1	33.7	35.3			
	A	72.5				75.6	78.9	82.4	86.0	89.8	93.6	97.4	101.1	104.8	108.3			

Modelo	Compresor	H.P	TSC (°F)		TSE °F C=Capacidad kBtu's/h P=Potencia kW A= Amps.												
					-5	0	5	10	15	20	25	30	35	40	45		
BLV1500M6D	3DS3R17ME-TFD	15	130	C	45.658	55.528	65.921	76.898	88.519	100.847	113.941	127.863	142.674	158.436	175.208		
				P	11.403	12.012	12.655	13.319	13.992	14.658	15.306	15.922	16.493	17.004	17.443		
				A	19.6	20.0	20.6	21.2	21.8	22.6	23.3	24.0	24.8	25.5	26.2		
			120	C	53.057	63.081	73.810	85.307	97.631	110.845	125.010	140.185	156.433	173.814	192.390		
				P	10.761	11.336	11.935	12.544	13.151	13.742	14.304	14.823	15.286	15.680	15.991		
				A	18.5	19.0	19.5	20.1	20.7	21.4	22.1	22.7	23.3	23.9	24.4		
			110	C	60.306	70.532	81.648	93.715	106.793	120.944	136.228	152.707	170.441	189.492	209.921		
				P	10.174	10.708	11.255	11.802	12.337	12.845	13.313	13.728	14.077	14.346	14.522		
				A	17.6	18.1	18.6	19.1	19.7	20.3	20.9	21.4	21.9	22.3	22.6		
		100	C	67.194	77.674	89.227	101.914	115.795	130.933	147.387	165.220	184.491	205.262	227.595			
			P	9.618	10.104	10.593	11.071	11.526	11.944	12.312	12.617	12.844	12.982	13.015			
			A	16.8	17.3	17.8	18.3	18.8	19.3	19.7	20.1	20.4	20.7	20.8			
		90	C	73.513	84.297	96.337	109.694	124.429	140.604	158.279	177.515	198.373	220.915	245.201			
			P	9.072	9.503	9.926	10.329	10.697	11.019	11.279	11.466	11.565	11.564	11.448			
			A	16.1	16.6	17.0	17.4	17.8	18.2	18.5	18.8	18.9	18.9	18.9			
		BLV2000M6D	4DBNR20ME-TSK	20	130	C	61.147	71.883	83.538	96.252	110.165	125.417	142.148	160.499	180.609	202.619	226.668
						P	13.367	14.367	15.372	16.365	17.335	18.266	19.147	19.962	20.699	21.343	21.881
						A	22.5	23.5	24.5	25.6	26.7	27.8	28.8	29.8	30.8	31.7	32.5
120	C				69.838	81.344	93.872	107.562	122.554	138.988	157.003	176.741	198.341	221.944	247.689		
	P				12.973	13.869	14.759	15.632	16.473	17.268	18.003	18.666	19.242	19.718	20.080		
	A				21.8	22.7	23.7	24.6	25.6	26.5	27.4	28.3	29.1	29.8	30.4		
110	C				78.079	90.379	103.803	118.492	134.585	152.223	171.545	192.693	215.805	241.022	268.485		
	P				12.482	13.274	14.053	14.807	15.520	16.180	16.773	17.285	17.703	18.013	18.200		
	A				21.1	21.9	22.8	23.6	24.5	25.3	26.0	26.7	27.3	27.8	28.2		
100	C			85.871	98.986	113.329	129.039	146.256	165.120	185.772	208.351	232.999	259.854	289.057			
	P			11.905	12.595	13.265	13.900	14.489	15.016	15.467	15.831	16.092	16.237	16.252			
	A			20.4	21.1	21.9	22.6	23.3	23.9	24.5	25.0	25.4	25.7	25.9			
90	C			93.212	107.165	122.449	139.202	157.565	177.679	199.683	223.717	249.921	278.436	309.402			
	P			11.252	11.842	12.404	12.924	13.389	13.785	14.098	14.314	14.420	14.402	14.247			
	A			19.7	20.3	21.0	21.5	22.1	22.5	22.9	23.2	23.4	23.5	23.4			
BLV2500M6D	4DHNR22ME-TSK			25	130	C	66.722	78.531	91.367	105.382	120.727	137.553	156.009	176.249	198.421	222.677	249.169
						P	14.891	16.017	17.143	18.255	19.338	20.378	21.358	22.265	23.084	23.799	24.395
						A	25.3	26.4	27.6	28.8	30.0	31.2	32.4	33.6	34.6	35.6	36.6
		120	C		76.278	88.944	102.750	117.846	134.385	152.516	172.391	194.160	217.975	243.986	272.344		
			P		14.457	15.468	16.470	17.450	18.392	19.281	20.103	20.842	21.484	22.014	22.417		
			A		24.4	25.5	26.6	27.7	28.8	29.9	30.9	31.8	32.7	33.5	34.2		
		110	C		85.321	98.869	113.668	129.871	147.627	167.089	188.406	211.731	237.212	265.003	295.253		
			P		13.943	14.839	15.719	16.568	17.369	18.110	18.773	19.346	19.813	20.159	20.369		
			A		23.7	24.7	25.6	26.6	27.6	28.5	29.3	30.1	30.8	31.3	31.8		
		100	C	93.862	108.316	124.133	141.466	160.466	181.283	204.067	228.971	256.144	285.738	317.904			
			P	13.349	14.133	14.891	15.609	16.272	16.864	17.372	17.779	18.072	18.235	18.253			
			A	23.0	23.8	24.7	25.5	26.3	27.0	27.7	28.2	28.7	29.0	29.2			
		90	C	101.912	117.296	134.156	152.645	172.911	195.108	219.384	245.892	274.781	306.204	340.310			
			P	12.676	13.349	13.987	14.576	15.101	15.547	15.899	16.142	16.262	16.243	16.070			
			A	22.3	23.0	23.7	24.4	25.0	25.5	26.0	26.3	26.5	26.6	26.5			
		BLV3000M6D	4DJNR28ME-TSK	30	130	C	61.113	73.948	87.688	102.413	118.204	135.142	153.307	172.779	193.640	215.969	239.847
						P	13.865	15.164	16.440	17.686	18.889	20.042	21.133	22.153	23.093	23.941	24.689
						A	27.9	29.6	31.4	33.1	34.8	36.5	38.0	39.5	40.8	42.0	43.1
120	C				70.853	84.895	99.881	115.893	133.010	151.313	170.883	191.801	214.146	237.999	263.441		
	P				13.764	14.902	16.013	17.086	18.111	19.080	19.980	20.804	21.541	22.181	22.714		
	A				28.1	29.6	31.1	32.5	33.9	35.2	36.5	37.6	38.6	39.5	40.1		
110	C				80.205	95.301	111.382	128.528	146.819	166.335	187.158	209.368	233.046	258.271	285.125		
	P				13.453	14.439	15.391	16.299	17.154	17.945	18.662	19.297	19.838	20.277	20.602		
	A				28.0	29.2	30.4	31.6	32.7	33.7	34.6	35.5	36.2	36.7	37.1		
100	C			89.156	105.155	122.178	140.305	159.618	180.196	202.120	225.470	250.328	276.773	304.887			
	P			12.967	13.808	14.608	15.359	16.049	16.671	17.213	17.665	18.018	18.263	18.388			
	A			27.5	28.5	29.4	30.4	31.2	32.0	32.6	33.2	33.6	33.8	33.9			
90	C			97.694	114.444	132.257	151.214	171.396	192.883	215.756	240.095	265.981	293.493	322.714			
	P			12.339	13.041	13.698	14.298	14.832	15.291	15.665	15.943	16.115	16.173	16.105			
	A			26.8	27.6	28.3	29.0	29.6	30.1	30.5	30.8	30.9	30.9	30.7			

Modelo	Compresor	H.P	TSC (°F)	TSE °F C=Capacidad kBTU's/h P=Potencia kW A= Amps.													
				-5	0	5	10	15	20	25	30	35	40	45			
BLV3500M6D	6D.HNR35ME-TSK	35	130	C	99,267	117,779	138,050	160,004	183,567	208,663	235,216	263,152	292,393	322,865	354,493		
				P	22,071	23,605	25,194	26,815	28,445	30,058	31,631	33,141	34,562	35,872	37,047		
				A	37.0	38.3	39.8	41.6	43.5	45.4	47.5	49.5	51.5	53.3	55.1		
			120	C	112,394	131,408	152,458	175,471	200,370	227,080	255,526	285,631	317,321	350,520	385,153		
				P	21,240	22,599	24,007	25,439	26,871	28,279	29,639	30,928	32,121	33,194	34,124		
				A	35.4	36.6	38.1	39.7	41.4	43.2	45.0	46.8	48.5	50.1	51.4		
			110	C	124,651	144,274	166,211	190,389	216,731	245,162	275,607	307,990	342,236	378,268	416,013		
				P	20,246	21,444	22,682	23,936	25,183	26,399	27,558	28,639	29,616	30,465	31,164		
				A	33.8	35.0	36.3	37.8	39.3	40.9	42.5	44.0	45.4	46.7	47.7		
			100	C	136,256	156,594	179,525	204,975	232,867	263,127	295,678	330,445	367,353	406,326	447,289		
				P	19,127	20,176	21,258	22,347	23,422	24,457	25,429	26,313	27,086	27,725	28,204		
				A	32.3	33.3	34.5	35.8	37.2	38.6	39.9	41.2	42.3	43.2	43.9		
		90	C	147,424	168,585	192,618	219,446	248,995	281,190	315,954	353,212	392,890	434,910	479,199			
			P	17,923	18,835	19,772	20,710	21,625	22,492	23,288	23,989	24,571	25,011	25,283			
			A	30.8	31.7	32.8	33.9	35.1	36.2	37.3	38.3	39.1	39.7	40.0			
		BLV4000M6D	6D.NR40ME-TSN	40	130	C	118,773	140,129	163,793	189,642	217,558	247,419	279,106	312,498	347,475	383,916	421,702
						P	26,909	28,702	30,582	32,518	34,476	36,425	38,333	40,166	41,893	43,482	44,898
						A	45.1	46.6	48.3	50.4	52.6	55.0	57.5	60.0	62.4	64.7	66.8
					120	C	133,569	155,703	180,458	207,713	237,348	269,243	303,277	339,331	377,283	417,014	458,403
						P	25,819	27,412	29,083	30,797	32,524	34,231	35,885	37,455	38,906	40,208	41,329
						A	43.1	44.4	46.1	48.0	50.1	52.3	54.5	56.7	58.8	60.7	62.4
					110	C	147,544	170,558	196,506	225,269	256,726	290,757	327,241	366,059	407,089	450,212	495,307
						P	24,507	25,915	27,389	28,897	30,406	31,883	33,297	34,616	35,806	36,835	37,672
						A	40.9	42.2	43.8	45.6	47.4	49.4	51.3	53.2	54.9	56.5	57.8
100	C				160,937	184,933	212,178	242,551	275,932	312,202	351,238	392,922	437,133	483,750	532,653		
	P				23,038	24,273	25,564	26,878	28,182	29,444	30,631	31,712	32,654	33,424	33,991		
	A				38.8	40.0	41.5	43.0	44.7	46.4	48.1	49.6	51.0	52.1	53.0		
90	C			173,987	199,067	227,711	259,797	295,205	333,815	375,507	420,159	467,653	517,867	570,681			
	P			21,471	22,548	23,669	24,802	25,915	26,975	27,949	28,806	29,513	30,037	30,347			
	A			36.8	37.9	39.2	40.6	42.0	43.5	44.8	46.0	47.0	47.8	48.1			

MODELO BLV

COMPRESOR COPELAND

R-449A | 460V

Modelo	Compresor	H.P	TSC (°F)	TSE °F C=Capacidad kBtu's/h P=Potencia kW A= Amps.													
				-5	0	5	10	15	20	25	30	35	40	45			
BLV1500M6C	3DS3R17ME-TFD	15	130	C	45.658	55.528	65.921	76.898	88.519	100.847	113.941	127.863	142.674	158.436	175.208		
				P	11.403	12.012	12.655	13.319	13.992	14.658	15.306	15.922	16.493	17.004	17.443		
				A	39.1	40.0	41.1	42.3	43.7	45.1	46.6	48.1	49.6	51.0	52.4		
			120	C	53.057	63.081	73.810	85.307	97.631	110.845	125.010	140.185	156.433	173.814	192.390		
				P	10.761	11.336	11.935	12.544	13.151	13.742	14.304	14.823	15.286	15.680	15.991		
				A	37.0	37.9	39.0	40.2	41.5	42.8	44.1	45.4	46.7	47.8	48.9		
			110	C	60.306	70.532	81.648	93.715	106.793	120.944	136.228	152.707	170.441	189.492	209.921		
				P	10.174	10.708	11.255	11.802	12.337	12.845	13.313	13.728	14.077	14.346	14.522		
				A	35.2	36.1	37.2	38.3	39.4	40.6	41.7	42.8	43.8	44.6	45.3		
		100	C	67.194	77.674	89.227	101.914	115.795	130.933	147.387	165.220	184.491	205.262	227.595			
			P	9.618	10.104	10.593	11.071	11.526	11.944	12.312	12.617	12.844	12.982	13.015			
			A	33.6	34.5	35.5	36.5	37.5	38.5	39.4	40.2	40.8	41.3	41.6			
		90	C	73.513	84.297	96.337	109.694	124.429	140.604	158.279	177.515	198.373	220.915	245.201			
			P	9.072	9.503	9.926	10.329	10.697	11.019	11.279	11.466	11.565	11.564	11.448			
			A	32.2	33.1	34.0	34.9	35.7	36.4	37.0	37.5	37.8	37.9	37.7			
		BLV2000M6C	4DBNR20ME-TSK	20	130	C	61.147	71.883	83.538	96.252	110.165	125.417	142.148	160.499	180.609	202.619	226.668
						P	13.367	14.367	15.372	16.365	17.335	18.266	19.147	19.962	20.699	21.343	21.881
						A	45.0	47.0	49.1	51.2	53.4	55.5	57.6	59.6	61.6	63.4	65.0
120	C				69.838	81.344	93.872	107.562	122.554	138.988	157.003	176.741	198.341	221.944	247.689		
	P				12.973	13.869	14.759	15.632	16.473	17.268	18.003	18.666	19.242	19.718	20.080		
	A				43.5	45.4	47.3	49.3	51.2	53.1	54.9	56.6	58.2	59.6	60.9		
110	C				78.079	90.379	103.803	118.492	134.585	152.223	171.545	192.693	215.805	241.022	268.485		
	P				12.482	13.274	14.053	14.807	15.520	16.180	16.773	17.285	17.703	18.013	18.200		
	A				42.1	43.8	45.6	47.3	49.0	50.6	52.1	53.4	54.6	55.7	56.5		
100	C			85.871	98.986	113.329	129.039	146.256	165.120	185.772	208.351	232.999	259.854	289.057			
	P			11.905	12.595	13.265	13.900	14.489	15.016	15.467	15.831	16.092	16.237	16.252			
	A			40.7	42.3	43.8	45.2	46.6	47.9	49.0	50.0	50.8	51.4	51.8			
90	C			93.212	107.165	122.449	139.202	157.565	177.679	199.683	223.717	249.921	278.436	309.402			
	P			11.252	11.842	12.404	12.924	13.389	13.785	14.098	14.314	14.420	14.402	14.247			
	A			39.3	40.7	41.9	43.1	44.1	45.1	45.8	46.4	46.8	46.9	46.8			
BLV2500M6C	4DHR22ME-TSK			25	130	C	66.722	78.531	91.367	105.382	120.727	137.553	156.009	176.249	198.421	222.677	249.169
						P	14.891	16.017	17.143	18.255	19.338	20.378	21.358	22.265	23.084	23.799	24.395
						A	50.6	52.8	55.2	57.6	60.1	62.5	64.8	67.1	69.3	71.3	73.1
		120	C		76.278	88.944	102.750	117.846	134.385	152.516	172.391	194.160	217.975	243.986	272.344		
			P		14.457	15.468	16.470	17.450	18.392	19.281	20.103	20.842	21.484	22.014	22.417		
			A		48.9	51.0	53.2	55.4	57.6	59.7	61.7	63.7	65.5	67.1	68.5		
		110	C		85.321	98.869	113.668	129.871	147.627	167.089	188.406	211.731	237.212	265.003	295.253		
			P		13.943	14.839	15.719	16.568	17.369	18.110	18.773	19.346	19.813	20.159	20.369		
			A		47.4	49.3	51.3	53.2	55.1	56.9	58.6	60.2	61.5	62.7	63.6		
		100	C	93.862	108.316	124.133	141.466	160.466	181.283	204.067	228.971	256.144	285.738	317.904			
			P	13.349	14.133	14.891	15.609	16.272	16.864	17.372	17.779	18.072	18.235	18.253			
			A	45.9	47.7	49.4	51.0	52.6	54.1	55.4	56.5	57.4	58.1	58.5			
		90	C	101.912	117.296	134.156	152.645	172.911	195.108	219.384	245.892	274.781	306.204	340.310			
			P	12.676	13.349	13.987	14.576	15.101	15.547	15.899	16.142	16.262	16.243	16.070			
			A	44.5	46.0	47.4	48.8	50.0	51.0	51.9	52.6	53.0	53.2	53.0			
		BLV3000M6C	4DJNR28ME-TSK	30	130	C	61.113	73.948	87.688	102.413	118.204	135.142	153.307	172.779	193.640	215.969	239.847
						P	13.865	15.164	16.440	17.686	18.889	20.042	21.133	22.153	23.093	23.941	24.689
						A	55.7	59.3	62.8	66.3	69.7	72.9	76.1	79.0	81.6	84.0	86.1
120	C				70.853	84.895	99.881	115.893	133.010	151.313	170.883	191.801	214.146	237.999	263.441		
	P				13.764	14.902	16.013	17.086	18.111	19.080	19.980	20.804	21.541	22.181	22.714		
	A				56.2	59.2	62.1	65.0	67.8	70.5	72.9	75.2	77.2	78.9	80.3		
110	C				80.205	95.301	111.382	128.528	146.819	166.335	187.158	209.368	233.046	258.271	285.125		
	P				13.453	14.439	15.391	16.299	17.154	17.945	18.662	19.297	19.838	20.277	20.602		
	A				55.9	58.4	60.8	63.1	65.3	67.4	69.3	70.9	72.3	73.4	74.1		
100	C			89.156	105.155	122.178	140.305	159.618	180.196	202.120	225.470	250.328	276.773	304.887			
	P			12.967	13.808	14.608	15.359	16.049	16.671	17.213	17.665	18.018	18.263	18.388			
	A			55.0	57.0	58.9	60.7	62.4	63.9	65.3	66.3	67.1	67.6	67.7			
90	C			97.694	114.444	132.257	151.214	171.396	192.883	215.756	240.095	265.981	293.493	322.714			
	P			12.339	13.041	13.698	14.298	14.832	15.291	15.665	15.943	16.115	16.173	16.105			
	A			53.7	55.2	56.6	58.0	59.2	60.2	61.0	61.6	61.8	61.8	61.3			

Modelo	Compresor	H.P	TSC (°F)	TSE °F C=Capacidad kBTu's/h P=Potencia kW A= Amps.													
				-5	0	5	10	15	20	25	30	35	40	45			
BLV3500M6C	60HNR35ME-TSK	35	130	C	99,267	117,779	138,050	160,004	183,567	208,663	235,216	263,152	292,393	322,865	354,493		
				P	22,071	23,605	25,194	26,815	28,445	30,058	31,631	33,141	34,562	35,872	37,047		
				A	74.0	76.6	79.7	83.1	86.9	90.9	94.9	99.0	102.9	106.7	110.1		
			120	C	112,394	131,408	152,458	175,471	200,370	227,080	255,526	285,631	317,321	350,520	385,153		
				P	21,240	22,599	24,007	25,439	26,871	28,279	29,639	30,928	32,121	33,194	34,124		
				A	70.9	73.3	76.2	79.4	82.8	86.4	90.0	93.6	97.0	100.1	102.9		
			110	C	124,651	144,274	166,211	190,389	216,731	245,162	275,607	307,990	342,236	378,268	416,013		
				P	20,246	21,444	22,682	23,936	25,183	26,399	27,558	28,639	29,616	30,465	31,164		
				A	67.7	70.0	72.6	75.5	78.6	81.8	85.0	88.0	90.8	93.3	95.4		
			100	C	136,256	156,594	179,525	204,975	232,867	263,127	295,678	330,445	367,353	406,326	447,289		
				P	19,127	20,176	21,258	22,347	23,422	24,457	25,429	26,313	27,086	27,725	28,204		
				A	64.5	66.6	69.0	71.6	74.4	77.1	79.8	82.3	84.5	86.4	87.8		
		90	C	147,424	168,585	192,618	219,446	248,995	281,190	315,954	353,212	392,890	434,910	479,199			
			P	17,923	18,835	19,772	20,710	21,625	22,492	23,288	23,989	24,571	25,011	25,283			
			A	61.5	63.4	65.5	67.8	70.2	72.5	74.7	76.6	78.2	79.4	80.1			
		BLV4000M6C	60D.NR40ME-TSN	40	130	C	118,773	140,129	163,793	189,642	217,558	247,419	279,106	312,498	347,475	383,916	421,702
						P	26,909	28,702	30,582	32,518	34,476	36,425	38,333	40,166	41,893	43,482	44,898
						A	90.2	93.1	96.7	100.8	105.3	110.1	115.0	119.9	124.8	129.4	133.6
					120	C	133,569	155,703	180,458	207,713	237,348	269,243	303,277	339,331	377,283	417,014	458,403
						P	25,819	27,412	29,083	30,797	32,524	34,231	35,885	37,455	38,906	40,208	41,329
						A	86.1	88.9	92.2	96.1	100.2	104.6	109.0	113.3	117.5	121.4	124.8
					110	C	147,544	170,558	196,506	225,269	256,726	290,757	327,241	366,059	407,089	450,212	495,307
						P	24,507	25,915	27,389	28,897	30,406	31,883	33,297	34,616	35,806	36,835	37,672
						A	81.9	84.5	87.6	91.1	94.9	98.8	102.6	106.4	109.9	113.0	115.5
100	C				160,937	184,933	212,178	242,551	275,932	312,202	351,238	392,922	437,133	483,750	532,653		
	P				23,038	24,273	25,564	26,878	28,182	29,444	30,631	31,712	32,654	33,424	33,991		
	A				77.7	80.1	82.9	86.1	89.4	92.8	96.1	99.2	102.0	104.3	106.0		
90	C			173,987	199,067	227,711	259,797	295,205	333,815	375,507	420,159	467,653	517,867	570,681			
	P			21,471	22,548	23,669	24,802	25,915	26,975	27,949	28,806	29,513	30,037	30,347			
	A			73.6	75.8	78.4	81.2	84.1	86.9	89.6	92.0	94.0	95.5	96.3			

Modelo	Compresor	H.P	TSC (°F)		TSE °F C=Capacidad kBtu/s/h P=Potencia kW A= Amps.												
					-45	-40	-35	-30	-25	-20	-15	-10	-5	0	5		
BLV1200L6D	4DBNF54KE-TSK	12	130	C	3,544	8,436	13,810	19,675	26,041	32,916	40,309	48,229	56,683	65,682	75,233		
				P	4,868	5,781	6,744	7,746	8,775	9,821	10,871	11,916	12,944	13,943	14,903		
				A	10.7	11.9	13.1	14.3	15.5	16.7	17.9	19.1	20.3	21.5	22.7		
			120	C	9,654	14,448	19,815	25,765	32,307	39,448	47,198	55,565	64,558	74,186	84,458		
				P	5,353	6,176	7,046	7,951	8,879	9,821	10,763	11,696	12,608	13,488	14,325		
				A	11.4	12.5	13.5	14.6	15.6	16.7	17.8	18.9	19.9	21.0	22.1		
			110	C	14,962	19,688	25,079	31,143	37,889	45,326	53,463	62,308	71,870	82,158	93,180		
				P	5,649	6,389	7,171	7,985	8,818	9,660	10,500	11,326	12,128	12,894	13,613		
				A	11.7	12.7	13.6	14.5	15.4	16.4	17.3	18.3	19.3	20.2	21.2		
		100	C	19,506	24,195	29,638	35,847	42,828	50,591	59,144	68,497	78,657	89,634	101,437			
			P	5,783	6,445	7,145	7,872	8,615	9,364	10,107	10,832	11,529	12,187	12,794			
			A	11.8	12.6	13.3	14.2	15.0	15.8	16.6	17.5	18.3	19.2	20.0			
		90	C	23,325	28,005	33,532	39,914	47,160	55,279	64,279	74,169	84,958	96,654	109,267			
			P	5,778	6,367	6,990	7,637	8,296	8,957	9,608	10,238	10,836	11,390	11,891			
			A	11.6	12.3	13.0	13.7	14.4	15.1	15.8	16.5	17.3	18.0	18.8			
		BLV1500L6D	4DBNF63KE-TSK	15	130	C	3,233	11,559	19,444	27,053	34,551	42,103	49,874	58,028	66,731	76,148	86,443
						P	4,023	6,240	8,146	9,788	11,209	12,454	13,568	14,596	15,582	16,571	17,608
						A	11.4	13.9	16.2	18.1	19.7	21.2	22.5	23.7	24.8	25.9	27.1
120	C				9,980	17,921	25,573	33,099	40,664	48,433	56,572	65,245	74,616	84,852	96,116		
	P				4,727	6,719	8,415	9,859	11,094	12,167	13,122	14,003	14,856	15,724	16,653		
	A				12.3	14.6	16.5	18.2	19.6	20.9	22.0	23.0	24.1	25.1	26.2		
110	C				16,312	23,920	31,388	38,881	46,563	54,600	63,156	72,397	82,487	93,592	105,875		
	P				5,230	7,015	8,517	9,779	10,847	11,764	12,576	13,327	14,062	14,827	15,665		
	A				12.8	14.8	16.5	17.9	19.2	20.2	21.2	22.1	23.0	24.0	25.0		
100	C			22,071	29,395	36,730	44,239	52,088	60,443	69,467	79,326	90,185	102,208	115,560			
	P			5,567	7,162	8,486	9,584	10,500	11,278	11,964	12,602	13,237	13,914	14,677			
	A			13.0	14.8	16.2	17.5	18.5	19.4	20.2	21.0	21.8	22.7	23.7			
90	C			27,097	34,187	41,437	49,013	57,080	65,802	75,344	85,871	97,548	110,540	125,012			
	P			5,773	7,195	8,358	9,308	10,088	10,744	11,321	11,862	12,414	13,020	13,725			
	A			13.1	14.6	15.8	16.8	17.7	18.4	19.1	19.8	20.5	21.3	22.3			
BLV2200L6D	4DBNF76KE-TSK			22	130	C	3,090	13,117	22,520	31,625	40,754	50,230	60,377	71,519	83,979	98,081	114,148
						P	6,436	8,367	10,136	11,770	13,298	14,746	16,144	17,519	18,899	20,312	21,787
						A	14.9	17.3	19.4	21.4	23.3	25.0	26.7	28.4	30.1	32.0	34.0
		120	C		11,641	21,463	30,778	39,910	49,183	58,920	69,444	81,079	94,149	108,976	125,885		
			P		7,085	8,837	10,430	11,889	13,245	14,524	15,755	16,965	18,183	19,437	20,754		
			A		15.8	17.9	19.9	21.6	23.2	24.7	26.2	27.7	29.2	30.9	32.7		
		110	C		19,360	29,053	38,355	47,591	57,083	67,156	78,133	90,337	104,091	119,720	137,547		
			P		7,542	9,127	10,555	11,852	13,047	14,169	15,245	16,303	17,371	18,477	19,649		
			A		16.3	18.2	19.9	21.4	22.8	24.1	25.3	26.6	28.0	29.5	31.2		
		100	C	26,215	35,854	45,219	54,634	64,422	74,906	86,411	99,259	113,775	130,281	149,101			
			P	7,819	9,249	10,523	11,670	12,717	13,693	14,626	15,543	16,472	17,443	18,481			
			A	16.5	18.2	19.6	20.9	22.1	23.2	24.3	25.4	26.6	27.9	29.5			
		90	C	32,173	41,834	51,337	61,007	71,166	82,138	94,246	107,815	123,167	140,626	160,515			
			P	7,927	9,213	10,346	11,354	12,265	13,108	13,909	14,697	15,500	16,347	17,264			
			A	16.5	18.0	19.2	20.3	21.3	22.2	23.1	24.1	25.1	26.3	27.7			
		BLV2700L6D	6DBNF93KE-TSK	27	130	C	3,283	14,429	25,345	36,296	47,550	59,374	72,035	85,800	100,937	117,712	136,392
						P	15,590	15,103	15,168	15,710	16,655	17,928	19,454	21,159	22,967	24,803	26,594
						A	27.5	27.2	27.4	28.2	29.3	30.8	32.7	34.7	37.0	39.5	42.0
120	C				15,053	25,835	36,539	47,432	58,782	70,856	83,921	98,243	114,091	131,731	151,429		
	P				14,831	14,494	14,668	15,277	16,248	17,504	18,972	20,576	22,242	23,895	25,461		
	A				26.7	26.6	26.9	27.7	28.8	30.3	32.0	34.0	36.1	38.3	40.6		
110	C				24,761	35,268	45,852	56,779	68,316	80,731	94,290	109,262	125,911	144,507	165,316		
	P				14,013	13,814	14,083	14,746	15,728	16,955	18,351	19,843	21,354	22,811	24,138		
	A				25.7	25.7	26.1	26.9	28.0	29.4	31.0	32.8	34.7	36.7	38.7		
100	C			32,683	43,007	53,562	64,613	76,429	89,276	103,421	119,132	136,675	156,318	178,327			
	P			13,152	13,076	13,428	14,132	15,114	16,298	17,610	18,975	20,318	21,565	22,641			
	A			24.6	24.6	25.1	25.9	27.0	28.3	29.8	31.4	33.1	34.9	36.5			
90	C			39,094	49,327	59,944	71,211	83,396	96,766	111,589	128,130	146,658	167,439	190,741			
	P			12,263	12,299	12,721	13,452	14,420	15,548	16,763	17,989	19,151	20,176	20,987			
	A			23.4	23.5	24.0	24.8	25.9	27.1	28.5	29.9	31.4	32.8	34.2			

Modelo	Compresor	H.P	TSC (°F)	TSE °F C=Capacidad kBtu's/h P=Potencia kW A= Amps.											
				-45	-40	-35	-30	-25	-20	-15	-10	-5	0	5	
BLV3000L6D	6DJNF1ME-TSK	30	130	C	1,469	15,926	29,845	43,584	57,503	71,960	87,313	103,923	122,147	142,344	164,873
				P	16,098	16,437	17,191	18,306	19,727	21,399	23,266	25,274	27,367	29,490	31,588
				A	27.6	29.0	30.5	32.2	34.1	36.1	38.3	40.7	43.3	46.1	49.1
			120	C	16,208	30,097	43,649	57,221	71,173	85,863	101,650	118,894	137,952	159,183	182,947
				P	15,645	16,048	16,831	17,940	19,319	20,914	22,669	24,529	26,439	28,343	30,187
				A	27.5	28.8	30.3	31.8	33.6	35.5	37.5	39.7	42.0	44.6	47.3
			110	C	28,400	41,841	55,145	68,670	82,776	97,819	114,160	132,158	152,170	174,556	199,674
				P	15,071	15,529	16,333	17,428	18,757	20,266	21,901	23,604	25,322	27,000	28,582
				A	27.0	28.2	29.6	31.1	32.7	34.4	36.3	38.2	40.4	42.6	45.0
			100	C	38,376	51,490	64,667	78,265	92,644	108,161	125,176	144,047	165,133	188,793	215,386
				P	14,395	14,902	15,718	16,789	18,061	19,476	20,981	22,520	24,039	25,481	26,792
				A	26.2	27.4	28.7	30.1	31.6	33.1	34.8	36.5	38.4	40.4	42.5
			90	C	46,470	59,376	72,546	86,337	101,109	117,219	135,028	154,893	177,174	202,228	230,416
				P	13,639	14,185	15,005	16,046	17,250	18,564	19,931	21,298	22,608	23,806	24,839
				A	25.4	26.5	27.7	29.0	30.3	31.7	33.1	34.7	36.3	38.0	39.8

Modelo	Compresor	H.P	TSC (°F)	TSE °F C=Capacidad kBtu's/h P=Potencia kW A= Amps.													
				-45	-40	-35	-30	-25	-20	-15	-10	-5	0	5			
BLV200L6C	40BNF54KE-TSK	12	130	C	3,544	8,436	13,810	19,675	26,041	32,916	40,309	48,229	56,683	65,682	75,233		
				P	4,868	5,781	6,744	7,746	8,775	9,821	10,871	11,916	12,944	13,943	14,903		
				A	21.5	23.8	26.2	28.6	31.0	33.4	35.8	38.2	40.6	43.0	45.4		
			120	C	9,654	14,448	19,815	25,765	32,307	39,448	47,198	55,565	64,558	74,186	84,458		
				P	5,353	6,176	7,046	7,951	8,879	9,821	10,763	11,696	12,608	13,488	14,325		
				A	22.9	25.0	27.1	29.2	31.3	33.4	35.6	37.7	39.9	42.1	44.2		
			110	C	14,962	19,688	25,079	31,143	37,889	45,326	53,463	62,308	71,870	82,158	93,180		
				P	5,649	6,389	7,171	7,985	8,818	9,660	10,500	11,326	12,128	12,894	13,613		
				A	23.5	25.3	27.1	29.0	30.9	32.8	34.7	36.6	38.5	40.4	42.4		
		100	C	19,506	24,195	29,638	35,847	42,828	50,591	59,144	68,497	78,657	89,634	101,437			
			P	5,783	6,445	7,145	7,872	8,615	9,364	10,107	10,832	11,529	12,187	12,794			
			A	23.5	25.1	26.7	28.3	29.9	31.6	33.3	34.9	36.6	38.3	40.1			
		90	C	23,325	28,005	33,532	39,914	47,160	55,279	64,279	74,169	84,958	96,654	109,267			
			P	5,778	6,367	6,990	7,637	8,296	8,957	9,608	10,238	10,850	11,390	11,891			
			A	23.3	24.6	25.9	27.3	28.7	30.1	31.6	33.0	34.5	36.0	37.5			
		BLV1500L6C	40HNF63KE-TSK	15	130	C	3,233	11,559	19,444	27,053	34,551	42,103	49,874	58,028	66,731	76,148	86,443
						P	4,023	6,240	8,146	9,788	11,209	12,454	13,568	14,596	15,582	16,571	17,608
						A	22.8	27.9	32.3	36.2	39.5	42.4	45.0	47.3	49.6	51.9	54.2
120	C				9,980	17,921	25,573	33,099	40,664	48,433	56,572	65,245	74,616	84,852	96,116		
	P				4,727	6,719	8,415	9,859	11,094	12,167	13,122	14,003	14,856	15,724	16,653		
	A				24.6	29.1	33.0	36.4	39.2	41.7	44.0	46.1	48.1	50.2	52.4		
110	C				16,312	23,920	31,388	38,881	46,563	54,600	63,156	72,397	82,487	93,592	105,875		
	P				5,230	7,015	8,517	9,779	10,847	11,764	12,576	13,327	14,062	14,827	15,665		
	A				25.6	29.6	33.0	35.9	38.3	40.5	42.4	44.2	46.0	47.9	50.0		
100	C			22,071	29,395	36,730	44,239	52,088	60,443	69,467	79,326	90,185	102,208	115,560			
	P			5,567	7,162	8,486	9,584	10,500	11,278	11,964	12,602	13,237	13,914	14,677			
	A			26.1	29.6	32.5	34.9	37.0	38.8	40.4	42.0	43.6	45.3	47.3			
90	C			27,097	34,187	41,437	49,013	57,080	65,802	75,344	85,871	97,548	110,540	125,012			
	P			5,773	7,195	8,358	9,308	10,088	10,744	11,321	11,862	12,414	13,020	13,725			
	A			26.2	29.2	31.7	33.7	35.4	36.9	38.2	39.6	41.0	42.6	44.5			
BLV2200L6C	40JNF76KE-TSK			22	130	C	3,090	13,117	22,520	31,625	40,754	50,230	60,377	71,519	83,979	98,081	114,148
						P	6,436	8,367	10,136	11,770	13,298	14,746	16,144	17,519	18,899	20,312	21,787
						A	29.7	34.5	38.9	42.8	46.5	50.0	53.4	56.8	60.3	64.0	68.0
		120	C		11,641	21,463	30,778	39,910	49,183	58,920	69,444	81,079	94,149	108,976	125,885		
			P		7,085	8,837	10,430	11,889	13,245	14,524	15,755	16,965	18,183	19,437	20,754		
			A		31.6	35.9	39.7	43.2	46.4	49.4	52.4	55.3	58.4	61.8	65.4		
		110	C		19,360	29,053	38,355	47,591	57,083	67,156	78,133	90,337	104,091	119,720	137,547		
			P		7,542	9,127	10,555	11,852	13,047	14,169	15,245	16,303	17,371	18,477	19,649		
			A		32.6	36.4	39.8	42.8	45.5	48.1	50.7	53.3	56.0	59.0	62.3		
		100	C	26,215	35,854	45,219	54,634	64,422	74,906	86,411	99,259	113,775	130,281	149,101			
			P	7,819	9,249	10,523	11,670	12,717	13,693	14,626	15,543	16,472	17,443	18,481			
			A	33.0	36.4	39.3	41.9	44.2	46.4	48.6	50.8	53.2	55.9	58.9			
		90	C	32,173	41,834	51,337	61,007	71,166	82,138	94,246	107,815	123,167	140,626	160,515			
			P	7,927	9,213	10,346	11,354	12,265	13,108	13,909	14,697	15,500	16,347	17,264			
			A	33.0	35.9	38.4	40.6	42.6	44.4	46.3	48.2	50.3	52.6	55.4			
		BLV2700L6C	60HNF93KE-TSK	27	130	C	3,283	14,429	25,345	36,296	47,550	59,374	72,035	85,800	100,937	117,712	136,392
						P	15,590	15,103	15,168	15,710	16,655	17,928	19,454	21,159	22,967	24,803	26,594
						A	55.0	54.4	54.9	56.3	58.6	61.7	65.3	69.5	74.1	79.0	84.0
120	C				15,053	25,835	36,539	47,432	58,782	70,856	83,921	98,243	114,091	131,731	151,429		
	P				14,831	14,494	14,668	15,277	16,248	17,504	18,972	20,576	22,242	23,895	25,461		
	A				53.5	53.2	53.8	55.4	57.7	60.6	64.1	68.0	72.2	76.6	81.1		
110	C				24,761	35,268	45,852	56,779	68,316	80,731	94,290	109,262	125,911	144,507	165,316		
	P				14,013	13,814	14,083	14,746	15,728	16,955	18,351	19,843	21,354	22,811	24,138		
	A				51.5	51.4	52.2	53.8	56.0	58.8	62.1	65.7	69.5	73.4	77.4		
100	C			32,683	43,007	53,562	64,613	76,429	89,276	103,421	119,132	136,675	156,318	178,327			
	P			13,152	13,076	13,428	14,132	15,114	16,298	17,610	18,975	20,318	21,565	22,641			
	A			49.1	49.2	50.2	51.8	54.0	56.6	59.6	62.9	66.3	69.7	73.1			
90	C			39,094	49,327	59,944	71,211	83,396	96,766	111,589	128,130	146,658	167,439	190,741			
	P			12,263	12,299	12,721	13,452	14,420	15,548	16,763	17,989	19,151	20,176	20,987			
	A			46.7	47.0	48.0	49.6	51.7	54.2	56.9	59.8	62.8	65.7	68.4			

Modelo	Compresor	H.P	TSC (°F)	TSE °F C=Capacidad kBtu's/h P=Potencia kW A= Amps.											
				-45	-40	-35	-30	-25	-20	-15	-10	-5	0	5	
BLV3000L6C	6DJNF1ME-TSK	30	130	C	1,469	15,926	29,845	43,584	57,503	71,960	87,313	103,923	122,147	142,344	164,873
				P	16,098	16,437	17,191	18,306	19,727	21,399	23,266	25,274	27,367	29,490	31,588
				A	55.1	57.9	61.0	64.4	68.1	72.2	76.6	81.4	86.6	92.2	98.1
			120	C	16,208	30,097	43,649	57,221	71,173	85,863	101,650	118,894	137,952	159,183	182,947
				P	15,645	16,048	16,831	17,940	19,319	20,914	22,669	24,529	26,439	28,343	30,187
				A	54.9	57.6	60.5	63.7	67.2	70.9	75.0	79.4	84.1	89.1	94.5
			110	C	28,400	41,841	55,145	68,670	82,776	97,819	114,160	132,158	152,170	174,556	199,674
				P	15,071	15,529	16,333	17,428	18,757	20,266	21,901	23,604	25,322	27,000	28,582
				A	53.9	56.5	59.2	62.2	65.4	68.8	72.5	76.5	80.7	85.2	90.1
			100	C	38,376	51,490	64,667	78,265	92,644	108,161	125,176	144,047	165,133	188,793	215,386
				P	14,395	14,902	15,718	16,789	18,061	19,476	20,981	22,520	24,039	25,481	26,792
				A	52.4	54.9	57.4	60.2	63.1	66.2	69.5	73.1	76.8	80.8	85.0
			90	C	46,470	59,376	72,546	86,337	101,109	117,219	135,028	154,893	177,174	202,228	230,416
				P	13,639	14,185	15,005	16,046	17,250	18,564	19,931	21,298	22,608	23,806	24,839
				A	50.7	53.0	55.4	57.9	60.6	63.3	66.2	69.3	72.6	76.0	79.6

MODELO BLV

COMPRESOR COPELAND

R-449A | 230V

Modelo	Compresor	H.P	TSC (°F)	TSE °F C=Capacidad kBtu's/h P=Potencia kW A= Amps.													
				-45	-40	-35	-30	-25	-20	-15	-10	-5	0			5	
BLV200L6C	40BNF54KE-TSK	12	130	C	3,544	8,436	13,810	19,675	26,041	32,916	40,309	48,229	56,683	65,682	75,233		
				P	4,868	5,781	6,744	7,746	8,775	9,821	10,871	11,916	12,944	13,943	14,903		
				A	21.5	23.8	26.2	28.6	31.0	33.4	35.8	38.2	40.6	43.0	45.4		
			120	C	9,654	14,448	19,815	25,765	32,307	39,448	47,198	55,565	64,558	74,186	84,458		
				P	5,353	6,176	7,046	7,951	8,879	9,821	10,763	11,696	12,608	13,488	14,325		
				A	22.9	25.0	27.1	29.2	31.3	33.4	35.6	37.7	39.9	42.1	44.2		
			110	C	14,962	19,688	25,079	31,143	37,889	45,326	53,463	62,308	71,870	82,158	93,180		
				P	5,649	6,389	7,171	7,985	8,818	9,660	10,500	11,326	12,128	12,894	13,613		
				A	23.5	25.3	27.1	29.0	30.9	32.8	34.7	36.6	38.5	40.4	42.4		
		100	C	19,506	24,195	29,638	35,847	42,828	50,591	59,144	68,497	78,657	89,634	101,437			
			P	5,783	6,445	7,145	7,872	8,615	9,364	10,107	10,832	11,529	12,187	12,794			
			A	23.5	25.1	26.7	28.3	29.9	31.6	33.3	34.9	36.6	38.3	40.1			
		90	C	23,325	28,005	33,532	39,914	47,160	55,279	64,279	74,169	84,958	96,654	109,267			
			P	5,778	6,367	6,990	7,637	8,296	8,957	9,608	10,238	10,850	11,390	11,891			
			A	23.3	24.6	25.9	27.3	28.7	30.1	31.6	33.0	34.5	36.0	37.5			
		BLV1500L6C	40HNF63KE-TSK	15	130	C	3,233	11,559	19,444	27,053	34,551	42,103	49,874	58,028	66,731	76,148	86,443
						P	4,023	6,240	8,146	9,788	11,209	12,454	13,568	14,596	15,582	16,571	17,608
						A	22.8	27.9	32.3	36.2	39.5	42.4	45.0	47.3	49.6	51.9	54.2
120	C				9,980	17,921	25,573	33,099	40,664	48,433	56,572	65,245	74,616	84,852	96,116		
	P				4,727	6,719	8,415	9,859	11,094	12,167	13,122	14,003	14,856	15,724	16,653		
	A				24.6	29.1	33.0	36.4	39.2	41.7	44.0	46.1	48.1	50.2	52.4		
110	C				16,312	23,920	31,388	38,881	46,563	54,600	63,156	72,397	82,487	93,592	105,875		
	P				5,230	7,015	8,517	9,779	10,847	11,764	12,576	13,327	14,062	14,827	15,665		
	A				25.6	29.6	33.0	35.9	38.3	40.5	42.4	44.2	46.0	47.9	50.0		
100	C			22,071	29,395	36,730	44,239	52,088	60,443	69,467	79,326	90,185	102,208	115,560			
	P			5,567	7,162	8,486	9,584	10,500	11,278	11,964	12,602	13,237	13,914	14,677			
	A			26.1	29.6	32.5	34.9	37.0	38.8	40.4	42.0	43.6	45.3	47.3			
90	C			27,097	34,187	41,437	49,013	57,080	65,802	75,344	85,871	97,548	110,540	125,012			
	P			5,773	7,195	8,358	9,308	10,088	10,744	11,321	11,862	12,414	13,020	13,725			
	A			26.2	29.2	31.7	33.7	35.4	36.9	38.2	39.6	41.0	42.6	44.5			
BLV2200L6C	40JNF76KE-TSK			22	130	C	3,090	13,117	22,520	31,625	40,754	50,230	60,377	71,519	83,979	98,081	114,148
						P	6,436	8,367	10,136	11,770	13,298	14,746	16,144	17,519	18,899	20,312	21,787
						A	29.7	34.5	38.9	42.8	46.5	50.0	53.4	56.8	60.3	64.0	68.0
		120	C		11,641	21,463	30,778	39,910	49,183	58,920	69,444	81,079	94,149	108,976	125,885		
			P		7,085	8,837	10,430	11,889	13,245	14,524	15,755	16,965	18,183	19,437	20,754		
			A		31.6	35.9	39.7	43.2	46.4	49.4	52.4	55.3	58.4	61.8	65.4		
		110	C		19,360	29,053	38,355	47,591	57,083	67,156	78,133	90,337	104,091	119,720	137,547		
			P		7,542	9,127	10,555	11,852	13,047	14,169	15,245	16,303	17,371	18,477	19,649		
			A		32.6	36.4	39.8	42.8	45.5	48.1	50.7	53.3	56.0	59.0	62.3		
		100	C	26,215	35,854	45,219	54,634	64,422	74,906	86,411	99,259	113,775	130,281	149,101			
			P	7,819	9,249	10,523	11,670	12,717	13,693	14,626	15,543	16,472	17,443	18,481			
			A	33.0	36.4	39.3	41.9	44.2	46.4	48.6	50.8	53.2	55.9	58.9			
		90	C	32,173	41,834	51,337	61,007	71,166	82,138	94,246	107,815	123,167	140,626	160,515			
			P	7,927	9,213	10,346	11,354	12,265	13,108	13,909	14,697	15,500	16,347	17,264			
			A	33.0	35.9	38.4	40.6	42.6	44.4	46.3	48.2	50.3	52.6	55.4			
		BLV2700L6C	60HNF93KE-TSK	27	130	C	3,283	14,429	25,345	36,296	47,550	59,374	72,035	85,800	100,937	117,712	136,392
						P	15,590	15,103	15,168	15,710	16,655	17,928	19,454	21,159	22,967	24,803	26,594
						A	55.0	54.4	54.9	56.3	58.6	61.7	65.3	69.5	74.1	79.0	84.0
120	C				15,053	25,835	36,539	47,432	58,782	70,856	83,921	98,243	114,091	131,731	151,429		
	P				14,831	14,494	14,668	15,277	16,248	17,504	18,972	20,576	22,242	23,895	25,461		
	A				53.5	53.2	53.8	55.4	57.7	60.6	64.1	68.0	72.2	76.6	81.1		
110	C				24,761	35,268	45,852	56,779	68,316	80,731	94,290	109,262	125,911	144,507	165,316		
	P				14,013	13,814	14,083	14,746	15,728	16,955	18,351	19,843	21,354	22,811	24,138		
	A				51.5	51.4	52.2	53.8	56.0	58.8	62.1	65.7	69.5	73.4	77.4		
100	C			32,683	43,007	53,562	64,613	76,429	89,276	103,421	119,132	136,675	156,318	178,327			
	P			13,152	13,076	13,428	14,132	15,114	16,298	17,610	18,975	20,318	21,565	22,641			
	A			49.1	49.2	50.2	51.8	54.0	56.6	59.6	62.9	66.3	69.7	73.1			
90	C			39,094	49,327	59,944	71,211	83,396	96,766	111,589	128,130	146,658	167,439	190,741			
	P			12,263	12,299	12,721	13,452	14,420	15,548	16,763	17,989	19,151	20,176	20,987			
	A			46.7	47.0	48.0	49.6	51.7	54.2	56.9	59.8	62.8	65.7	68.4			

Modelo	Compresor	H.P	TSC (°F)	TSE °F C=Capacidad kBtu's/h P=Potencia kW A= Amps.											
				-45	-40	-35	-30	-25	-20	-15	-10	-5	0	5	
BLV3000L6C	6DJNF1ME-TSK	30	130	C	1,469	15,926	29,845	43,584	57,503	71,960	87,313	103,923	122,147	142,344	164,873
				P	16,098	16,437	17,191	18,306	19,727	21,399	23,266	25,274	27,367	29,490	31,588
				A	55.1	57.9	61.0	64.4	68.1	72.2	76.6	81.4	86.6	92.2	98.1
			120	C	16,208	30,097	43,649	57,221	71,173	85,863	101,650	118,894	137,952	159,183	182,947
				P	15,645	16,048	16,831	17,940	19,319	20,914	22,669	24,529	26,439	28,343	30,187
				A	54.9	57.6	60.5	63.7	67.2	70.9	75.0	79.4	84.1	89.1	94.5
			110	C	28,400	41,841	55,145	68,670	82,776	97,819	114,160	132,158	152,170	174,556	199,674
				P	15,071	15,529	16,333	17,428	18,757	20,266	21,901	23,604	25,322	27,000	28,582
				A	53.9	56.5	59.2	62.2	65.4	68.8	72.5	76.5	80.7	85.2	90.1
			100	C	38,376	51,490	64,667	78,265	92,644	108,161	125,176	144,047	165,133	188,793	215,386
				P	14,395	14,902	15,718	16,789	18,061	19,476	20,981	22,520	24,039	25,481	26,792
				A	52.4	54.9	57.4	60.2	63.1	66.2	69.5	73.1	76.8	80.8	85.0
			90	C	46,470	59,376	72,546	86,337	101,109	117,219	135,028	154,893	177,174	202,228	230,416
				P	13,639	14,185	15,005	16,046	17,250	18,564	19,931	21,298	22,608	23,806	24,839
				A	50.7	53.0	55.4	57.9	60.6	63.3	66.2	69.3	72.6	76.0	79.6

MODELO BLV

COMPRESOR COPELAND

R-404A | 460V

Modelo	Compresor	H.P	TSC (°F)	TSE °F C=Capacidad kBtu's/h P=Potencia kW A= Amps.													
				-5	0	5	10	15	20	25	30	35	40	45			
JLD300BM6D	4PES-15Y	30	130	C	36.5	43.6	51.6	60.6	70.6	81.9	94.5	108.5	124.0	141.0	159.7		
				P	8.4	9.3	10.2	11.0	11.8	12.6	13.3	14.0	14.6	15.2	15.7		
				A	14.6	15.4	16.3	17.2	18.1	19.0	19.8	20.6	21.4	22.1	22.7		
			120	C	43.3	51.2	60.0	70.0	81.1	93.4	107.1	122.3	139.0	157.4	177.5		
				P	8.4	9.2	10.0	10.8	11.5	12.1	12.7	13.3	13.8	14.3	14.7		
				A	14.6	15.4	16.1	16.9	17.7	18.4	19.2	19.8	20.4	21.0	21.5		
		110	C	50.2	58.9	68.6	79.5	91.6	105.0	119.9	136.2	154.1	173.8	195.3			
			P	8.4	9.1	9.8	10.4	11.0	11.6	12.1	12.5	12.9	13.3	13.5			
			A	14.5	15.2	15.9	16.5	17.2	17.8	18.4	18.9	19.4	19.8	20.1			
		100	C	57.3	66.8	77.4	89.2	102.2	116.7	132.7	150.2	169.4	190.3	213.1			
			P	8.2	8.8	9.4	9.9	10.4	10.9	11.3	11.7	11.9	12.2	12.3			
			A	14.3	14.9	15.5	16.0	16.6	17.1	17.5	17.9	18.3	18.5	18.7			
		90	C	64.4	74.7	86.2	98.9	113.0	128.5	145.5	164.2	184.7	206.9	231.1			
			P	7.9	8.4	8.9	9.4	9.8	10.1	10.4	10.6	10.8	10.9	10.9			
			A	14.0	14.5	15.0	15.5	15.9	16.3	16.6	16.8	17.0	17.1	17.1			
		JLD400BM6D	4NES-20Y	40	130	C	46.6	55.0	64.3	74.9	86.8	100.0	114.7	131.0	149.1	169.0	190.8
						P	10.3	11.3	12.3	13.2	14.1	14.9	15.8	16.5	17.2	17.9	18.4
						A	16.8	17.8	18.8	19.8	20.8	21.8	22.8	23.7	24.6	25.4	26.1
120	C				54.4	63.6	74.0	85.6	98.6	113.1	129.1	146.8	166.2	187.6	211.0		
	P				10.2	11.1	12.0	12.8	13.6	14.4	15.0	15.7	16.3	16.8	17.2		
	A				16.7	17.6	18.5	19.4	20.3	21.1	21.9	22.7	23.4	24.0	24.6		
110	C			62.2	72.4	83.8	96.5	110.6	126.2	143.5	162.5	183.4	206.3	231.2			
	P			10.0	10.8	11.6	12.3	13.0	13.6	14.2	14.7	15.2	15.5	15.8			
	A			16.5	17.3	18.1	18.8	19.6	20.3	20.9	21.5	22.1	22.5	22.9			
100	C			70.1	81.2	93.6	107.3	122.6	139.5	158.0	178.4	200.7	225.1	251.6			
	P			9.8	10.5	11.1	11.7	12.3	12.8	13.3	13.6	14.0	14.2	14.3			
	A			16.2	16.9	17.6	18.2	18.8	19.4	19.9	20.3	20.7	21.0	21.1			
90	C			78.1	90.1	103.5	118.3	134.7	152.8	172.6	194.3	218.1	243.9	272.0			
	P			9.4	10.0	10.5	11.0	11.5	11.9	12.2	12.4	12.6	12.7	12.7			
	A			15.9	16.4	17.0	17.5	18.0	18.4	18.7	19.0	19.2	19.3	19.3			
JLD440BM6D	4JE-22Y			44	130	C	52.1	61.7	72.5	84.4	97.7	112.4	128.7	146.7	166.4	188.0	211.7
						P	12.0	13.0	14.1	15.1	16.1	17.0	17.9	18.8	19.6	20.4	21.1
						A	18.5	19.7	20.8	22.0	23.2	24.3	25.4	26.5	27.6	28.6	29.5
		120	C		61.3	71.9	83.7	96.7	111.2	127.2	144.8	164.2	185.4	208.6	233.8		
			P		11.8	12.7	13.7	14.6	15.5	16.3	17.1	17.9	18.6	19.2	19.8		
			A		18.3	19.3	20.4	21.4	22.5	23.5	24.4	25.4	26.3	27.1	27.9		
		110	C	70.4	82.0	94.8	109.0	124.6	141.9	160.8	181.6	204.3	228.9	255.8			
			P	11.5	12.3	13.2	14.0	14.8	15.5	16.2	16.8	17.4	17.9	18.4			
			A	18.0	18.9	19.8	20.7	21.6	22.5	23.3	24.1	24.8	25.5	26.0			
		100	C	79.5	92.0	105.8	121.1	137.9	156.4	176.6	198.8	222.9	249.1	277.5			
			P	11.1	11.9	12.6	13.3	14.0	14.6	15.2	15.7	16.1	16.5	16.8			
			A	17.6	18.4	19.2	19.9	20.7	21.4	22.1	22.7	23.2	23.7	24.1			
		90	C	88.5	101.9	116.8	133.1	151.0	170.7	192.2	215.7	241.2	268.9	298.9			
			P	10.6	11.3	11.9	12.5	13.1	13.5	14.0	14.4	14.7	14.9	15.1			
			A	17.1	17.8	18.4	19.1	19.7	20.2	20.7	21.2	21.5	21.8	22.0			
		JLD500BM6D	4HE-25Y	50	130	C	64.1	75.2	87.6	101.3	116.6	133.5	152.2	172.8	195.5	220.3	247.4
						P	14.8	15.9	17.1	18.2	19.3	20.3	21.4	22.3	23.2	24.1	24.8
						A	23.4	24.7	26.0	27.3	28.5	29.8	31.0	32.2	33.3	34.4	35.4
120	C				74.6	86.8	100.4	115.5	132.2	150.7	171.0	193.3	217.7	244.4	273.4		
	P				14.4	15.4	16.5	17.5	18.5	19.4	20.3	21.2	21.9	22.6	23.3		
	A				23.0	24.2	25.3	26.5	27.6	28.7	29.8	30.8	31.7	32.6	33.4		
110	C			85.0	98.4	113.2	129.6	147.7	167.6	189.5	213.4	239.6	268.1	299.0			
	P			13.9	14.9	15.8	16.7	17.6	18.4	19.2	19.9	20.5	21.1	21.6			
	A			22.5	23.5	24.6	25.6	26.5	27.5	28.4	29.2	30.0	30.7	31.3			
100	C			95.2	109.7	125.7	143.4	162.9	184.2	207.7	233.2	261.1	291.4	324.2			
	P			13.3	14.2	15.0	15.8	16.6	17.3	17.9	18.5	19.0	19.4	19.7			
	A			21.9	22.8	23.7	24.6	25.4	26.2	26.9	27.6	28.1	28.6	29.0			
90	C			105.3	120.9	138.1	157.0	177.8	200.6	225.5	252.7	282.2	314.3	348.9			
	P			12.7	13.5	14.2	14.8	15.4	16.0	16.5	16.9	17.2	17.5	17.6			
	A			21.3	22.0	22.8	23.5	24.2	24.8	25.3	25.8	26.2	26.5	26.6			
JLD600BM6D	4GE-30Y			60	130	C	74.7	87.2	101.2	116.7	134.0	153.1	174.3	197.6	223.2	251.3	282.0
						P	17.1	18.4	19.7	20.9	22.2	23.4	24.5	25.6	26.6	27.5	28.4
						A	27.9	29.3	30.7	32.2	33.6	35.0	36.4	37.7	39.0	40.2	41.3
		120	C		86.6	100.6	116.0	133.1	152.1	173.0	196.1	221.4	249.1	279.4	312.4		
			P		16.6	17.8	19.0	20.1	21.2	22.3	23.3	24.3	25.1	25.9	26.6		
			A		27.4	28.7	30.0	31.2	32.5	33.8	35.0	36.1	37.2	38.1	39.0		
		110	C	98.4	113.7	130.6	149.3	169.9	192.6	217.5	244.8	274.6	307.0	342.3			
			P	16.0	17.1	18.2	19.2	20.2	21.1	22.0	22.8	23.5	24.1	24.6			
			A	26.8	27.9	29.1	30.2	31.3	32.4	33.4	34.3	35.2	35.9	36.6			
		100	C	110.1	126.6	144.9	165.1	187.3	211.7	238.5	267.7	299.5	334.1	371.6			
			P	15.3	16.3	17.2	18.1	19.0	19.8	20.5	21.1	21.7	22.1	22.5			
			A	26.1	27.1	28.1	29.0	30.0	30.8	31.7	32.4	33.0	33.6	34.0			
		90	C	121.4	139.2	158.9	180.6	204.4	230.4	259.0	290.1	323.9	360.6	400.3			
			P	14.6	15.4	16.2	17.0	17.7	18.3	18.9	19.3	19.7	20.0	20.2			
			A	25.3	26.1	27.0	27.8	28.5	29.2	29.8	30.4	30.8	31.1	31.3			

Modelo	Compresor	H.P	TSC (°F)	TSE °F C=Capacidad kBtu's/h P=Potencia kW A= Amps.														
				-5	0	5	10	15	20	25	30	35	40	45				
JLD660BM6D	6JE-33Y	66	130	C	76.7	91.0	107.1	125.0	144.9	167.0	191.5	218.5	248.2	280.7	316.3			
				P	17.8	19.3	20.8	22.3	23.8	25.2	26.5	27.8	29.0	30.1	31.2			
				A	31.1	32.6	34.2	35.7	37.3	38.9	40.5	42.0	43.4	44.8	46.1			
			120	C	90.3	106.0	123.5	143.0	164.7	188.6	214.9	243.9	275.7	310.4	348.2			
				P	17.5	18.9	20.3	21.7	23.0	24.2	25.4	26.5	27.6	28.5	29.4			
				A	30.8	32.2	33.6	35.0	36.4	37.8	39.2	40.5	41.7	42.8	43.9			
			110	C	103.8	121.0	140.0	161.0	184.3	210.0	238.2	269.1	302.9	339.8	379.8			
				P	17.1	18.4	19.6	20.8	22.0	23.1	24.1	25.0	25.9	26.7	27.3			
				A	30.4	31.6	32.9	34.1	35.4	36.6	37.7	38.8	39.7	40.6	41.4			
			100	C	117.3	135.8	156.3	178.9	203.8	231.2	261.2	294.1	329.9	368.8	411.0			
				P	16.6	17.7	18.8	19.9	20.8	21.8	22.6	23.4	24.0	24.6	25.0			
				A	29.9	30.9	32.0	33.1	34.1	35.1	36.0	36.9	37.6	38.3	38.8			
			90	C	130.7	150.5	172.4	196.5	223.0	252.1	284.0	318.7	356.5	397.5	441.8			
				P	15.9	16.9	17.8	18.7	19.5	20.2	20.9	21.5	21.9	22.3	22.5			
				A	29.2	30.1	31.0	31.9	32.8	33.5	34.2	34.8	35.3	35.7	35.9			
			JLD700BM6D	6HE-35Y	70	130	C	94.3	110.7	129.0	149.3	171.8	196.8	224.4	254.7	288.0	324.5	364.3
							P	21.8	23.6	25.4	27.1	28.8	30.4	32.0	33.5	35.0	36.3	37.5
							A	35.3	37.2	39.2	41.2	43.2	45.1	47.1	48.9	50.7	52.4	54.0
120	C	109.8				127.8	147.8	170.0	194.6	221.7	251.5	284.3	320.1	359.2	401.8			
	P	21.3				22.9	24.5	26.1	27.6	29.1	30.5	31.8	33.0	34.1	35.1			
	A	34.7				36.5	38.2	40.0	41.8	43.5	45.2	46.8	48.3	49.7	51.0			
110	C	125.0				144.6	166.4	190.5	217.0	246.2	278.3	313.4	351.8	393.5	438.9			
	P	20.6				22.1	23.5	24.9	26.3	27.6	28.8	29.9	30.9	31.8	32.5			
	A	34.0				35.5	37.1	38.7	40.2	41.7	43.1	44.5	45.7	46.8	47.7			
100	C	140.0				161.3	184.8	210.7	239.2	270.5	304.8	342.3	383.1	427.5	475.6			
	P	19.8				21.1	22.4	23.6	24.8	25.9	26.8	27.7	28.5	29.1	29.7			
	A	33.1				34.5	35.9	37.2	38.5	39.7	40.9	41.9	42.8	43.6	44.2			
90	C	154.9				177.7	202.9	230.6	261.1	294.5	331.0	370.8	414.1	461.1	511.9			
	P	18.9				20.0	21.1	22.1	23.1	24.0	24.7	25.4	25.9	26.3	26.5			
	A	32.1				33.3	34.5	35.6	36.6	37.6	38.5	39.2	39.8	40.3	40.6			
JLD800BM6D	6GE-40Y	80				130	C	109.7	128.1	148.6	171.2	196.3	223.9	254.4	287.9	324.7	364.9	408.7
							P	25.5	27.5	29.4	31.3	33.2	35.0	36.7	38.4	39.9	41.3	42.7
							A	43.7	45.7	47.7	49.8	51.8	53.8	55.7	57.6	59.4	61.0	62.6
			120	C	127.3	147.7	170.1	195.0	222.4	252.6	285.8	322.2	362.0	405.4	452.7			
				P	24.8	26.7	28.4	30.2	31.9	33.5	35.0	36.4	37.8	39.0	40.1			
				A	43.0	44.8	46.7	48.5	50.3	52.1	53.8	55.4	56.9	58.3	59.5			
			110	C	144.5	166.7	191.2	218.2	248.0	280.8	316.7	356.0	398.8	445.5	496.1			
				P	24.0	25.7	27.3	28.8	30.3	31.7	33.1	34.3	35.4	36.3	37.2			
				A	42.2	43.8	45.5	47.1	48.7	50.2	51.7	53.0	54.2	55.3	56.2			
			100	C	161.3	185.3	211.9	241.1	273.3	308.6	347.2	389.4	435.3	485.2	539.2			
				P	23.1	24.6	26.0	27.3	28.6	29.8	30.9	31.9	32.7	33.4	34.0			
				A	41.2	42.7	44.1	45.5	46.9	48.1	49.3	50.4	51.3	52.1	52.7			
			90	C	177.9	203.8	232.3	263.8	298.3	336.2	377.6	422.6	471.6	524.7	582.2			
				P	22.0	23.3	24.5	25.6	26.7	27.6	28.5	29.2	29.8	30.2	30.5			
				A	40.2	41.4	42.6	43.8	44.9	45.9	46.8	47.6	48.2	48.6	48.9			
			JLD1000BM6D	6FE-50Y	100	130	C	135.4	157.9	182.7	210.1	240.3	273.5	310.1	350.2	394.1	442.2	494.5
							P	30.6	32.9	35.3	37.5	39.7	41.9	44.0	46.0	47.8	49.6	51.1
							A	60.6	63.1	65.6	68.0	70.3	72.5	74.6	76.5	78.3	79.9	81.3
120	C	156.7				181.5	208.8	238.9	272.0	308.4	348.4	392.2	440.0	492.1	548.8			
	P	29.9				32.0	34.1	36.2	38.2	40.2	42.0	43.7	45.3	46.8	48.1			
	A	59.8				62.1	64.4	66.6	68.8	70.8	72.7	74.4	76.0	77.4	78.5			
110	C	177.5				204.5	234.3	267.1	303.1	342.7	386.1	433.5	485.1	541.3	602.3			
	P	28.9				30.9	32.8	34.7	36.4	38.1	39.7	41.2	42.5	43.6	44.6			
	A	58.8				60.9	63.0	65.0	66.9	68.7	70.4	71.9	73.2	74.3	75.3			
100	C	197.7				227.0	259.2	294.7	333.6	376.4	423.1	474.1	529.5	589.8	655.0			
	P	27.8				29.6	31.3	32.9	34.4	35.8	37.1	38.3	39.3	40.2	40.8			
	A	57.5				59.5	61.3	63.1	64.8	66.3	67.7	69.0	70.0	70.9	71.5			
90	C	217.4				248.9	283.5	321.7	363.5	409.4	459.4	513.9	573.2	637.4	706.9			
	P	26.6				28.1	29.5	30.9	32.2	33.3	34.3	35.2	35.9	36.4	36.7			
	A	56.1				57.8	59.4	60.9	62.3	63.6	64.7	65.7	66.4	67.0	67.3			

MODELO BLV

COMPRESOR BITZER

R-449A | 460V

Modelo	Compresor	H.P	TSC (°F)	TSE °F C=Capacidad kBtu's/h P=Potencia kW A= Amps.													
				-5	0	5	10	15	20	25	30	35	40	45			
JLD300BM6C	4PES-15Y	30	130	C	36.5	43.6	51.6	60.6	70.6	81.9	94.5	108.5	124.0	141.0	159.7		
				P	8.4	9.3	10.2	11.0	11.8	12.6	13.3	14.0	14.6	15.2	15.7		
				A	29.1	30.9	32.6	34.4	36.2	37.9	39.6	41.2	42.7	44.1	45.4		
			120	C	43.3	51.2	60.0	70.0	81.1	93.4	107.1	122.3	139.0	157.4	177.5		
				P	8.4	9.2	10.0	10.8	11.5	12.1	12.7	13.3	13.8	14.3	14.7		
				A	29.2	30.7	32.3	33.9	35.4	36.9	38.3	39.6	40.9	42.0	43.0		
		110	C	50.2	58.9	68.6	79.5	91.6	105.0	119.9	136.2	154.1	173.8	195.3			
			P	8.4	9.1	9.8	10.4	11.0	11.6	12.1	12.5	12.9	13.3	13.5			
			A	29.0	30.3	31.7	33.1	34.4	35.6	36.8	37.9	38.8	39.6	40.3			
		100	C	57.3	66.8	77.4	89.2	102.2	116.7	132.7	150.2	169.4	190.3	213.1			
			P	8.2	8.8	9.4	9.9	10.4	10.9	11.3	11.7	11.9	12.2	12.3			
			A	28.6	29.8	31.0	32.1	33.2	34.2	35.1	35.9	36.5	37.0	37.4			
		90	C	64.4	74.7	86.2	98.9	113.0	128.5	145.5	164.2	184.7	206.9	231.1			
			P	7.9	8.4	8.9	9.4	9.8	10.1	10.4	10.6	10.8	10.9	10.9			
			A	28.1	29.1	30.0	30.9	31.8	32.5	33.2	33.7	34.0	34.2	34.2			
		JLD400BM6C	4NES-20Y	40	130	C	46.6	55.0	64.3	74.9	86.8	100.0	114.7	131.0	149.1	169.0	190.8
						P	10.3	11.3	12.3	13.2	14.1	14.9	15.8	16.5	17.2	17.9	18.4
						A	33.6	35.6	37.6	39.6	41.7	43.6	45.5	47.4	49.1	50.7	52.2
120	C				54.4	63.6	74.0	85.6	98.6	113.1	129.1	146.8	166.2	187.6	211.0		
	P				10.2	11.1	12.0	12.8	13.6	14.4	15.0	15.7	16.3	16.8	17.2		
	A				33.5	35.2	37.0	38.8	40.5	42.2	43.8	45.3	46.7	48.0	49.1		
110	C			62.2	72.4	83.8	96.5	110.6	126.2	143.5	162.5	183.4	206.3	231.2			
	P			10.0	10.8	11.6	12.3	13.0	13.6	14.2	14.7	15.2	15.5	15.8			
	A			33.1	34.6	36.2	37.7	39.2	40.6	41.9	43.1	44.2	45.1	45.8			
100	C			70.1	81.2	93.6	107.3	122.6	139.5	158.0	178.4	200.7	225.1	251.6			
	P			9.8	10.5	11.1	11.7	12.3	12.8	13.3	13.6	14.0	14.2	14.3			
	A			32.5	33.8	35.1	36.4	37.6	38.7	39.8	40.6	41.4	41.9	42.3			
90	C			78.1	90.1	103.5	118.3	134.7	152.8	172.6	194.3	218.1	243.9	272.0			
	P			9.4	10.0	10.5	11.0	11.5	11.9	12.2	12.4	12.6	12.7	12.7			
	A			31.7	32.9	33.9	35.0	35.9	36.7	37.5	38.0	38.4	38.6	38.6			
JLD440BM6C	4JE-22Y			44	130	C	52.1	61.7	72.5	84.4	97.7	112.4	128.7	146.7	166.4	188.0	211.7
						P	12.0	13.0	14.1	15.1	16.1	17.0	17.9	18.8	19.6	20.4	21.1
						A	37.1	39.4	41.7	44.0	46.3	48.6	50.9	53.1	55.2	57.2	59.1
		120	C		61.3	71.9	83.7	96.7	111.2	127.2	144.8	164.2	185.4	208.6	233.8		
			P		11.8	12.7	13.7	14.6	15.5	16.3	17.1	17.9	18.6	19.2	19.8		
			A		36.6	38.7	40.8	42.8	44.9	46.9	48.9	50.8	52.6	54.2	55.7		
		110	C	70.4	82.0	94.8	109.0	124.6	141.9	160.8	181.6	204.3	228.9	255.8			
			P	11.5	12.3	13.2	14.0	14.8	15.5	16.2	16.8	17.4	17.9	18.4			
			A	36.0	37.8	39.7	41.5	43.3	45.0	46.7	48.2	49.6	50.9	52.0			
		100	C	79.5	92.0	105.8	121.1	137.9	156.4	176.6	198.8	222.9	249.1	277.5			
			P	11.1	11.9	12.6	13.3	14.0	14.6	15.2	15.7	16.1	16.5	16.8			
			A	35.2	36.7	38.3	39.9	41.4	42.8	44.2	45.4	46.5	47.4	48.1			
		90	C	88.5	101.9	116.8	133.1	151.0	170.7	192.2	215.7	241.2	268.9	298.9			
			P	10.6	11.3	11.9	12.5	13.1	13.5	14.0	14.4	14.7	14.9	15.1			
			A	34.2	35.5	36.9	38.1	39.4	40.5	41.5	42.4	43.1	43.6	44.0			
		JLD500BM6C	4HE-25Y	50	130	C	64.1	75.2	87.6	101.3	116.6	133.5	152.2	172.8	195.5	220.3	247.4
						P	14.8	15.9	17.1	18.2	19.3	20.3	21.4	22.3	23.2	24.1	24.8
						A	46.9	49.4	52.0	54.5	57.1	59.6	62.0	64.4	66.6	68.8	70.7
120	C				74.6	86.8	100.4	115.5	132.2	150.7	171.0	193.3	217.7	244.4	273.4		
	P				14.4	15.4	16.5	17.5	18.5	19.4	20.3	21.2	21.9	22.6	23.3		
	A				46.1	48.3	50.6	52.9	55.2	57.4	59.5	61.5	63.4	65.2	66.8		
110	C			85.0	98.4	113.2	129.6	147.7	167.6	189.5	213.4	239.6	268.1	299.0			
	P			13.9	14.9	15.8	16.7	17.6	18.4	19.2	19.9	20.5	21.1	21.6			
	A			45.1	47.1	49.1	51.1	53.1	55.0	56.8	58.4	60.0	61.3	62.5			
100	C			95.2	109.7	125.7	143.4	162.9	184.2	207.7	233.2	261.1	291.4	324.2			
	P			13.3	14.2	15.0	15.8	16.6	17.3	17.9	18.5	19.0	19.4	19.7			
	A			43.9	45.7	47.4	49.1	50.8	52.4	53.8	55.1	56.3	57.2	58.0			
90	C			105.3	120.9	138.1	157.0	177.8	200.6	225.5	252.7	282.2	314.3	348.9			
	P			12.7	13.5	14.2	14.8	15.4	16.0	16.5	16.9	17.2	17.5	17.6			
	A			42.6	44.1	45.6	47.0	48.3	49.5	50.6	51.6	52.3	52.9	53.3			
JLD600BM6C	4GE-30Y			60	130	C	74.7	87.2	101.2	116.7	134.0	153.1	174.3	197.6	223.2	251.3	282.0
						P	17.1	18.4	19.7	20.9	22.2	23.4	24.5	25.6	26.6	27.5	28.4
						A	55.8	58.6	61.5	64.4	67.2	70.1	72.8	75.5	78.0	80.4	82.6
		120	C		86.6	100.6	116.0	133.1	152.1	173.0	196.1	221.4	249.1	279.4	312.4		
			P		16.6	17.8	19.0	20.1	21.2	22.3	23.3	24.3	25.1	25.9	26.6		
			A		54.8	57.3	59.9	62.5	65.0	67.5	69.9	72.2	74.3	76.3	78.0		
		110	C	98.4	113.7	130.6	149.3	169.9	192.6	217.5	244.8	274.6	307.0	342.3			
			P	16.0	17.1	18.2	19.2	20.2	21.1	22.0	22.8	23.5	24.1	24.6			
			A	53.6	55.8	58.1	60.4	62.6	64.7	66.7	68.6	70.3	71.9	73.2			
		100	C	110.1	126.6	144.9	165.1	187.3	211.7	238.5	267.7	299.5	334.1	371.6			
			P	15.3	16.3	17.2	18.1	19.0	19.8	20.5	21.1	21.7	22.1	22.5			
			A	52.2	54.1	56.1	58.1	59.9	61.7	63.3	64.8	66.1	67.2	68.0			
		90	C	121.4	139.2	158.9	180.6	204.4	230.4	259.0	290.1	323.9	360.6	400.3			
			P	14.6	15.4	16.2	17.0	17.7	18.3	18.9	19.3	19.7	20.0	20.2			
			A	50.6	52.3	54.0	55.6	57.1	58.4	59.7	60.7	61.6	62.2	62.6			

Modelo	Compresor	H.P	TSC (°F)	TSE °F C=Capacidad kBTu's/h P=Potencia kW A= Amps.														
				-5	0	5	10	15	20	25	30	35	40	45				
JLD660BM6C	6JE-33Y	66	130	C	76.7	91.0	107.1	125.0	144.9	167.0	191.5	218.5	248.2	280.7	316.3			
				P	17.8	19.3	20.8	22.3	23.8	25.2	26.5	27.8	29.0	30.1	31.2			
				A	62.1	65.2	68.3	71.5	74.7	77.8	80.9	84.0	86.9	89.6	92.2			
			120	C	90.3	106.0	123.5	143.0	164.7	188.6	214.9	243.9	275.7	310.4	348.2			
				P	17.5	18.9	20.3	21.7	23.0	24.2	25.4	26.5	27.6	28.5	29.4			
				A	61.6	64.4	67.2	70.0	72.9	75.6	78.3	80.9	83.4	85.7	87.7			
			110	C	103.8	121.0	140.0	161.0	184.3	210.0	238.2	269.1	302.9	339.8	379.8			
				P	17.1	18.4	19.6	20.8	22.0	23.1	24.1	25.0	25.9	26.7	27.3			
				A	60.8	63.3	65.8	68.3	70.7	73.1	75.4	77.5	79.5	81.3	82.8			
			100	C	117.3	135.8	156.3	178.9	203.8	231.2	261.2	294.1	329.9	368.8	411.0			
				P	16.6	17.7	18.8	19.9	20.8	21.8	22.6	23.4	24.0	24.6	25.0			
				A	59.7	61.9	64.1	66.2	68.3	70.2	72.1	73.8	75.2	76.5	77.5			
			90	C	130.7	150.5	172.4	196.5	223.0	252.1	284.0	318.7	356.5	397.5	441.8			
				P	15.9	16.9	17.8	18.7	19.5	20.2	20.9	21.5	21.9	22.3	22.5			
				A	58.4	60.3	62.1	63.8	65.5	67.1	68.5	69.7	70.7	71.4	71.9			
			JLD700BM6C	6HE-35Y	70	130	C	94.3	110.7	129.0	149.3	171.8	196.8	224.4	254.7	288.0	324.5	364.3
							P	21.8	23.6	25.4	27.1	28.8	30.4	32.0	33.5	35.0	36.3	37.5
							A	70.5	74.4	78.4	82.4	86.3	90.3	94.1	97.9	101.5	104.9	108.0
120	C	109.8				127.8	147.8	170.0	194.6	221.7	251.5	284.3	320.1	359.2	401.8			
	P	21.3				22.9	24.5	26.1	27.6	29.1	30.5	31.8	33.0	34.1	35.1			
	A	69.4				72.9	76.5	80.1	83.6	87.1	90.4	93.6	96.7	99.4	102.0			
110	C	125.0				144.6	166.4	190.5	217.0	246.2	278.3	313.4	351.8	393.5	438.9			
	P	20.6				22.1	23.5	24.9	26.3	27.6	28.8	29.9	30.9	31.8	32.5			
	A	67.9				71.1	74.3	77.4	80.5	83.4	86.3	88.9	91.4	93.6	95.5			
100	C	140.0				161.3	184.8	210.7	239.2	270.5	304.8	342.3	383.1	427.5	475.6			
	P	19.8				21.1	22.4	23.6	24.8	25.9	26.8	27.7	28.5	29.1	29.7			
	A	66.2				69.0	71.7	74.4	77.0	79.5	81.8	83.9	85.7	87.3	88.5			
90	C	154.9				177.7	202.9	230.6	261.1	294.5	331.0	370.8	414.1	461.1	511.9			
	P	18.9				20.0	21.1	22.1	23.1	24.0	24.7	25.4	25.9	26.3	26.5			
	A	64.3				66.6	68.9	71.1	73.2	75.2	76.9	78.4	79.6	80.5	81.1			
JLD800BM6C	6GE-40Y	80				130	C	109.7	128.1	148.6	171.2	196.3	223.9	254.4	287.9	324.7	364.9	408.7
							P	25.5	27.5	29.4	31.3	33.2	35.0	36.7	38.4	39.9	41.3	42.7
							A	87.3	91.4	95.4	99.5	103.6	107.6	111.5	115.2	118.7	122.1	125.1
			120	C	127.3	147.7	170.1	195.0	222.4	252.6	285.8	322.2	362.0	405.4	452.7			
				P	24.8	26.7	28.4	30.2	31.9	33.5	35.0	36.4	37.8	39.0	40.1			
				A	86.0	89.7	93.4	97.1	100.7	104.2	107.6	110.8	113.9	116.6	119.1			
			110	C	144.5	166.7	191.2	218.2	248.0	280.8	316.7	356.0	398.8	445.5	496.1			
				P	24.0	25.7	27.3	28.8	30.3	31.7	33.1	34.3	35.4	36.3	37.2			
				A	84.4	87.7	91.0	94.2	97.4	100.5	103.3	106.0	108.5	110.6	112.5			
			100	C	161.3	185.3	211.9	241.1	273.3	308.6	347.2	389.4	435.3	485.2	539.2			
				P	23.1	24.6	26.0	27.3	28.6	29.8	30.9	31.9	32.7	33.4	34.0			
				A	82.5	85.4	88.2	91.0	93.7	96.3	98.6	100.8	102.6	104.2	105.4			
			90	C	177.9	203.8	232.3	263.8	298.3	336.2	377.6	422.6	471.6	524.7	582.2			
				P	22.0	23.3	24.5	25.6	26.7	27.6	28.5	29.2	29.8	30.2	30.5			
				A	80.3	82.8	85.2	87.5	89.7	91.8	93.6	95.1	96.4	97.3	97.8			
			JLD1000BM6C	6FE-50Y	100	130	C	135.4	157.9	182.7	210.1	240.3	273.5	310.1	350.2	394.1	442.2	494.5
							P	30.6	32.9	35.3	37.5	39.7	41.9	44.0	46.0	47.8	49.6	51.1
							A	121.2	126.2	131.1	135.9	140.6	145.0	149.2	153.1	156.7	159.9	162.7
120	C	156.7				181.5	208.8	238.9	272.0	308.4	348.4	392.2	440.0	492.1	548.8			
	P	29.9				32.0	34.1	36.2	38.2	40.2	42.0	43.7	45.3	46.8	48.1			
	A	119.6				124.3	128.9	133.3	137.5	141.6	145.4	148.8	152.0	154.7	157.1			
110	C	177.5				204.5	234.3	267.1	303.1	342.7	386.1	433.5	485.1	541.3	602.3			
	P	28.9				30.9	32.8	34.7	36.4	38.1	39.7	41.2	42.5	43.6	44.6			
	A	117.6				121.9	126.0	130.0	133.9	137.5	140.8	143.8	146.4	148.7	150.5			
100	C	197.7				227.0	259.2	294.7	333.6	376.4	423.1	474.1	529.5	589.8	655.0			
	P	27.8				29.6	31.3	32.9	34.4	35.8	37.1	38.3	39.3	40.2	40.8			
	A	115.1				118.9	122.7	126.2	129.6	132.7	135.5	137.9	140.1	141.8	143.0			
90	C	217.4				248.9	283.5	321.7	363.5	409.4	459.4	513.9	573.2	637.4	706.9			
	P	26.6				28.1	29.5	30.9	32.2	33.3	34.3	35.2	35.9	36.4	36.7			
	A	112.2				115.5	118.8	121.8	124.6	127.2	129.4	131.3	132.8	133.9	134.6			

MODELO BLV

COMPRESOR BITZER

R-449A | 230V

Modelo	Compresor	H.P	TSC (°F)	TSE °F C=Capacidad kBTu's/h P=Potencia kW A= Amps.													
				-45	-40	-35	-30	-25	-20	-15	-10	-5	0				
JLD300BL6D	4JE-15Y	30	130	C	6.3	10.5	15.1	20.1	25.7	32.0	39.0	46.8	55.6	65.5			
				P	4.2	5.1	6.0	7.0	8.0	9.0	10.1	11.1	12.2	13.2			
				A	11.9	12.4	13.0	13.8	14.6	15.5	16.5	17.6	18.7	19.9			
			120	C	9.8	14.5	19.6	25.2	31.5	38.4	46.2	54.9	64.6	75.4			
				P	4.5	5.3	6.2	7.1	8.0	9.0	10.0	11.0	11.9	12.9			
				A	12.1	12.6	13.2	13.9	14.7	15.6	16.5	17.5	18.5	19.5			
			110	C	13.5	18.6	24.2	30.4	37.3	45.0	53.5	63.0	73.6	85.3			
				P	4.7	5.5	6.3	7.2	8.1	8.9	9.8	10.7	11.6	12.5			
				A	12.3	12.8	13.4	14.0	14.7	15.5	16.3	17.2	18.1	19.1			
			100	C	17.2	22.8	28.9	35.7	43.2	51.5	60.8	71.1	82.5	95.2			
				P	4.9	5.6	6.4	7.2	8.0	8.8	9.6	10.4	11.2	12.0			
				A	12.5	12.9	13.4	14.0	14.7	15.4	16.1	16.9	17.7	18.5			
				C	49.6	58.6	68.7	80.1	92.8	106.9	122.6	139.9	159.0	179.8			
				P	5.2	5.0	4.9	4.6	4.4	4.1	3.7	3.3	2.8	2.3			
				A	13.3	13.2	13.0	12.8	12.6	12.3	11.9	11.5	11.0	10.4			
			JLD360BL6D	4HE-18Y	36	130	C	9.8	14.7	20.0	25.9	32.3	39.5	47.6	56.6	66.7	78.0
							P	6.0	6.9	7.9	9.0	10.2	11.3	12.5	13.7	14.9	16.2
							A	13.0	13.7	14.5	15.5	16.6	17.8	19.1	20.4	21.9	23.3
120	C	13.6				19.1	25.0	31.5	38.8	46.8	55.8	65.8	77.0	89.4			
	P	6.1				7.0	8.0	9.0	10.1	11.2	12.3	13.4	14.5	15.7			
	A	13.1				13.8	14.6	15.5	16.5	17.7	18.8	20.1	21.4	22.7			
110	C	17.6				23.6	30.2	37.4	45.3	54.2	64.1	75.1	87.3	100.8			
	P	6.2				7.1	8.0	8.9	9.9	11.0	12.0	13.0	14.0	15.1			
	A	13.3				13.9	14.6	15.5	16.4	17.4	18.5	19.6	20.8	22.0			
100	C	21.8				28.3	35.4	43.2	51.9	61.6	72.3	84.3	97.5	112.1			
	P	6.3				7.1	7.9	8.8	9.8	10.7	11.6	12.6	13.5	14.4			
	A	13.4				13.9	14.6	15.4	16.2	17.2	18.1	19.1	20.1	21.2			
90	C	26.0				32.9	40.6	49.1	58.5	68.9	80.5	93.3	107.5	123.2			
	P	6.3				7.1	7.9	8.7	9.5	10.4	11.2	12.0	12.8	13.6			
	A	13.4				13.9	14.6	15.3	16.0	16.8	17.7	18.5	19.4	20.3			
JLD460BL6D	4GE-28Y	46				130	C	14.5	20.1	26.2	32.8	40.2	48.4	57.5	67.8	79.2	92.0
							P	7.8	8.9	10.0	11.2	12.5	13.8	15.2	16.6	18.0	19.5
							A	14.4	15.3	16.4	17.7	19.1	20.6	22.2	23.9	25.6	27.4
			120	C	18.5	24.8	31.6	39.1	47.3	56.5	66.7	78.2	90.9	105.1			
				P	7.8	8.8	9.9	11.1	12.3	13.5	14.8	16.1	17.4	18.7			
				A	14.5	15.3	16.4	17.5	18.8	20.2	21.7	23.2	24.8	26.5			
			110	C	22.8	29.7	37.2	45.4	54.6	64.7	76.0	88.6	102.5	118.0			
				P	7.8	8.7	9.8	10.9	12.0	13.1	14.3	15.5	16.7	17.9			
				A	14.5	15.3	16.2	17.3	18.5	19.8	21.1	22.5	24.0	25.4			
			100	C	27.2	34.7	42.9	51.9	61.8	72.9	85.2	98.9	114.0	130.8			
				P	7.8	8.7	9.6	10.6	11.7	12.7	13.8	14.9	15.9	17.0			
				A	14.5	15.2	16.1	17.1	18.2	19.3	20.5	21.8	23.0	24.3			
			90	C	31.7	39.7	48.5	58.3	69.0	81.0	94.3	109.0	125.3	143.2			
				P	7.7	8.6	9.4	10.4	11.3	12.2	13.2	14.2	15.1	16.0			
				A	14.5	15.1	15.9	16.8	17.8	18.8	19.8	20.9	22.0	23.1			
			JLD560BL6D	4FE-28Y	56	130	C	12.5	20.3	28.6	37.4	46.9	57.2	68.6	81.1	95.0	110.3
							P	9.3	10.6	11.9	13.3	14.8	16.4	17.9	19.5	21.2	22.8
							A	20.6	21.6	22.8	24.1	25.5	27.1	28.8	30.6	32.4	34.4
120	C	19.2				27.5	36.3	45.8	56.1	67.5	79.9	93.7	108.9	125.7			
	P	9.3				10.5	11.8	13.1	14.5	16.0	17.5	19.0	20.5	22.0			
	A	20.7				21.6	22.7	23.9	25.3	26.7	28.3	30.0	31.6	33.4			
110	C	25.8				34.5	43.9	54.1	65.3	77.5	91.1	106.1	122.6	140.8			
	P	9.2				10.4	11.6	12.9	14.2	15.6	16.9	18.3	19.7	21.0			
	A	20.7				21.6	22.6	23.7	25.0	26.3	27.7	29.2	30.8	32.3			
100	C	32.2				41.3	51.3	62.2	74.1	87.4	102.0	118.1	136.0	155.7			
	P	9.2				10.3	11.4	12.6	13.8	15.1	16.3	17.6	18.8	20.0			
	A	20.7				21.5	22.4	23.5	24.6	25.8	27.1	28.4	29.8	31.1			
90	C	38.4				48.0	58.5	70.0	82.8	96.9	112.6	129.9	149.0	170.2			
	P	9.2				10.2	11.2	12.3	13.4	14.5	15.7	16.8	17.8	18.9			
	A	20.7				21.4	22.2	23.2	24.2	25.3	26.4	27.5	28.7	29.9			

Modelo	Compresor	H.P	TSC (°F)	TSE °F C=Capacidad kBtu's/h P=Potencia kW A= Amps.												
				-45	-40	-35	-30	-25	-20	-15	-10	-5	0			
JLD680BL6D	6GE-34Y	68	130	C	20.1	29.4	39.2	49.7	61.2	73.8	87.7	103.2	120.3	139.2		
				P	10.8	12.4	14.1	15.9	17.8	19.8	21.9	24.0	26.2	28.3		
				A	21.7	23.1	24.7	26.6	28.7	30.9	33.3	35.9	38.5	41.2		
			120	C	28.3	38.1	48.7	60.2	72.7	86.6	101.8	118.8	137.5	158.3		
				P	10.9	12.4	14.1	15.8	17.6	19.5	21.4	23.4	25.4	27.4		
				A	21.9	23.2	24.8	26.5	28.5	30.6	32.8	35.2	37.6	40.0		
			110	C	35.9	46.4	57.7	70.1	83.8	98.8	115.4	133.9	154.3	176.9		
				P	11.0	12.5	14.0	15.6	17.3	19.1	20.9	22.7	24.5	26.3		
				A	22.0	23.3	24.7	26.4	28.2	30.1	32.2	34.3	36.4	38.6		
			100	C	43.2	54.3	66.4	79.7	94.4	110.6	128.6	148.6	170.7	195.0		
				P	11.1	12.4	13.9	15.4	17.0	18.6	20.2	21.8	23.5	25.1		
				A	22.1	23.3	24.6	26.1	27.8	29.5	31.4	33.3	35.2	37.1		
		90	C	50.3	62.0	74.8	89.0	104.8	122.2	141.6	163.0	186.8	213.0			
			P	11.1	12.4	13.7	15.1	16.5	18.0	19.4	20.9	22.3	23.7			
			A	22.1	23.2	24.4	25.8	27.3	28.8	30.4	32.1	33.8	35.4			
		JLD880BL6D	6FE-44Y	88	130	C	18.8	30.5	42.8	56.0	70.3	85.8	102.9	121.7	142.5	165.4
						P	14.6	16.4	18.4	20.4	22.6	24.8	27.2	29.5	31.9	34.4
						A	33.6	35.1	36.7	38.6	40.7	43.0	45.4	47.9	50.5	53.1
					120	C	28.8	41.2	54.4	68.7	84.2	101.2	119.9	140.6	163.4	188.5
						P	14.5	16.3	18.2	20.1	22.2	24.3	26.5	28.7	30.9	33.2
						A	33.6	35.0	36.6	38.4	40.3	42.5	44.7	47.0	49.4	51.8
					110	C	38.7	51.7	65.8	81.1	97.9	116.3	136.6	159.1	183.9	211.3
						P	14.5	16.1	17.9	19.8	21.7	23.7	25.7	27.8	29.8	31.8
						A	33.6	34.9	36.4	38.1	39.9	41.8	43.9	46.0	48.2	50.3
100	C				48.3	62.0	76.9	93.2	111.2	131.0	153.0	177.2	204.0	233.5		
	P				14.4	15.9	17.6	19.3	21.1	23.0	24.8	26.7	28.5	30.3		
	A				33.6	34.8	36.1	37.7	39.3	41.1	42.9	44.8	46.8	48.7		
90	C			57.6	72.0	87.7	105.0	124.1	145.3	168.8	194.8	223.5	255.2			
	P			14.3	15.7	17.3	18.9	20.5	22.1	23.8	25.5	27.1	28.6			
	A			33.5	34.6	35.8	37.2	38.7	40.3	41.9	43.6	45.3	46.9			

MODELO BLV

COMPRESOR BITZER

R-449A | 460V

Modelo	Compresor	H.P	TSC (°F)	TSE °F C=Capacidad kBtu's/h P=Potencia kW A= Amps.												
				-45	-40	-35	-30	-25	-20	-15	-10	-5	0			
JLD300BL6C	4JE-15Y	30	130	C	6.3	10.5	15.1	20.1	25.7	32.0	39.0	46.8	55.6	65.5		
				P	4.2	5.1	6.0	7.0	8.0	9.0	10.1	11.1	12.2	13.2		
				A	23.8	24.8	26.1	27.6	29.2	31.1	33.1	35.2	37.4	39.7		
			120	C	9.8	14.5	19.6	25.2	31.5	38.4	46.2	54.9	64.6	75.4		
				P	4.5	5.3	6.2	7.1	8.0	9.0	10.0	11.0	11.9	12.9		
				A	24.3	25.3	26.5	27.9	29.4	31.1	33.0	34.9	36.9	39.0		
		110	C	13.5	18.6	24.2	30.4	37.3	45.0	53.5	63.0	73.6	85.3			
			P	4.7	5.5	6.3	7.2	8.1	8.9	9.8	10.7	11.6	12.5			
			A	24.7	25.6	26.7	28.0	29.4	31.0	32.7	34.4	36.3	38.1			
		100	C	17.2	22.8	28.9	35.7	43.2	51.5	60.8	71.1	82.5	95.2			
			P	4.9	5.6	6.4	7.2	8.0	8.8	9.6	10.4	11.2	12.0			
			A	25.0	25.8	26.8	28.0	29.3	30.8	32.3	33.8	35.4	37.1			
		90	C	21.0	27.0	33.7	41.0	49.1	58.1	68.1	79.1	91.4	105.0			
			P	5.1	5.7	6.4	7.2	7.9	8.6	9.3	10.1	10.8	11.4			
			A	25.2	26.0	26.9	28.0	29.1	30.4	31.7	33.1	34.4	35.8			
		JLD360BL6C	4HE-18Y	36	130	C	9.8	14.7	20.0	25.9	32.3	39.5	47.6	56.6	66.7	78.0
						P	6.0	6.9	7.9	9.0	10.2	11.3	12.5	13.7	14.9	16.2
						A	25.9	27.4	29.1	31.0	33.2	35.6	38.2	40.9	43.7	46.6
120	C				13.6	19.1	25.0	31.5	38.8	46.8	55.8	65.8	77.0	89.4		
	P				6.1	7.0	8.0	9.0	10.1	11.2	12.3	13.4	14.5	15.7		
	A				26.3	27.6	29.2	31.1	33.1	35.3	37.7	40.2	42.7	45.4		
110	C			17.6	23.6	30.2	37.4	45.3	54.2	64.1	75.1	87.3	100.8			
	P			6.2	7.1	8.0	8.9	9.9	11.0	12.0	13.0	14.0	15.1			
	A			26.5	27.8	29.3	31.0	32.9	34.9	37.0	39.3	41.6	44.0			
100	C			21.8	28.3	35.4	43.2	51.9	61.6	72.3	84.3	97.5	112.1			
	P			6.3	7.1	7.9	8.8	9.8	10.7	11.6	12.6	13.5	14.4			
	A			26.7	27.9	29.2	30.8	32.5	34.3	36.2	38.2	40.3	42.4			
90	C			26.0	32.9	40.6	49.1	58.5	68.9	80.5	93.3	107.5	123.2			
	P			6.3	7.1	7.9	8.7	9.5	10.4	11.2	12.0	12.8	13.6			
	A			26.8	27.9	29.1	30.5	32.0	33.6	35.3	37.1	38.8	40.6			
JLD460BL6C	4GE-28Y			46	130	C	14.5	20.1	26.2	32.8	40.2	48.4	57.5	67.8	79.2	92.0
						P	7.8	8.9	10.0	11.2	12.5	13.8	15.2	16.6	18.0	19.5
						A	28.8	30.7	32.9	35.4	38.1	41.1	44.3	47.7	51.2	54.9
		120	C		18.5	24.8	31.6	39.1	47.3	56.5	66.7	78.2	90.9	105.1		
			P		7.8	8.8	9.9	11.1	12.3	13.5	14.8	16.1	17.4	18.7		
			A		28.9	30.7	32.7	35.1	37.6	40.4	43.4	46.5	49.7	53.0		
		110	C	22.8	29.7	37.2	45.4	54.6	64.7	76.0	88.6	102.5	118.0			
			P	7.8	8.7	9.8	10.9	12.0	13.1	14.3	15.5	16.7	17.9			
			A	29.0	30.6	32.5	34.6	37.0	39.6	42.3	45.1	48.0	50.9			
		100	C	27.2	34.7	42.9	51.9	61.8	72.9	85.2	98.9	114.0	130.8			
			P	7.8	8.7	9.6	10.6	11.7	12.7	13.8	14.9	15.9	17.0			
			A	29.0	30.4	32.2	34.2	36.3	38.6	41.0	43.5	46.1	48.6			
		90	C	31.7	39.7	48.5	58.3	69.0	81.0	94.3	109.0	125.3	143.2			
			P	7.7	8.6	9.4	10.4	11.3	12.2	13.2	14.2	15.1	16.0			
			A	28.9	30.3	31.8	33.6	35.5	37.6	39.7	41.9	44.0	46.2			
		JLD560BL6C	4FE-28Y	56	130	C	12.5	20.3	28.6	37.4	46.9	57.2	68.6	81.1	95.0	110.3
						P	9.3	10.6	11.9	13.3	14.8	16.4	17.9	19.5	21.2	22.8
						A	41.3	43.2	45.5	48.1	51.1	54.2	57.6	61.2	64.9	68.7
120	C				19.2	27.5	36.3	45.8	56.1	67.5	79.9	93.7	108.9	125.7		
	P				9.3	10.5	11.8	13.1	14.5	16.0	17.5	19.0	20.5	22.0		
	A				41.4	43.2	45.4	47.8	50.6	53.5	56.6	59.9	63.3	66.8		
110	C			25.8	34.5	43.9	54.1	65.3	77.5	91.1	106.1	122.6	140.8			
	P			9.2	10.4	11.6	12.9	14.2	15.6	16.9	18.3	19.7	21.0			
	A			41.4	43.1	45.1	47.4	49.9	52.6	55.5	58.5	61.5	64.6			
100	C			32.2	41.3	51.3	62.2	74.1	87.4	102.0	118.1	136.0	155.7			
	P			9.2	10.3	11.4	12.6	13.8	15.1	16.3	17.6	18.8	20.0			
	A			41.4	43.0	44.8	46.9	49.2	51.6	54.2	56.8	59.5	62.3			
90	C			38.4	48.0	58.5	70.0	82.8	96.9	112.6	129.9	149.0	170.2			
	P			9.2	10.2	11.2	12.3	13.4	14.5	15.7	16.8	17.8	18.9			
	A			41.4	42.8	44.5	46.3	48.4	50.5	52.8	55.1	57.4	59.7			

Modelo	Compresor	H.P	TSC (°F)	TSE °F C=Capacidad kBtu's/h P=Potencia kW A= Amps.												
				-45	-40	-35	-30	-25	-20	-15	-10	-5	0			
JLD680BL6C	6GE-34Y	68	130	C	20.1	29.4	39.2	49.7	61.2	73.8	87.7	103.2	120.3	139.2		
				P	10.8	12.4	14.1	15.9	17.8	19.8	21.9	24.0	26.2	28.3		
				A	43.3	46.1	49.5	53.2	57.4	61.9	66.7	71.7	77.0	82.3		
			120	C	28.3	38.1	48.7	60.2	72.7	86.6	101.8	118.8	137.5	158.3		
				P	10.9	12.4	14.1	15.8	17.6	19.5	21.4	23.4	25.4	27.4		
				A	43.7	46.4	49.5	53.1	57.0	61.2	65.6	70.3	75.1	80.0		
			110	C	35.9	46.4	57.7	70.1	83.8	98.8	115.4	133.9	154.3	176.9		
				P	11.0	12.5	14.0	15.6	17.3	19.1	20.9	22.7	24.5	26.3		
				A	44.0	46.5	49.5	52.8	56.4	60.2	64.3	68.6	72.9	77.3		
			100	C	43.2	54.3	66.4	79.7	94.4	110.6	128.6	148.6	170.7	195.0		
				P	11.1	12.4	13.9	15.4	17.0	18.6	20.2	21.8	23.5	25.1		
				A	44.2	46.5	49.2	52.2	55.5	59.0	62.7	66.5	70.4	74.2		
		90	C	50.3	62.0	74.8	89.0	104.8	122.2	141.6	163.0	186.8	213.0			
			P	11.1	12.4	13.7	15.1	16.5	18.0	19.4	20.9	22.3	23.7			
			A	44.3	46.4	48.8	51.6	54.5	57.6	60.9	64.2	67.5	70.9			
		JLD880BL6C	6FE-44Y	88	130	C	18.8	30.5	42.8	56.0	70.3	85.8	102.9	121.7	142.5	165.4
						P	14.6	16.4	18.4	20.4	22.6	24.8	27.2	29.5	31.9	34.4
						A	67.3	70.1	73.5	77.3	81.4	85.9	90.7	95.7	100.9	106.3
					120	C	28.8	41.2	54.4	68.7	84.2	101.2	119.9	140.6	163.4	188.5
						P	14.5	16.3	18.2	20.1	22.2	24.3	26.5	28.7	30.9	33.2
						A	67.3	70.0	73.2	76.8	80.7	84.9	89.4	94.0	98.8	103.6
					110	C	38.7	51.7	65.8	81.1	97.9	116.3	136.6	159.1	183.9	211.3
						P	14.5	16.1	17.9	19.8	21.7	23.7	25.7	27.8	29.8	31.8
						A	67.2	69.8	72.8	76.1	79.8	83.7	87.7	92.0	96.3	100.7
100	C				48.3	62.0	76.9	93.2	111.2	131.0	153.0	177.2	204.0	233.5		
	P				14.4	15.9	17.6	19.3	21.1	23.0	24.8	26.7	28.5	30.3		
	A				67.1	69.5	72.3	75.3	78.7	82.2	85.9	89.7	93.6	97.4		
90	C			57.6	72.0	87.7	105.0	124.1	145.3	168.8	194.8	223.5	255.2			
	P			14.3	15.7	17.3	18.9	20.5	22.1	23.8	25.5	27.1	28.6			
	A			67.0	69.2	71.7	74.5	77.4	80.6	83.9	87.2	90.5	93.8			

MODELO BLV

COMPRESOR BITZER

R-449A | 230V

Modelo	Compresor	H.P	TSC (°F)	TSE °F C=Capacidad kBtu's/h P=Potencia kW A= Amps.													
				-5	0	5	10	15	20	25	30	35	40	45			
JLD300BM6D	4PES-15Y	30	130	C	35.7	42.2	49.6	58.1	67.5	78.2	90.0	103.2	117.8	133.8	151.5		
				P	9.7	10.6	11.5	12.4	13.2	14.1	14.9	15.7	16.4	17.1	17.8		
				A	15.9	16.8	17.8	18.7	19.7	20.7	21.7	22.7	23.7	24.6	25.5		
			120	C	43.7	51.3	59.9	69.4	80.2	92.1	105.3	119.9	136.0	153.6	172.9		
				P	9.6	10.4	11.2	12.0	12.8	13.5	14.2	14.9	15.6	16.1	16.7		
				A	15.7	16.6	17.4	18.3	19.2	20.1	20.9	21.8	22.6	23.3	24.0		
			110	C	52.0	60.6	70.2	80.9	92.9	106.1	120.6	136.7	154.2	173.4	194.3		
				P	9.4	10.1	10.9	11.6	12.2	12.9	13.5	14.1	14.6	15.1	15.5		
				A	15.5	16.3	17.1	17.8	18.6	19.3	20.1	20.7	21.4	22.0	22.5		
		100	C	60.4	70.0	80.7	92.5	105.6	120.1	136.0	153.5	172.5	193.2	215.7			
			P	9.2	9.8	10.5	11.1	11.6	12.2	12.7	13.1	13.5	13.9	14.1			
			A	15.3	15.9	16.6	17.3	17.9	18.5	19.1	19.6	20.1	20.5	20.9			
		90	C	69.0	79.5	91.3	104.2	118.5	134.3	151.5	170.3	190.8	213.0	237.1			
			P	8.9	9.4	10.0	10.5	11.0	11.4	11.8	12.1	12.4	12.6	12.7			
			A	15.0	15.5	16.1	16.7	17.2	17.7	18.1	18.5	18.8	19.0	19.1			
		JLD400BM6D	4NES-20Y	40	130	C	44.8	52.6	61.4	71.3	82.4	94.8	108.7	124.1	141.1	159.9	180.4
						P	12.2	13.1	14.1	15.1	16.1	17.0	17.9	18.8	19.6	20.4	21.2
						A	18.7	19.8	20.9	22.0	23.2	24.3	25.4	26.6	27.6	28.7	29.7
120	C				54.3	63.2	73.2	84.5	97.0	111.0	126.4	143.5	162.2	182.7	205.2		
	P				11.9	12.8	13.6	14.5	15.4	16.2	17.0	17.8	18.5	19.1	19.7		
	A				18.4	19.4	20.3	21.3	22.3	23.3	24.3	25.3	26.2	27.0	27.8		
110	C				63.8	73.9	85.2	97.7	111.6	127.1	144.1	162.7	183.2	205.5	229.8		
	P				11.5	12.3	13.1	13.9	14.7	15.4	16.1	16.7	17.3	17.8	18.2		
	A				18.0	18.9	19.7	20.6	21.5	22.3	23.1	23.9	24.6	25.3	25.9		
100	C			73.5	84.7	97.2	111.0	126.3	143.2	161.7	182.0	204.1	228.2	254.4			
	P			11.1	11.8	12.5	13.2	13.9	14.5	15.0	15.5	15.9	16.3	16.6			
	A			17.6	18.3	19.1	19.8	20.6	21.3	21.9	22.5	23.0	23.5	23.8			
90	C			83.3	95.6	109.3	124.4	141.1	159.4	179.4	201.3	225.1	250.9	278.9			
	P			10.6	11.3	11.9	12.5	13.0	13.5	13.9	14.2	14.5	14.7	14.8			
	A			17.1	17.8	18.4	19.0	19.6	20.1	20.6	21.0	21.4	21.6	21.8			
JLD440BM6D	4JE-22Y			44	130	C	50.5	59.3	69.2	80.3	92.7	106.5	121.8	138.7	157.2	177.6	199.8
						P	13.4	14.5	15.6	16.7	17.7	18.8	19.8	20.8	21.7	22.6	23.5
						A	20.1	21.3	22.6	23.9	25.2	26.5	27.8	29.1	30.4	31.6	32.7
		120	C		61.4	71.5	82.8	95.3	109.2	124.6	141.6	160.2	180.6	202.8	227.0		
			P		13.2	14.2	15.2	16.2	17.1	18.0	18.9	19.8	20.6	21.3	22.0		
			A		19.9	21.0	22.1	23.3	24.4	25.6	26.7	27.8	28.8	29.8	30.8		
		110	C		72.3	83.7	96.3	110.2	125.6	142.5	161.1	181.4	203.6	227.7	253.8		
			P		12.9	13.8	14.7	15.6	16.4	17.2	17.9	18.6	19.2	19.8	20.3		
			A		19.5	20.5	21.5	22.5	23.5	24.5	25.4	26.3	27.1	27.9	28.6		
		100	C	83.3	95.9	109.7	125.0	141.8	160.3	180.4	202.4	226.3	252.2	280.3			
			P	12.6	13.3	14.1	14.8	15.5	16.1	16.7	17.3	17.8	18.2	18.6			
			A	19.1	20.0	20.8	21.7	22.5	23.3	24.0	24.7	25.3	25.9	26.3			
		90	C	94.3	108.0	123.1	139.7	157.9	177.8	199.5	223.1	248.7	276.4	306.2			
			P	12.0	12.7	13.3	13.9	14.5	15.0	15.5	15.8	16.2	16.4	16.6			
			A	18.5	19.3	20.0	20.7	21.3	21.9	22.5	22.9	23.3	23.7	23.9			
		JLD500BM6D	4HE-25Y	50	130	C	61.4	71.6	83.0	95.8	110.1	126.0	143.6	163.0	184.3	207.7	233.3
						P	16.2	17.5	18.7	19.9	21.1	22.3	23.4	24.6	25.6	26.6	27.6
						A	25.0	26.4	27.8	29.3	30.7	32.2	33.6	35.0	36.4	37.7	39.0
120	C				74.1	85.8	98.8	113.3	129.4	147.1	166.7	188.1	211.6	237.3	265.2		
	P				15.9	17.1	18.2	19.3	20.4	21.4	22.4	23.4	24.3	25.1	25.9		
	A				24.7	25.9	27.2	28.5	29.8	31.1	32.3	33.5	34.6	35.7	36.8		
110	C				86.7	99.9	114.5	130.6	148.4	168.0	189.4	212.9	238.5	266.3	296.5		
	P				15.5	16.5	17.5	18.5	19.5	20.4	21.2	22.0	22.8	23.4	24.1		
	A				24.2	25.4	26.5	27.6	28.7	29.8	30.8	31.8	32.8	33.6	34.4		
100	C			99.3	113.9	130.0	147.7	167.2	188.5	211.8	237.3	264.9	294.9	327.3			
	P			15.0	15.9	16.8	17.6	18.4	19.2	19.9	20.5	21.1	21.6	22.0			
	A			23.6	24.6	25.6	26.6	27.5	28.4	29.2	30.0	30.7	31.3	31.9			
90	C			111.8	127.7	145.3	164.5	185.6	208.7	233.8	261.1	290.8	322.8	357.4			
	P			14.4	15.1	15.9	16.6	17.2	17.8	18.4	18.9	19.3	19.6	19.8			
	A			23.0	23.8	24.6	25.4	26.2	26.9	27.5	28.0	28.5	28.9	29.2			
JLD600BM6D	4GE-30Y			60	130	C	71.1	82.7	95.6	110.1	126.3	144.2	164.1	186.1	210.3	236.8	265.7
						P	18.8	20.2	21.6	23.0	24.4	25.7	27.0	28.3	29.5	30.7	31.8
						A	29.8	31.4	33.0	34.6	36.2	37.9	39.5	41.1	42.6	44.1	45.6
		120	C		85.7	99.0	113.9	130.3	148.6	168.7	191.0	215.4	242.1	271.2	302.9		
			P		18.4	19.7	21.0	22.3	23.5	24.7	25.9	27.0	28.0	29.0	29.9		
			A		29.4	30.8	32.3	33.7	35.2	36.6	38.1	39.4	40.8	42.0	43.2		
		110	C		100.3	115.3	131.9	150.3	170.6	192.9	217.3	244.1	273.3	305.0	339.4		
			P		18.0	19.1	20.3	21.4	22.5	23.5	24.5	25.5	26.3	27.2	27.9		
			A		28.8	30.1	31.4	32.7	34.0	35.2	36.5	37.6	38.7	39.7	40.6		
		100	C	114.7	131.3	149.7	169.9	192.1	216.5	243.2	272.2	303.8	338.0	375.1			
			P	17.3	18.4	19.4	20.4	21.3	22.2	23.0	23.8	24.5	25.1	25.6			
			A	28.1	29.3	30.4	31.5	32.6	33.7	34.7	35.6	36.4	37.2	37.8			
		90	C	128.9	147.1	167.1	189.1	213.3	239.7	268.4	299.7	333.6	370.3	409.9			
			P	16.6	17.5	18.4	19.2	20.0	20.7	21.3	21.9	22.4	22.8	23.2			
			A	27.3	28.3	29.3	30.2	31.1	31.9	32.7	33.4	34.0	34.5	34.8			

Modelo	Compresor	H.P	TSC (°F)	TSE °F C=Capacidad kBTu's/h P=Potencia kW A= Amps.												
				-5	0	5	10	15	20	25	30	35	40	45		
JLD660BM6D	6JE-33Y	66	130	C	74.5	87.7	102.5	119.2	137.8	158.5	181.5	206.8	234.7	265.3	298.8	
				P	19.8	21.4	23.0	24.5	26.0	27.5	28.9	30.2	31.4	32.6	33.6	
				A	33.1	34.8	36.5	38.2	39.9	41.6	43.2	44.8	46.4	47.8	49.2	
			120	C	90.6	105.7	122.5	141.2	162.0	185.0	210.3	238.1	268.6	301.9	338.2	
				P	19.6	21.0	22.5	23.8	25.2	26.4	27.6	28.8	29.8	30.7	31.5	
				A	32.8	34.3	35.8	37.4	38.9	40.3	41.8	43.1	44.4	45.6	46.6	
		110	C	106.8	123.6	142.3	163.1	185.9	211.1	238.8	269.1	302.1	338.0	377.0		
			P	19.2	20.5	21.7	22.9	24.1	25.2	26.2	27.1	27.9	28.7	29.3		
			A	32.4	33.7	35.0	36.4	37.7	38.9	40.1	41.2	42.2	43.1	43.8		
		100	C	123.0	141.6	162.1	184.8	209.7	237.0	267.0	299.6	335.1	373.6	415.2		
			P	18.6	19.7	20.8	21.9	22.8	23.7	24.6	25.3	25.9	26.4	26.8		
			A	31.8	32.9	34.1	35.2	36.3	37.3	38.2	39.1	39.8	40.4	40.8		
	90	C	139.2	159.4	181.7	206.3	233.2	262.6	294.7	329.7	367.5	408.6	452.8			
		P	17.8	18.8	19.7	20.6	21.4	22.1	22.7	23.2	23.6	23.9	24.0			
		A	31.0	32.0	33.0	33.9	34.8	35.5	36.2	36.8	37.2	37.5	37.7			
	JLD700BM6D	6HE-35Y	70	130	C	90.4	105.5	122.3	141.2	162.2	185.6	211.5	240.0	271.4	305.7	343.3
					P	24.5	26.4	28.2	29.9	31.7	33.3	34.9	36.5	37.9	39.3	40.5
					A	38.2	40.3	42.4	44.5	46.6	48.7	50.7	52.6	54.5	56.2	57.8
				120	C	109.0	126.2	145.4	166.7	190.3	216.3	245.0	276.5	311.0	348.6	389.6
					P	24.0	25.7	27.3	28.9	30.4	31.9	33.3	34.6	35.8	37.0	38.0
					A	37.6	39.5	41.4	43.3	45.1	46.9	48.7	50.3	51.9	53.3	54.6
			110	C	127.5	146.8	168.2	191.9	218.0	246.7	278.2	312.6	350.1	390.9	435.1	
				P	23.3	24.8	26.3	27.7	29.0	30.3	31.4	32.5	33.5	34.4	35.2	
				A	36.8	38.5	40.2	41.8	43.4	45.0	46.4	47.8	49.0	50.1	51.1	
100			C	146.0	167.3	190.9	216.8	245.4	276.7	310.8	348.1	388.6	432.5	480.0		
			P	22.4	23.8	25.0	26.2	27.4	28.4	29.4	30.3	31.0	31.7	32.2		
			A	35.8	37.3	38.8	40.2	41.5	42.8	44.0	45.0	46.0	46.8	47.4		
90		C	164.4	187.7	213.3	241.6	272.5	306.3	343.1	383.2	426.6	473.6	524.3			
		P	21.4	22.5	23.6	24.6	25.6	26.4	27.2	27.8	28.3	28.7	29.0			
		A	34.7	36.0	37.2	38.3	39.4	40.4	41.3	42.1	42.7	43.2	43.5			
JLD800BM6D		6GE-40Y	80	130	C	104.4	121.3	140.1	161.0	184.3	210.2	238.8	270.3	304.9	342.8	384.1
					P	28.6	30.7	32.7	34.7	36.7	38.6	40.4	42.2	43.8	45.4	46.9
					A	46.9	49.1	51.3	53.5	55.7	57.8	59.9	61.9	63.9	65.7	67.5
				120	C	125.7	145.0	166.4	190.2	216.5	245.6	277.5	312.5	350.9	392.6	438.0
					P	28.0	29.9	31.7	33.5	35.3	36.9	38.5	40.1	41.5	42.8	44.0
					A	46.2	48.2	50.2	52.1	54.1	56.0	57.8	59.6	61.2	62.8	64.2
		110	C	146.6	168.4	192.4	219.0	248.3	280.4	315.7	354.2	396.2	441.8	491.2		
			P	27.2	28.9	30.5	32.1	33.6	35.1	36.5	37.7	38.9	40.0	41.0		
			A	45.3	47.1	48.9	50.6	52.3	53.9	55.5	57.0	58.3	59.5	60.6		
	100	C	167.5	191.6	218.2	247.5	279.7	314.9	353.4	395.4	441.0	490.4	543.8			
		P	26.1	27.6	29.1	30.5	31.8	33.0	34.2	35.2	36.2	37.0	37.7			
		A	44.2	45.8	47.3	48.9	50.3	51.7	53.0	54.2	55.2	56.1	56.9			
90	C	188.3	214.7	243.9	275.9	310.9	349.2	390.9	436.2	485.4	538.5	595.8				
	P	25.0	26.3	27.5	28.7	29.8	30.8	31.7	32.6	33.3	33.8	34.3				
	A	43.0	44.4	45.7	47.0	48.2	49.3	50.3	51.2	52.0	52.6	53.0				
JLD1000BM6D	6FE-50Y	100	130	C	128.6	149.1	171.8	197.1	225.2	256.3	290.6	328.4	369.8	415.2	464.6	
				P	34.7	37.3	39.9	42.5	45.0	47.4	49.7	52.0	54.1	56.1	58.0	
				A	64.9	67.7	70.4	73.0	75.5	77.9	80.1	82.2	84.1	85.8	87.3	
			120	C	154.5	177.9	204.0	232.8	264.6	299.6	338.1	380.3	426.3	476.5	531.1	
				P	34.2	36.6	38.9	41.2	43.5	45.6	47.7	49.6	51.4	53.1	54.6	
				A	64.4	66.9	69.4	71.8	74.1	76.2	78.2	80.0	81.7	83.1	84.3	
	110	C	180.0	206.4	235.7	267.9	303.3	342.2	384.8	431.3	481.9	536.8	596.4			
		P	33.4	35.5	37.6	39.7	41.6	43.5	45.2	46.9	48.4	49.7	50.9			
		A	63.5	65.9	68.1	70.3	72.3	74.2	75.9	77.5	78.9	80.0	81.0			
	100	C	205.3	234.6	266.9	302.4	341.4	384.1	430.6	481.3	536.4	596.0	660.5			
		P	32.3	34.2	36.0	37.8	39.5	41.1	42.5	43.8	45.0	46.0	46.8			
		A	62.4	64.5	66.5	68.4	70.1	71.8	73.2	74.5	75.6	76.5	77.1			
90	C	230.2	262.2	297.6	336.3	378.8	425.2	475.6	530.5	589.9	654.1	723.4				
	P	30.9	32.6	34.2	35.7	37.1	38.3	39.5	40.5	41.3	42.0	42.4				
	A	60.9	62.7	64.5	66.1	67.6	69.0	70.2	71.2	72.0	72.5	72.9				

MODELO BLV

COMPRESOR BITZER

R-404A | 460V

Modelo	Compresor	H.P	TSC (°F)	TSE °F C=Capacidad kBtu's/h P=Potencia kW A= Amps.														
				-5	0	5	10	15	20	25	30	35	40	45				
JLD300BM6C	4PES-15Y	30	130	C	35.7	42.2	49.6	58.1	67.5	78.2	90.0	103.2	117.8	133.8	151.5			
				P	9.7	10.6	11.5	12.4	13.2	14.1	14.9	15.7	16.4	17.1	17.8			
				A	31.7	33.6	35.5	37.5	39.5	41.5	43.5	45.4	47.3	49.2	50.9			
			120	C	43.7	51.3	59.9	69.4	80.2	92.1	105.3	119.9	136.0	153.6	172.9			
				P	9.6	10.4	11.2	12.0	12.8	13.5	14.2	14.9	15.6	16.1	16.7			
				A	31.4	33.1	34.9	36.6	38.4	40.2	41.9	43.5	45.1	46.6	48.0			
		110	C	52.0	60.6	70.2	80.9	92.9	106.1	120.6	136.7	154.2	173.4	194.3				
			P	9.4	10.1	10.9	11.6	12.2	12.9	13.5	14.1	14.6	15.1	15.5				
			A	31.0	32.6	34.1	35.7	37.2	38.7	40.1	41.5	42.8	43.9	45.0				
			100	C	60.4	70.0	80.7	92.5	105.6	120.1	136.0	153.5	172.5	193.2	215.7			
				P	9.2	9.8	10.5	11.1	11.6	12.2	12.7	13.1	13.5	13.9	14.1			
				A	30.5	31.9	33.2	34.5	35.8	37.1	38.2	39.3	40.2	41.1	41.7			
		90	C	69.0	79.5	91.3	104.2	118.5	134.3	151.5	170.3	190.8	213.0	237.1				
			P	8.9	9.4	10.0	10.5	11.0	11.4	11.8	12.1	12.4	12.6	12.7				
			A	29.9	31.1	32.2	33.3	34.3	35.3	36.2	36.9	37.5	38.0	38.3				
			JLD400BM6C	4NES-20Y	40	130	C	44.8	52.6	61.4	71.3	82.4	94.8	108.7	124.1	141.1	159.9	180.4
							P	12.2	13.1	14.1	15.1	16.1	17.0	17.9	18.8	19.6	20.4	21.2
							A	37.5	39.6	41.8	44.1	46.3	48.6	50.9	53.1	55.3	57.3	59.3
120	C	54.3				63.2	73.2	84.5	97.0	111.0	126.4	143.5	162.2	182.7	205.2			
	P	11.9				12.8	13.6	14.5	15.4	16.2	17.0	17.8	18.5	19.1	19.7			
	A	36.8				38.7	40.7	42.7	44.7	46.7	48.6	50.5	52.3	54.0	55.6			
110	C	63.8			73.9	85.2	97.7	111.6	127.1	144.1	162.7	183.2	205.5	229.8				
	P	11.5			12.3	13.1	13.9	14.7	15.4	16.1	16.7	17.3	17.8	18.2				
	A	36.0			37.7	39.5	41.2	43.0	44.6	46.3	47.8	49.3	50.6	51.7				
	100	C			73.5	84.7	97.2	111.0	126.3	143.2	161.7	182.0	204.1	228.2	254.4			
		P			11.1	11.8	12.5	13.2	13.9	14.5	15.0	15.5	15.9	16.3	16.6			
		A			35.1	36.6	38.2	39.7	41.1	42.5	43.8	45.0	46.0	46.9	47.7			
90	C	83.3			95.6	109.3	124.4	141.1	159.4	179.4	201.3	225.1	250.9	278.9				
	P	10.6			11.3	11.9	12.5	13.0	13.5	13.9	14.2	14.5	14.7	14.8				
	A	34.2			35.5	36.8	38.0	39.2	40.3	41.2	42.0	42.7	43.2	43.5				
	JLD440BM6C	4JE-22Y			44	130	C	50.5	59.3	69.2	80.3	92.7	106.5	121.8	138.7	157.2	177.6	199.8
							P	13.4	14.5	15.6	16.7	17.7	18.8	19.8	20.8	21.7	22.6	23.5
							A	40.2	42.7	45.2	47.8	50.4	53.0	55.6	58.2	60.7	63.1	65.5
120			C	61.4		71.5	82.8	95.3	109.2	124.6	141.6	160.2	180.6	202.8	227.0			
			P	13.2		14.2	15.2	16.2	17.1	18.0	18.9	19.8	20.6	21.3	22.0			
			A	39.7		42.0	44.3	46.6	48.9	51.1	53.4	55.6	57.7	59.6	61.5			
110			C	72.3	83.7	96.3	110.2	125.6	142.5	161.1	181.4	203.6	227.7	253.8				
			P	12.9	13.8	14.7	15.6	16.4	17.2	17.9	18.6	19.2	19.8	20.3				
			A	39.1	41.1	43.1	45.1	47.0	49.0	50.8	52.6	54.3	55.8	57.2				
			100	C	83.3	95.9	109.7	125.0	141.8	160.3	180.4	202.4	226.3	252.2	280.3			
				P	12.6	13.3	14.1	14.8	15.5	16.1	16.7	17.3	17.8	18.2	18.6			
				A	38.2	39.9	41.6	43.3	45.0	46.5	48.0	49.4	50.6	51.7	52.6			
90			C	94.3	108.0	123.1	139.7	157.9	177.8	199.5	223.1	248.7	276.4	306.2				
			P	12.0	12.7	13.3	13.9	14.5	15.0	15.5	15.8	16.2	16.4	16.6				
			A	37.1	38.5	40.0	41.3	42.6	43.8	44.9	45.9	46.7	47.3	47.7				
			JLD500BM6C	4HE-25Y	50	130	C	61.4	71.6	83.0	95.8	110.1	126.0	143.6	163.0	184.3	207.7	233.3
							P	16.2	17.5	18.7	19.9	21.1	22.3	23.4	24.6	25.6	26.6	27.6
							A	50.0	52.8	55.7	58.5	61.4	64.3	67.2	70.0	72.7	75.4	77.9
120	C	74.1				85.8	98.8	113.3	129.4	147.1	166.7	188.1	211.6	237.3	265.2			
	P	15.9				17.1	18.2	19.3	20.4	21.4	22.4	23.4	24.3	25.1	25.9			
	A	49.4				51.9	54.4	57.0	59.6	62.1	64.6	67.0	69.3	71.5	73.6			
110	C	86.7			99.9	114.5	130.6	148.4	168.0	189.4	212.9	238.5	266.3	296.5				
	P	15.5			16.5	17.5	18.5	19.5	20.4	21.2	22.0	22.8	23.4	24.1				
	A	48.5			50.7	53.0	55.2	57.4	59.6	61.7	63.7	65.5	67.3	68.8				
	100	C			99.3	113.9	130.0	147.7	167.2	188.5	211.8	237.3	264.9	294.9	327.3			
		P			15.0	15.9	16.8	17.6	18.4	19.2	19.9	20.5	21.1	21.6	22.0			
		A			47.3	49.3	51.2	53.1	55.0	56.8	58.5	60.0	61.4	62.7	63.8			
90	C	111.8			127.7	145.3	164.5	185.6	208.7	233.8	261.1	290.8	322.8	357.4				
	P	14.4			15.1	15.9	16.6	17.2	17.8	18.4	18.9	19.3	19.6	19.8				
	A	45.9			47.6	49.2	50.8	52.3	53.7	55.0	56.1	57.0	57.8	58.4				
	JLD600BM6C	4GE-30Y			60	130	C	71.1	82.7	95.6	110.1	126.3	144.2	164.1	186.1	210.3	236.8	265.7
							P	18.8	20.2	21.6	23.0	24.4	25.7	27.0	28.3	29.5	30.7	31.8
							A	59.6	62.7	65.9	69.2	72.5	75.7	79.0	82.2	85.3	88.3	91.1
120			C	85.7		99.0	113.9	130.3	148.6	168.7	191.0	215.4	242.1	271.2	302.9			
			P	18.4		19.7	21.0	22.3	23.5	24.7	25.9	27.0	28.0	29.0	29.9			
			A	58.7		61.6	64.5	67.5	70.4	73.3	76.1	78.9	81.5	84.1	86.4			
110			C	100.3	115.3	131.9	150.3	170.6	192.9	217.3	244.1	273.3	305.0	339.4				
			P	18.0	19.1	20.3	21.4	22.5	23.5	24.5	25.5	26.3	27.2	27.9				
			A	57.6	60.2	62.8	65.4	68.0	70.5	72.9	75.2	77.4	79.4	81.3				
			100	C	114.7	131.3	149.7	169.9	192.1	216.5	243.2	272.2	303.8	338.0	375.1			
				P	17.3	18.4	19.4	20.4	21.3	22.2	23.0	23.8	24.5	25.1	25.6			
				A	56.3	58.5	60.8	63.1	65.2	67.3	69.3	71.2	72.9	74.4	75.7			
90			C	128.9	147.1	167.1	189.1	213.3	239.7	268.4	299.7	333.6	370.3	409.9				
			P	16.6	17.5	18.4	19.2	20.0	20.7	21.3	21.9	22.4	22.8	23.2				
			A	54.7	56.6	58.5	60.4	62.2	63.8	65.4	66.7	67.9	68.9	69.7				

Modelo	Compresor	H.P	TSC (°F)	TSE °F C=Capacidad kBTu's/h P=Potencia kW A= Amps.														
				-5	0	5	10	15	20	25	30	35	40	45				
JLD660BM6C	6JE-33Y	66	130	C	74.5	87.7	102.5	119.2	137.8	158.5	181.5	206.8	234.7	265.3	298.8			
				P	19.8	21.4	23.0	24.5	26.0	27.5	28.9	30.2	31.4	32.6	33.6			
				A	66.2	69.5	72.9	76.3	79.8	83.1	86.5	89.7	92.7	95.6	98.3			
			120	C	90.6	105.7	122.5	141.2	162.0	185.0	210.3	238.1	268.6	301.9	338.2			
				P	19.6	21.0	22.5	23.8	25.2	26.4	27.6	28.8	29.8	30.7	31.5			
				A	65.6	68.6	71.7	74.7	77.7	80.7	83.5	86.2	88.8	91.1	93.2			
			110	C	106.8	123.6	142.3	163.1	185.9	211.1	238.8	269.1	302.1	338.0	377.0			
				P	19.2	20.5	21.7	22.9	24.1	25.2	26.2	27.1	27.9	28.7	29.3			
				A	64.7	67.4	70.1	72.7	75.3	77.8	80.2	82.4	84.4	86.2	87.7			
			100	C	123.0	141.6	162.1	184.8	209.7	237.0	267.0	299.6	335.1	373.6	415.2			
				P	18.6	19.7	20.8	21.9	22.8	23.7	24.6	25.3	25.9	26.4	26.8			
				A	63.5	65.9	68.2	70.4	72.6	74.6	76.5	78.2	79.6	80.8	81.7			
			90	C	139.2	159.4	181.7	206.3	233.2	262.6	294.7	329.7	367.5	408.6	452.8			
				P	17.8	18.8	19.7	20.6	21.4	22.1	22.7	23.2	23.6	23.9	24.0			
				A	62.0	64.0	65.9	67.8	69.5	71.1	72.4	73.6	74.4	75.0	75.3			
			JLD700BM6C	6HE-35Y	70	130	C	90.4	105.5	122.3	141.2	162.2	185.6	211.5	240.0	271.4	305.7	343.3
							P	24.5	26.4	28.2	29.9	31.7	33.3	34.9	36.5	37.9	39.3	40.5
							A	76.5	80.6	84.8	89.1	93.2	97.3	101.4	105.2	108.9	112.4	115.6
120	C	109.0				126.2	145.4	166.7	190.3	216.3	245.0	276.5	311.0	348.6	389.6			
	P	24.0				25.7	27.3	28.9	30.4	31.9	33.3	34.6	35.8	37.0	38.0			
	A	75.3				79.0	82.8	86.6	90.3	93.9	97.3	100.6	103.7	106.6	109.2			
110	C	127.5				146.8	168.2	191.9	218.0	246.7	278.2	312.6	350.1	390.9	435.1			
	P	23.3				24.8	26.3	27.7	29.0	30.3	31.4	32.5	33.5	34.4	35.2			
	A	73.7				77.0	80.4	83.6	86.8	89.9	92.8	95.5	98.0	100.3	102.2			
100	C	146.0				167.3	190.9	216.8	245.4	276.7	310.8	348.1	388.6	432.5	480.0			
	P	22.4				23.8	25.0	26.2	27.4	28.4	29.4	30.3	31.0	31.7	32.2			
	A	71.7				74.6	77.5	80.3	83.0	85.6	87.9	90.0	91.9	93.5	94.8			
90	C	164.4				187.7	213.3	241.6	272.5	306.3	343.1	383.2	426.6	473.6	524.3			
	P	21.4				22.5	23.6	24.6	25.6	26.4	27.2	27.8	28.3	28.7	29.0			
	A	69.4				71.9	74.4	76.7	78.9	80.9	82.7	84.2	85.5	86.4	87.0			
JLD800BM6C	6GE-40Y	80				130	C	104.4	121.3	140.1	161.0	184.3	210.2	238.8	270.3	304.9	342.8	384.1
							P	28.6	30.7	32.7	34.7	36.7	38.6	40.4	42.2	43.8	45.4	46.9
							A	93.8	98.1	102.5	106.9	111.3	115.6	119.8	123.9	127.8	131.5	134.9
			120	C	125.7	145.0	166.4	190.2	216.5	245.6	277.5	312.5	350.9	392.6	438.0			
				P	28.0	29.9	31.7	33.5	35.3	36.9	38.5	40.1	41.5	42.8	44.0			
				A	92.4	96.4	100.3	104.3	108.2	112.0	115.6	119.1	122.4	125.5	128.3			
			110	C	146.6	168.4	192.4	219.0	248.3	280.4	315.7	354.2	396.2	441.8	491.2			
				P	27.2	28.9	30.5	32.1	33.6	35.1	36.5	37.7	38.9	40.0	41.0			
				A	90.6	94.2	97.7	101.2	104.6	107.8	111.0	113.9	116.6	119.1	121.3			
			100	C	167.5	191.6	218.2	247.5	279.7	314.9	353.4	395.4	441.0	490.4	543.8			
				P	26.1	27.6	29.1	30.5	31.8	33.0	34.2	35.2	36.2	37.0	37.7			
				A	88.5	91.6	94.7	97.7	100.6	103.4	105.9	108.3	110.4	112.3	113.8			
			90	C	188.3	214.7	243.9	275.9	310.9	349.2	390.9	436.2	485.4	538.5	595.8			
				P	25.0	26.3	27.5	28.7	29.8	30.8	31.7	32.6	33.3	33.8	34.3			
				A	86.1	88.8	91.4	94.0	96.4	98.6	100.6	102.4	104.0	105.2	106.1			
			JLD1000BM6C	6FE-50Y	100	130	C	128.6	149.1	171.8	197.1	225.2	256.3	290.6	328.4	369.8	415.2	464.6
							P	34.7	37.3	39.9	42.5	45.0	47.4	49.7	52.0	54.1	56.1	58.0
							A	129.8	135.3	140.7	145.9	151.0	155.7	160.2	164.4	168.2	171.6	174.6
120	C	154.5				177.9	204.0	232.8	264.6	299.6	338.1	380.3	426.3	476.5	531.1			
	P	34.2				36.6	38.9	41.2	43.5	45.6	47.7	49.6	51.4	53.1	54.6			
	A	128.8				133.9	138.8	143.6	148.1	152.4	156.4	160.1	163.4	166.3	168.7			
110	C	180.0				206.4	235.7	267.9	303.3	342.2	384.8	431.3	481.9	536.8	596.4			
	P	33.4				35.5	37.6	39.7	41.6	43.5	45.2	46.9	48.4	49.7	50.9			
	A	127.1				131.7	136.2	140.5	144.6	148.4	151.8	155.0	157.7	160.1	161.9			
100	C	205.3				234.6	266.9	302.4	341.4	384.1	430.6	481.3	536.4	596.0	660.5			
	P	32.3				34.2	36.0	37.8	39.5	41.1	42.5	43.8	45.0	46.0	46.8			
	A	124.8				128.9	132.9	136.7	140.3	143.5	146.5	149.1	151.2	153.0	154.3			
90	C	230.2				262.2	297.6	336.3	378.8	425.2	475.6	530.5	589.9	654.1	723.4			
	P	30.9				32.6	34.2	35.7	37.1	38.3	39.5	40.5	41.3	42.0	42.4			
	A	121.8				125.5	129.0	132.2	135.2	138.0	140.3	142.3	143.9	145.1	145.8			

MODELO BLV

COMPRESOR BITZER

R-404A | 230V

Modelo	Compresor	H.P	TSC (°F)	TSE °F C=Capacidad kBtu's/h P=Potencia kW A= Amps.												
				-45	-40	-35	-30	-25	-20	-15	-10	-5	0			
JLD300BL6D	4JE-15Y	30	130	C	9.8	13.2	17.0	21.3	26.1	31.7	37.9	45.1	53.1	62.3		
				P	5.9	6.8	7.8	8.8	9.8	10.9	11.9	13.0	14.1	15.2		
				A	13.0	13.7	14.5	15.3	16.3	17.4	18.5	19.7	20.9	22.2		
			120	C	13.3	17.4	22.0	27.1	32.9	39.3	46.6	54.9	64.1	74.4		
				P	6.2	7.1	8.0	8.9	9.9	10.9	11.9	12.9	13.9	14.9		
				A	13.3	13.9	14.6	15.5	16.4	17.3	18.4	19.5	20.6	21.7		
			110	C	17.1	21.9	27.2	33.1	39.8	47.2	55.5	64.8	75.1	86.6		
				P	6.4	7.2	8.1	9.0	9.9	10.8	11.7	12.6	13.5	14.4		
				A	13.5	14.1	14.7	15.5	16.3	17.2	18.2	19.1	20.1	21.2		
		100	C	21.1	26.6	32.7	39.4	46.9	55.2	64.5	74.8	86.2	98.8			
			P	6.6	7.3	8.1	8.9	9.8	10.6	11.4	12.2	13.0	13.8			
			A	13.6	14.1	14.8	15.5	16.2	17.0	17.9	18.7	19.6	20.5			
		JLD360BL6D	4HE-18Y	36	130	C	64.9	75.6	87.5	100.7	115.3	131.3	148.8	168.0	188.9	211.7
						P	4.6	4.7	4.7	4.6	4.5	4.3	4.0	3.6	3.2	2.7
						A	12.9	12.9	12.8	12.7	12.6	12.3	12.0	11.5	10.9	10.3
				120	C	13.1	17.1	21.5	26.5	32.1	38.5	45.7	54.0	63.3	73.7	
					P	7.4	8.5	9.6	10.7	11.9	13.1	14.4	15.7	17.0	18.3	
					A	14.1	15.0	16.0	17.2	18.4	19.8	21.2	22.7	24.3	25.9	
110	C			17.1	21.9	27.3	33.2	39.9	47.4	55.9	65.3	76.0	87.9			
	P			7.7	8.7	9.7	10.8	11.9	13.1	14.2	15.4	16.6	17.8			
	A			14.4	15.2	16.2	17.3	18.4	19.7	21.0	22.4	23.8	25.3			
100	C	21.4	27.1	33.3	40.2	47.9	56.5	66.1	76.8	88.8	102.0					
	P	7.8	8.8	9.7	10.8	11.8	12.9	13.9	15.0	16.1	17.2					
	A	14.5	15.3	16.2	17.2	18.3	19.5	20.7	21.9	23.2	24.5					
90	C	26.1	32.4	39.5	47.3	56.0	65.6	76.4	88.3	101.5	116.2					
	P	7.9	8.8	9.7	10.7	11.6	12.6	13.6	14.5	15.5	16.5					
	A	14.6	15.3	16.2	17.1	18.1	19.2	20.2	21.4	22.5	23.6					
JLD460BL6D	4GE-28Y	46	130	C	30.9	38.0	45.8	54.5	64.1	74.8	86.7	99.8	114.2	130.2		
				P	7.9	8.7	9.6	10.5	11.3	12.2	13.1	14.0	14.8	15.6		
				A	14.6	15.3	16.1	16.9	17.8	18.7	19.7	20.7	21.6	22.6		
			120	C	17.2	21.8	26.9	32.6	39.1	46.3	54.6	64.0	74.5	86.5		
				P	9.2	10.4	11.7	13.0	14.4	15.8	17.3	18.8	20.3	21.9		
				A	15.7	16.8	18.2	19.6	21.2	22.9	24.7	26.6	28.5	30.5		
			110	C	21.8	27.3	33.5	40.3	48.0	56.6	66.2	77.1	89.2	102.8		
				P	9.4	10.5	11.7	12.9	14.3	15.6	17.0	18.4	19.8	21.2		
				A	15.9	17.0	18.2	19.6	21.1	22.6	24.3	26.0	27.8	29.7		
		100	C	26.7	33.2	40.3	48.2	57.1	66.9	77.9	90.2	103.9	119.1			
			P	9.4	10.5	11.6	12.8	14.0	15.3	16.6	17.8	19.1	20.4			
			A	15.9	17.0	18.1	19.4	20.8	22.3	23.8	25.4	27.0	28.6			
		90	C	31.8	39.2	47.3	56.3	66.2	77.3	89.6	103.3	118.5	135.2			
			P	9.4	10.4	11.5	12.6	13.7	14.9	16.0	17.2	18.4	19.5			
			A	15.9	16.9	18.0	19.2	20.4	21.8	23.2	24.6	26.0	27.5			
		JLD560BL6D	4FE-28Y	56	130	C	37.2	45.4	54.4	64.4	75.4	87.7	101.2	116.3	132.8	151.1
						P	9.3	10.3	11.3	12.3	13.4	14.4	15.4	16.5	17.5	18.4
						A	15.8	16.8	17.8	18.8	20.0	21.2	22.4	23.6	24.9	26.1
120	C				18.3	24.4	31.1	38.4	46.4	55.4	65.5	76.7	89.3	103.3		
	P				10.2	11.8	13.5	15.2	16.9	18.7	20.5	22.4	24.2	26.0		
	A				21.3	22.7	24.3	26.0	27.8	29.7	31.8	33.9	36.1	38.3		
110	C				24.8	31.8	39.6	48.0	57.4	67.8	79.4	92.3	106.6	122.6		
	P				10.7	12.2	13.7	15.3	17.0	18.6	20.3	22.0	23.7	25.3		
	A				21.8	23.1	24.5	26.1	27.8	29.6	31.5	33.4	35.4	37.4		
100	C			31.4	39.4	48.1	57.7	68.3	80.1	93.2	107.7	123.8	141.7			
	P			11.0	12.4	13.8	15.3	16.8	18.4	19.9	21.4	23.0	24.4			
	A			22.0	23.3	24.6	26.1	27.6	29.3	31.0	32.8	34.5	36.3			
90	C			38.1	47.0	56.7	67.4	79.3	92.4	107.0	123.1	140.9	160.5			
	P			11.2	12.5	13.8	15.2	16.5	17.9	19.3	20.7	22.1	23.4			
	A			22.2	23.3	24.5	25.9	27.3	28.8	30.3	31.9	33.5	35.1			
90	C			44.9	54.6	65.3	77.0	90.1	104.5	120.5	138.2	157.7	179.2			
	P			11.2	12.4	13.6	14.9	16.1	17.4	18.6	19.8	21.0	22.2			
	A			22.2	23.2	24.3	25.5	26.8	28.1	29.5	30.9	32.3	33.6			

Modelo	Compresor	H.P	TSC (°F)	TSE °F C=Capacidad kBtu's/h P=Potencia kW A= Amps.													
				-45	-40	-35	-30	-25	-20	-15	-10	-5	0				
JLD680BL6D	6GE-34Y	68	130	C	26.0	33.3	41.3	50.1	59.9	70.9	83.2	97.1	112.7	130.2			
				P	14.3	16.2	18.1	20.2	22.3	24.5	26.7	28.9	31.2	33.4			
				A	24.9	26.9	29.0	31.4	33.8	36.4	39.1	41.9	44.7	47.6			
			120	C	34.0	42.5	51.8	62.0	73.5	86.2	100.5	116.4	134.2	154.0			
				P	14.6	16.4	18.2	20.1	22.0	24.0	26.1	28.1	30.2	32.2			
				A	25.3	27.1	29.1	31.3	33.5	35.9	38.4	40.9	43.5	46.1			
			110	C	41.9	51.5	62.1	73.8	86.9	101.4	117.5	135.4	155.4	177.5			
				P	14.7	16.3	18.0	19.8	21.6	23.4	25.3	27.1	29.0	30.8			
				A	25.4	27.1	28.9	30.9	33.0	35.1	37.4	39.7	42.0	44.3			
			100	C	49.7	60.5	72.4	85.6	100.2	116.4	134.3	154.3	176.3	200.7			
				P	14.6	16.2	17.7	19.3	21.0	22.6	24.3	26.0	27.6	29.2			
				A	25.4	26.9	28.6	30.4	32.3	34.2	36.2	38.2	40.3	42.3			
			90	C	57.7	69.6	82.8	97.4	113.5	131.4	151.2	173.1	197.2	223.9			
				P	14.4	15.8	17.3	18.7	20.2	21.7	23.2	24.7	26.1	27.5			
				A	25.2	26.6	28.1	29.7	31.4	33.1	34.9	36.7	38.4	40.2			
			JLD880BL6D	6FE-44Y	88	130	C	27.4	36.7	46.6	57.6	69.7	83.1	98.2	115.1	133.9	155.0
							P	16.3	18.6	21.1	23.6	26.1	28.8	31.4	34.1	36.7	39.3
							A	34.9	37.0	39.3	41.7	44.3	47.1	49.9	52.8	55.7	58.7
120	C	37.1				47.8	59.3	72.0	86.1	101.7	119.1	138.4	159.9	183.9			
	P	16.9				19.2	21.4	23.8	26.2	28.6	31.1	33.5	35.9	38.3			
	A	35.6				37.5	39.7	42.0	44.4	46.9	49.5	52.2	54.9	57.6			
110	C	47.1				59.1	72.2	86.6	102.5	120.2	139.8	161.6	185.8	212.5			
	P	17.4				19.5	21.6	23.8	26.0	28.2	30.5	32.7	34.9	37.1			
	A	36.0				37.8	39.8	41.9	44.1	46.5	48.8	51.2	53.7	56.1			
100	C	57.2				70.5	85.0	101.1	118.9	138.6	160.4	184.6	211.3	240.8			
	P	17.6				19.6	21.5	23.5	25.6	27.6	29.6	31.6	33.6	35.5			
	A	36.2				37.9	39.7	41.7	43.7	45.8	47.9	50.1	52.2	54.4			
90	C	67.4				81.9	97.9	115.6	135.1	156.8	180.8	207.3	236.5	268.7			
	P	17.7				19.5	21.3	23.1	24.9	26.8	28.6	30.3	32.1	33.7			
	A	36.3				37.8	39.5	41.2	43.0	44.9	46.8	48.7	50.6	52.4			

MODELO BLV

COMPRESOR BITZER

R-404A | 460V

49

Modelo	Compresor	H.P	TSC (°F)	TSE °F C=Capacidad kBtu's/h P=Potencia kW A= Amps.													
				-45	-40	-35	-30	-25	-20	-15	-10	-5	0				
JLD300BL6C	4JE-15Y	30	130	C	9.8	13.2	17.0	21.3	26.1	31.7	37.9	45.1	53.1	62.3			
				P	5.9	6.8	7.8	8.8	9.8	10.9	11.9	13.0	14.1	15.2			
				A	26.0	27.4	28.9	30.7	32.6	34.7	37.0	39.3	41.8	44.3			
			120	C	13.3	17.4	22.0	27.1	32.9	39.3	46.6	54.9	64.1	74.4			
				P	6.2	7.1	8.0	8.9	9.9	10.9	11.9	12.9	13.9	14.9			
				A	26.6	27.8	29.3	30.9	32.7	34.7	36.8	38.9	41.2	43.5			
		110	C	17.1	21.9	27.2	33.1	39.8	47.2	55.5	64.8	75.1	86.6				
			P	6.4	7.2	8.1	9.0	9.9	10.8	11.7	12.6	13.5	14.4				
			A	26.9	28.1	29.5	31.0	32.7	34.5	36.3	38.3	40.3	42.3				
			100	C	21.1	26.6	32.7	39.4	46.9	55.2	64.5	74.8	86.2	98.8			
				P	6.6	7.3	8.1	8.9	9.8	10.6	11.4	12.2	13.0	13.8			
				A	27.1	28.3	29.5	31.0	32.5	34.1	35.8	37.5	39.2	41.0			
		90	C	25.4	31.5	38.3	45.7	54.0	63.2	73.5	84.8	97.3	111.0				
			P	6.6	7.4	8.1	8.8	9.6	10.3	11.1	11.8	12.5	13.1				
			A	27.2	28.3	29.4	30.7	32.1	33.5	35.0	36.5	38.0	39.5				
			JLD360BL6C	4HE-18Y	36	130	C	13.1	17.1	21.5	26.5	32.1	38.5	45.7	54.0	63.3	73.7
							P	7.4	8.5	9.6	10.7	11.9	13.1	14.4	15.7	17.0	18.3
							A	28.3	30.1	32.1	34.4	36.9	39.6	42.5	45.5	48.6	51.9
120	C	17.1				21.9	27.3	33.2	39.9	47.4	55.9	65.3	76.0	87.9			
	P	7.7				8.7	9.7	10.8	11.9	13.1	14.2	15.4	16.6	17.8			
	A	28.8				30.4	32.4	34.5	36.9	39.4	42.0	44.8	47.7	50.6			
110	C	21.4			27.1	33.3	40.2	47.9	56.5	66.1	76.8	88.8	102.0				
	P	7.8			8.8	9.7	10.8	11.8	12.9	13.9	15.0	16.1	17.2				
	A	29.0			30.6	32.5	34.5	36.6	38.9	41.4	43.9	46.4	49.1				
	100	C			26.1	32.4	39.5	47.3	56.0	65.6	76.4	88.3	101.5	116.2			
		P			7.9	8.8	9.7	10.7	11.6	12.6	13.6	14.5	15.5	16.5			
		A			29.2	30.7	32.4	34.2	36.2	38.3	40.5	42.7	45.0	47.3			
90	C	30.9			38.0	45.8	54.5	64.1	74.8	86.7	99.8	114.2	130.2				
	P	7.9			8.7	9.6	10.5	11.3	12.2	13.1	14.0	14.8	15.6				
	A	29.2			30.6	32.1	33.8	35.6	37.5	39.4	41.3	43.3	45.2				
	JLD460BL6C	4GE-23Y			46	130	C	17.2	21.8	26.9	32.6	39.1	46.3	54.6	64.0	74.5	86.5
							P	9.2	10.4	11.7	13.0	14.4	15.8	17.3	18.8	20.3	21.9
							A	31.4	33.7	36.3	39.2	42.4	45.8	49.4	53.1	57.1	61.1
120			C	21.8		27.3	33.5	40.3	48.0	56.6	66.2	77.1	89.2	102.8			
			P	9.4		10.5	11.7	12.9	14.3	15.6	17.0	18.4	19.8	21.2			
			A	31.7		33.9	36.4	39.1	42.1	45.3	48.6	52.1	55.7	59.4			
110			C	26.7	33.2	40.3	48.2	57.1	66.9	77.9	90.2	103.9	119.1				
			P	9.4	10.5	11.6	12.8	14.0	15.3	16.6	17.8	19.1	20.4				
			A	31.9	33.9	36.3	38.9	41.6	44.5	47.6	50.8	54.0	57.3				
			100	C	31.8	39.2	47.3	56.3	66.2	77.3	89.6	103.3	118.5	135.2			
				P	9.4	10.4	11.5	12.6	13.7	14.9	16.0	17.2	18.4	19.5			
				A	31.8	33.8	36.0	38.4	40.9	43.6	46.3	49.2	52.0	54.9			
90			C	37.2	45.4	54.4	64.4	75.4	87.7	101.2	116.3	132.8	151.1				
			P	9.3	10.3	11.3	12.3	13.4	14.4	15.4	16.5	17.5	18.4				
			A	31.7	33.5	35.5	37.7	40.0	42.4	44.8	47.3	49.8	52.3				
			JLD560BL6C	4FE-28Y	56	130	C	18.3	24.4	31.1	38.4	46.4	55.4	65.5	76.7	89.3	103.3
							P	10.2	11.8	13.5	15.2	16.9	18.7	20.5	22.4	24.2	26.0
							A	42.6	45.4	48.5	51.9	55.6	59.5	63.6	67.8	72.1	76.6
120	C	24.8				31.8	39.6	48.0	57.4	67.8	79.4	92.3	106.6	122.6			
	P	10.7				12.2	13.7	15.3	17.0	18.6	20.3	22.0	23.7	25.3			
	A	43.5				46.1	49.0	52.2	55.6	59.2	63.0	66.9	70.8	74.8			
110	C	31.4			39.4	48.1	57.7	68.3	80.1	93.2	107.7	123.8	141.7				
	P	11.0			12.4	13.8	15.3	16.8	18.4	19.9	21.4	23.0	24.4				
	A	44.1			46.5	49.2	52.2	55.3	58.6	62.0	65.5	69.1	72.7				
	100	C			38.1	47.0	56.7	67.4	79.3	92.4	107.0	123.1	140.9	160.5			
		P			11.2	12.5	13.8	15.2	16.5	17.9	19.3	20.7	22.1	23.4			
		A			44.4	46.6	49.1	51.8	54.6	57.6	60.7	63.8	67.0	70.1			
90	C	44.9			54.6	65.3	77.0	90.1	104.5	120.5	138.2	157.7	179.2				
	P	11.2			12.4	13.6	14.9	16.1	17.4	18.6	19.8	21.0	22.2				
	A	44.4			46.4	48.7	51.1	53.6	56.3	59.0	61.8	64.5	67.2				

Modelo	Compresor	H.P	TSC (°F)	TSE °F C=Capacidad kBTu's/h P=Potencia kW A= Amps.												
				-45	-40	-35	-30	-25	-20	-15	-10	-5	0			
JLD680BL6C	6GE-36Y	68	130	C	26.0	33.3	41.3	50.1	59.9	70.9	83.2	97.1	112.7	130.2		
				P	14.3	16.2	18.1	20.2	22.3	24.5	26.7	28.9	31.2	33.4		
				A	49.8	53.8	58.1	62.7	67.7	72.9	78.3	83.8	89.5	95.2		
			120	C	34.0	42.5	51.8	62.0	73.5	86.2	100.5	116.4	134.2	154.0		
				P	14.6	16.4	18.2	20.1	22.0	24.0	26.1	28.1	30.2	32.2		
				A	50.6	54.2	58.2	62.5	67.1	71.8	76.7	81.8	86.9	92.1		
		110	C	41.9	51.5	62.1	73.8	86.9	101.4	117.5	135.4	155.4	177.5			
			P	14.7	16.3	18.0	19.8	21.6	23.4	25.3	27.1	29.0	30.8			
			A	50.9	54.2	57.9	61.8	66.0	70.3	74.7	79.3	83.9	88.5			
		100	C	49.7	60.5	72.4	85.6	100.2	116.4	134.3	154.3	176.3	200.7			
			P	14.6	16.2	17.7	19.3	21.0	22.6	24.3	26.0	27.6	29.2			
			A	50.7	53.8	57.2	60.7	64.5	68.4	72.4	76.5	80.5	84.6			
		90	C	57.7	69.6	82.8	97.4	113.5	131.4	151.2	173.1	197.2	223.9			
			P	14.4	15.8	17.3	18.7	20.2	21.7	23.2	24.7	26.1	27.5			
			A	50.3	53.1	56.1	59.4	62.7	66.2	69.8	73.3	76.9	80.4			
		JLD880BL6C	6FE-44Y	88	130	C	27.4	36.7	46.6	57.6	69.7	83.1	98.2	115.1	133.9	155.0
						P	16.3	18.6	21.1	23.6	26.1	28.8	31.4	34.1	36.7	39.3
						A	69.8	74.0	78.6	83.5	88.7	94.1	99.8	105.6	111.5	117.5
120	C				37.1	47.8	59.3	72.0	86.1	101.7	119.1	138.4	159.9	183.9		
	P				16.9	19.2	21.4	23.8	26.2	28.6	31.1	33.5	35.9	38.3		
	A				71.1	75.1	79.3	83.9	88.7	93.8	99.0	104.3	109.7	115.1		
110	C			47.1	59.1	72.2	86.6	102.5	120.2	139.8	161.6	185.8	212.5			
	P			17.4	19.5	21.6	23.8	26.0	28.2	30.5	32.7	34.9	37.1			
	A			72.0	75.7	79.6	83.9	88.3	92.9	97.7	102.5	107.3	112.2			
100	C			57.2	70.5	85.0	101.1	118.9	138.6	160.4	184.6	211.3	240.8			
	P			17.6	19.6	21.5	23.5	25.6	27.6	29.6	31.6	33.6	35.5			
	A			72.4	75.8	79.5	83.3	87.4	91.6	95.8	100.2	104.5	108.7			
90	C			67.4	81.9	97.9	115.6	135.1	156.8	180.8	207.3	236.5	268.7			
	P			17.7	19.5	21.3	23.1	24.9	26.8	28.6	30.3	32.1	33.7			
	A			72.5	75.6	78.9	82.4	86.0	89.8	93.6	97.4	101.1	104.8			

MODELO BLV

COMPRESOR BITZER

R-404A | 230V

Modelo	Compresor	H.P	TSC (°F)	TSE °F C=Capacidad kBtu's/h P=Potencia kW A= Amps.													
				-5	0	5	10	15	20	25	30	35	40			45	
JLD3000M6D	3DS3R17ME-TFD	30	130	C	45.658	55.528	65.921	76.898	88.519	100.847	113.941	127.863	142.674	158.436	175.208		
				P	11.403	12.012	12.655	13.319	13.992	14.658	15.306	15.922	16.493	17.004	17.443		
				A	19.6	20.0	20.6	21.2	21.8	22.6	23.3	24.0	24.8	25.5	26.2		
			120	C	53.057	63.081	73.810	85.307	97.631	110.845	125.010	140.185	156.433	173.814	192.390		
				P	10.761	11.336	11.935	12.544	13.151	13.742	14.304	14.823	15.286	15.680	15.991		
				A	18.5	19.0	19.5	20.1	20.7	21.4	22.1	22.7	23.3	23.9	24.4		
			110	C	60.306	70.532	81.648	93.715	106.793	120.944	136.228	152.707	170.441	189.492	209.921		
				P	10.174	10.708	11.255	11.802	12.337	12.845	13.313	13.728	14.077	14.346	14.522		
				A	17.6	18.1	18.6	19.1	19.7	20.3	20.9	21.4	21.9	22.3	22.6		
		100	C	67.194	77.674	89.227	101.914	115.795	130.933	147.387	165.220	184.491	205.262	227.595			
			P	9.618	10.104	10.593	11.071	11.526	11.944	12.312	12.617	12.844	12.982	13.015			
			A	16.8	17.3	17.8	18.3	18.8	19.3	19.7	20.1	20.4	20.7	20.8			
		90	C	73.513	84.297	96.337	109.694	124.429	140.604	158.279	177.515	198.373	220.915	245.201			
			P	9.072	9.503	9.926	10.329	10.697	11.019	11.279	11.466	11.565	11.564	11.448			
			A	16.1	16.6	17.0	17.4	17.8	18.2	18.5	18.8	18.9	18.9	18.9			
		JLD4000M6D	4DBNR20ME-TSK	40	130	C	61.147	71.883	83.538	96.252	110.165	125.417	142.148	160.499	180.609	202.619	226.668
						P	13.367	14.367	15.372	16.365	17.335	18.266	19.147	19.962	20.699	21.343	21.881
						A	22.5	23.5	24.5	25.6	26.7	27.8	28.8	29.8	30.8	31.7	32.5
120	C				69.838	81.344	93.872	107.562	122.554	138.988	157.003	176.741	198.341	221.944	247.689		
	P				12.973	13.869	14.759	15.632	16.473	17.268	18.003	18.666	19.242	19.718	20.080		
	A				21.8	22.7	23.7	24.6	25.6	26.5	27.4	28.3	29.1	29.8	30.4		
110	C				78.079	90.379	103.803	118.492	134.585	152.223	171.545	192.693	215.805	241.022	268.485		
	P				12.482	13.274	14.053	14.807	15.520	16.180	16.773	17.285	17.703	18.013	18.200		
	A				21.1	21.9	22.8	23.6	24.5	25.3	26.0	26.7	27.3	27.8	28.2		
100	C			85.871	98.986	113.329	129.039	146.256	165.120	185.772	208.351	232.999	259.854	289.057			
	P			11.905	12.595	13.265	13.900	14.489	15.016	15.467	15.831	16.092	16.237	16.252			
	A			20.4	21.1	21.9	22.6	23.3	23.9	24.5	25.0	25.4	25.7	25.9			
90	C			93.212	107.165	122.449	139.202	157.565	177.679	199.683	223.717	249.921	278.436	309.402			
	P			11.252	11.842	12.404	12.924	13.389	13.785	14.098	14.314	14.420	14.402	14.247			
	A			19.7	20.3	21.0	21.5	22.1	22.5	22.9	23.2	23.4	23.5	23.4			
JLD5000M6D	4DHNR22ME-TSK			50	130	C	66.722	78.531	91.367	105.382	120.727	137.553	156.009	176.249	198.421	222.677	249.169
						P	14.891	16.017	17.143	18.255	19.338	20.378	21.358	22.265	23.084	23.799	24.395
						A	25.3	26.4	27.6	28.8	30.0	31.2	32.4	33.6	34.6	35.6	36.6
		120	C		76.278	88.944	102.750	117.846	134.385	152.516	172.391	194.160	217.975	243.986	272.344		
			P		14.457	15.468	16.470	17.450	18.392	19.281	20.103	20.842	21.484	22.014	22.417		
			A		24.4	25.5	26.6	27.7	28.8	29.9	30.9	31.8	32.7	33.5	34.2		
		110	C		85.321	98.869	113.668	129.871	147.627	167.089	188.406	211.731	237.212	265.003	295.253		
			P		13.943	14.839	15.719	16.568	17.369	18.110	18.773	19.346	19.813	20.159	20.369		
			A		23.7	24.7	25.6	26.6	27.6	28.5	29.3	30.1	30.8	31.3	31.8		
		100	C	93.862	108.316	124.133	141.466	160.466	181.283	204.067	228.971	256.144	285.738	317.904			
			P	13.349	14.133	14.891	15.609	16.272	16.864	17.372	17.779	18.072	18.235	18.253			
			A	23.0	23.8	24.7	25.5	26.3	27.0	27.7	28.2	28.7	29.0	29.2			
		90	C	101.912	117.296	134.156	152.645	172.911	195.108	219.384	245.892	274.781	306.204	340.310			
			P	12.676	13.349	13.987	14.576	15.101	15.547	15.899	16.142	16.262	16.243	16.070			
			A	22.3	23.0	23.7	24.4	25.0	25.5	26.0	26.3	26.5	26.6	26.5			
		JLD6000M6D	4DJNR28ME-TSK	60	130	C	61.113	73.948	87.688	102.413	118.204	135.142	153.307	172.779	193.640	215.969	239.847
						P	13.865	15.164	16.440	17.686	18.889	20.042	21.133	22.153	23.093	23.941	24.689
						A	27.9	29.6	31.4	33.1	34.8	36.5	38.0	39.5	40.8	42.0	43.1
120	C				70.853	84.895	99.881	115.893	133.010	151.313	170.883	191.801	214.146	237.999	263.441		
	P				13.764	14.902	16.013	17.086	18.111	19.080	19.980	20.804	21.541	22.181	22.714		
	A				28.1	29.6	31.1	32.5	33.9	35.2	36.5	37.6	38.6	39.5	40.1		
110	C				80.205	95.301	111.382	128.528	146.819	166.335	187.158	209.368	233.046	258.271	285.125		
	P				13.453	14.439	15.391	16.299	17.154	17.945	18.662	19.297	19.838	20.277	20.602		
	A				28.0	29.2	30.4	31.6	32.7	33.7	34.6	35.5	36.2	36.7	37.1		
100	C			89.156	105.155	122.178	140.305	159.618	180.196	202.120	225.470	250.328	276.773	304.887			
	P			12.967	13.808	14.608	15.359	16.049	16.671	17.213	17.665	18.018	18.263	18.388			
	A			27.5	28.5	29.4	30.4	31.2	32.0	32.6	33.2	33.6	33.8	33.9			
90	C			97.694	114.444	132.257	151.214	171.396	192.883	215.756	240.095	265.981	293.493	322.714			
	P			12.339	13.041	13.698	14.298	14.832	15.291	15.665	15.943	16.115	16.173	16.105			
	A			26.8	27.6	28.3	29.0	29.6	30.1	30.5	30.8	30.9	30.9	30.7			

Modelo	Compresor	H.P	TSC (°F)	TSE °F C=Capacidad kBTu's/h P=Potencia kW A= Amps.													
				-5	0	5	10	15	20	25	30	35	40	45			
JLD7000M6D	6D.HNR35ME-TSK	70	130	C	99,267	117,779	138,050	160,004	183,567	208,663	235,216	263,152	292,393	322,865	354,493		
				P	22,071	23,605	25,194	26,815	28,445	30,058	31,631	33,141	34,562	35,872	37,047		
				A	37.0	38.3	39.8	41.6	43.5	45.4	47.5	49.5	51.5	53.3	55.1		
			120	C	112,394	131,408	152,458	175,471	200,370	227,080	255,526	285,631	317,321	350,520	385,153		
				P	21,240	22,599	24,007	25,439	26,871	28,279	29,639	30,928	32,121	33,194	34,124		
				A	35.4	36.6	38.1	39.7	41.4	43.2	45.0	46.8	48.5	50.1	51.4		
			110	C	124,651	144,274	166,211	190,389	216,731	245,162	275,607	307,990	342,236	378,268	416,013		
				P	20,246	21,444	22,682	23,936	25,183	26,399	27,558	28,639	29,616	30,465	31,164		
				A	33.8	35.0	36.3	37.8	39.3	40.9	42.5	44.0	45.4	46.7	47.7		
			100	C	136,256	156,594	179,525	204,975	232,867	263,127	295,678	330,445	367,353	406,326	447,289		
				P	19,127	20,176	21,258	22,347	23,422	24,457	25,429	26,313	27,086	27,725	28,204		
				A	32.3	33.3	34.5	35.8	37.2	38.6	39.9	41.2	42.3	43.2	43.9		
		90	C	147,424	168,585	192,618	219,446	248,995	281,190	315,954	353,212	392,890	434,910	479,199			
			P	17,923	18,835	19,772	20,710	21,625	22,492	23,288	23,989	24,571	25,011	25,283			
			A	30.8	31.7	32.8	33.9	35.1	36.2	37.3	38.3	39.1	39.7	40.0			
		JLD8000M6D	6D.NR40ME-TSN	80	130	C	118,773	140,129	163,793	189,642	217,558	247,419	279,106	312,498	347,475	383,916	421,702
						P	26,909	28,702	30,582	32,518	34,476	36,425	38,333	40,166	41,893	43,482	44,898
						A	45.1	46.6	48.3	50.4	52.6	55.0	57.5	60.0	62.4	64.7	66.8
					120	C	133,569	155,703	180,458	207,713	237,348	269,243	303,277	339,331	377,283	417,014	458,403
						P	25,819	27,412	29,083	30,797	32,524	34,231	35,885	37,455	38,906	40,208	41,329
						A	43.1	44.4	46.1	48.0	50.1	52.3	54.5	56.7	58.8	60.7	62.4
					110	C	147,544	170,558	196,506	225,269	256,726	290,757	327,241	366,059	407,089	450,212	495,307
						P	24,507	25,915	27,389	28,897	30,406	31,883	33,297	34,616	35,806	36,835	37,672
						A	40.9	42.2	43.8	45.6	47.4	49.4	51.3	53.2	54.9	56.5	57.8
100	C				160,937	184,933	212,178	242,551	275,932	312,202	351,238	392,922	437,133	483,750	532,653		
	P				23,038	24,273	25,564	26,878	28,182	29,444	30,631	31,712	32,654	33,424	33,991		
	A				38.8	40.0	41.5	43.0	44.7	46.4	48.1	49.6	51.0	52.1	53.0		
90	C			173,987	199,067	227,711	259,797	295,205	333,815	375,507	420,159	467,653	517,867	570,681			
	P			21,471	22,548	23,669	24,802	25,915	26,975	27,949	28,806	29,513	30,037	30,347			
	A			36.8	37.9	39.2	40.6	42.0	43.5	44.8	46.0	47.0	47.8	48.1			

MODELO BLV

COMPRESOR COPELAND

R-449A | 460V

Modelo	Compresor	H.P	TSC (°F)	TSE °F C=Capacidad kBtu's/h P=Potencia kW A= Amps.													
				-5	0	5	10	15	20	25	30	35	40			45	
JLD3000M6C	3DS3R17ME-TFD	30	130	C	45.658	55.528	65.921	76.898	88.519	100.847	113.941	127.863	142.674	158.436	175.208		
				P	11.403	12.012	12.655	13.319	13.992	14.658	15.306	15.922	16.493	17.004	17.443		
				A	39.1	40.0	41.1	42.3	43.7	45.1	46.6	48.1	49.6	51.0	52.4		
			120	C	53.057	63.081	73.810	85.307	97.631	110.845	125.010	140.185	156.433	173.814	192.390		
				P	10.761	11.336	11.935	12.544	13.151	13.742	14.304	14.823	15.286	15.680	15.991		
				A	37.0	37.9	39.0	40.2	41.5	42.8	44.1	45.4	46.7	47.8	48.9		
			110	C	60.306	70.532	81.648	93.715	106.793	120.944	136.228	152.707	170.441	189.492	209.921		
				P	10.174	10.708	11.255	11.802	12.337	12.845	13.313	13.728	14.077	14.346	14.522		
				A	35.2	36.1	37.2	38.3	39.4	40.6	41.7	42.8	43.8	44.6	45.3		
		100	C	67.194	77.674	89.227	101.914	115.795	130.933	147.387	165.220	184.491	205.262	227.595			
			P	9.618	10.104	10.593	11.071	11.526	11.944	12.312	12.617	12.844	12.982	13.015			
			A	33.6	34.5	35.5	36.5	37.5	38.5	39.4	40.2	40.8	41.3	41.6			
		90	C	73.513	84.297	96.337	109.694	124.429	140.604	158.279	177.515	198.373	220.915	245.201			
			P	9.072	9.503	9.926	10.329	10.697	11.019	11.279	11.466	11.565	11.564	11.448			
			A	32.2	33.1	34.0	34.9	35.7	36.4	37.0	37.5	37.8	37.9	37.7			
		JLD4000M6C	4DBNR20ME-TSK	40	130	C	61.147	71.883	83.538	96.252	110.165	125.417	142.148	160.499	180.609	202.619	226.668
						P	13.367	14.367	15.372	16.365	17.335	18.266	19.147	19.962	20.699	21.343	21.881
						A	45.0	47.0	49.1	51.2	53.4	55.5	57.6	59.6	61.6	63.4	65.0
120	C				69.838	81.344	93.872	107.562	122.554	138.988	157.003	176.741	198.341	221.944	247.689		
	P				12.973	13.869	14.759	15.632	16.473	17.268	18.003	18.666	19.242	19.718	20.080		
	A				43.5	45.4	47.3	49.3	51.2	53.1	54.9	56.6	58.2	59.6	60.9		
110	C				78.079	90.379	103.803	118.492	134.585	152.223	171.545	192.693	215.805	241.022	268.485		
	P				12.482	13.274	14.053	14.807	15.520	16.180	16.773	17.285	17.703	18.013	18.200		
	A				42.1	43.8	45.6	47.3	49.0	50.6	52.1	53.4	54.6	55.7	56.5		
100	C			85.871	98.986	113.329	129.039	146.256	165.120	185.772	208.351	232.999	259.854	289.057			
	P			11.905	12.595	13.265	13.900	14.489	15.016	15.467	15.831	16.092	16.237	16.252			
	A			40.7	42.3	43.8	45.2	46.6	47.9	49.0	50.0	50.8	51.4	51.8			
90	C			93.212	107.165	122.449	139.202	157.565	177.679	199.683	223.717	249.921	278.436	309.402			
	P			11.252	11.842	12.404	12.924	13.389	13.785	14.098	14.314	14.420	14.402	14.247			
	A			39.3	40.7	41.9	43.1	44.1	45.1	45.8	46.4	46.8	46.9	46.8			
JLD5000M6C	4DHNR22ME-TSK			50	130	C	66.722	78.531	91.367	105.382	120.727	137.553	156.009	176.249	198.421	222.677	249.169
						P	14.891	16.017	17.143	18.255	19.338	20.378	21.358	22.265	23.084	23.799	24.395
						A	50.6	52.8	55.2	57.6	60.1	62.5	64.8	67.1	69.3	71.3	73.1
		120	C		76.278	88.944	102.750	117.846	134.385	152.516	172.391	194.160	217.975	243.986	272.344		
			P		14.457	15.468	16.470	17.450	18.392	19.281	20.103	20.842	21.484	22.014	22.417		
			A		48.9	51.0	53.2	55.4	57.6	59.7	61.7	63.7	65.5	67.1	68.5		
		110	C		85.321	98.869	113.668	129.871	147.627	167.089	188.406	211.731	237.212	265.003	295.253		
			P		13.943	14.839	15.719	16.568	17.369	18.110	18.773	19.346	19.813	20.159	20.369		
			A		47.4	49.3	51.3	53.2	55.1	56.9	58.6	60.2	61.5	62.7	63.6		
		100	C	93.862	108.316	124.133	141.466	160.466	181.283	204.067	228.971	256.144	285.738	317.904			
			P	13.349	14.133	14.891	15.609	16.272	16.864	17.372	17.779	18.072	18.235	18.253			
			A	45.9	47.7	49.4	51.0	52.6	54.1	55.4	56.5	57.4	58.1	58.5			
		90	C	101.912	117.296	134.156	152.645	172.911	195.108	219.384	245.892	274.781	306.204	340.310			
			P	12.676	13.349	13.987	14.576	15.101	15.547	15.899	16.142	16.262	16.243	16.070			
			A	44.5	46.0	47.4	48.8	50.0	51.0	51.9	52.6	53.0	53.2	53.0			
		JLD6000M6C	4DJNR28ME-TSK	60	130	C	61.113	73.948	87.688	102.413	118.204	135.142	153.307	172.779	193.640	215.969	239.847
						P	13.865	15.164	16.440	17.686	18.889	20.042	21.133	22.153	23.093	23.941	24.689
						A	55.7	59.3	62.8	66.3	69.7	72.9	76.1	79.0	81.6	84.0	86.1
120	C				70.853	84.895	99.881	115.893	133.010	151.313	170.883	191.801	214.146	237.999	263.441		
	P				13.764	14.902	16.013	17.086	18.111	19.080	19.980	20.804	21.541	22.181	22.714		
	A				56.2	59.2	62.1	65.0	67.8	70.5	72.9	75.2	77.2	78.9	80.3		
110	C				80.205	95.301	111.382	128.528	146.819	166.335	187.158	209.368	233.046	258.271	285.125		
	P				13.453	14.439	15.391	16.299	17.154	17.945	18.662	19.297	19.838	20.277	20.602		
	A				55.9	58.4	60.8	63.1	65.3	67.4	69.3	70.9	72.3	73.4	74.1		
100	C			89.156	105.155	122.178	140.305	159.618	180.196	202.120	225.470	250.328	276.773	304.887			
	P			12.967	13.808	14.608	15.359	16.049	16.671	17.213	17.665	18.018	18.263	18.388			
	A			55.0	57.0	58.9	60.7	62.4	63.9	65.3	66.3	67.1	67.6	67.7			
90	C			97.694	114.444	132.257	151.214	171.396	192.883	215.756	240.095	265.981	293.493	322.714			
	P			12.339	13.041	13.698	14.298	14.832	15.291	15.665	15.943	16.115	16.173	16.105			
	A			53.7	55.2	56.6	58.0	59.2	60.2	61.0	61.6	61.8	61.8	61.3			

Modelo	Compresor	H.P	TSC (°F)	TSE °F C=Capacidad kBTu's/h P=Potencia kW A= Amps.													
				-5	0	5	10	15	20	25	30	35	40	45			
JLD7000M6C	60HNR35ME-TSK	70	130	C	99,267	117,779	138,050	160,004	183,567	208,663	235,216	263,152	292,393	322,865	354,493		
				P	22,071	23,605	25,194	26,815	28,445	30,058	31,631	33,141	34,562	35,872	37,047		
				A	74.0	76.6	79.7	83.1	86.9	90.9	94.9	99.0	102.9	106.7	110.1		
			120	C	112,394	131,408	152,458	175,471	200,370	227,080	255,526	285,631	317,321	350,520	385,153		
				P	21,240	22,599	24,007	25,439	26,871	28,279	29,639	30,928	32,121	33,194	34,124		
				A	70.9	73.3	76.2	79.4	82.8	86.4	90.0	93.6	97.0	100.1	102.9		
			110	C	124,651	144,274	166,211	190,389	216,731	245,162	275,607	307,990	342,236	378,268	416,013		
				P	20,246	21,444	22,682	23,936	25,183	26,399	27,558	28,639	29,616	30,465	31,164		
				A	67.7	70.0	72.6	75.5	78.6	81.8	85.0	88.0	90.8	93.3	95.4		
		100	C	136,256	156,594	179,525	204,975	232,867	263,127	295,678	330,445	367,353	406,326	447,289			
			P	19,127	20,176	21,258	22,347	23,422	24,457	25,429	26,313	27,086	27,725	28,204			
			A	64.5	66.6	69.0	71.6	74.4	77.1	79.8	82.3	84.5	86.4	87.8			
		90	C	147,424	168,585	192,618	219,446	248,995	281,190	315,954	353,212	392,890	434,910	479,199			
			P	17,923	18,835	19,772	20,710	21,625	22,492	23,288	23,989	24,571	25,011	25,283			
			A	61.5	63.4	65.5	67.8	70.2	72.5	74.7	76.6	78.2	79.4	80.1			
		JLD8000M6C	60JNR40ME-TSN	80	130	C	118,773	140,129	163,793	189,642	217,558	247,419	279,106	312,498	347,475	383,916	421,702
						P	26,909	28,702	30,582	32,518	34,476	36,425	38,333	40,166	41,893	43,482	44,898
						A	90.2	93.1	96.7	100.8	105.3	110.1	115.0	119.9	124.8	129.4	133.6
120	C				133,569	155,703	180,458	207,713	237,348	269,243	303,277	339,331	377,283	417,014	458,403		
	P				25,819	27,412	29,083	30,797	32,524	34,231	35,885	37,455	38,906	40,208	41,329		
	A				86.1	88.9	92.2	96.1	100.2	104.6	109.0	113.3	117.5	121.4	124.8		
110	C				147,544	170,558	196,506	225,269	256,726	290,757	327,241	366,059	407,089	450,212	495,307		
	P				24,507	25,915	27,389	28,897	30,406	31,883	33,297	34,616	35,806	36,835	37,672		
	A				81.9	84.5	87.6	91.1	94.9	98.8	102.6	106.4	109.9	113.0	115.5		
100	C			160,937	184,933	212,178	242,551	275,932	312,202	351,238	392,922	437,133	483,750	532,653			
	P			23,038	24,273	25,564	26,878	28,182	29,444	30,631	31,712	32,654	33,424	33,991			
	A			77.7	80.1	82.9	86.1	89.4	92.8	96.1	99.2	102.0	104.3	106.0			
90	C			173,987	199,067	227,711	259,797	295,205	333,815	375,507	420,159	467,653	517,867	570,681			
	P			21,471	22,548	23,669	24,802	25,915	26,975	27,949	28,806	29,513	30,037	30,347			
	A			73.6	75.8	78.4	81.2	84.1	86.9	89.6	92.0	94.0	95.5	96.3			

MODELO BLV

COMPRESOR COPELAND

R-449A | 230V

Modelo	Compresor	H.P	TSC (°F)	TSE °F C=Capacidad kBtu's/h P=Potencia kW A= Amps.												
				-45	-40	-35	-30	-25	-20	-15	-10	-5	0			
JLD2400L6D	40BNF54KE-TSK	24	130	C	3.544	8.436	13.810	19.675	26.041	32.916	40.309	48.229	56.683	65.682		
				P	4.868	5.781	6.744	7.746	8.775	9.821	10.871	11.916	12.944	13.943		
				A	10.7	11.9	13.1	14.3	15.5	16.7	17.9	19.1	20.3	21.5		
			120	C	9.654	14.448	19.815	25.765	32.307	39.448	47.198	55.565	64.558	74.186		
				P	5.353	6.176	7.046	7.951	8.879	9.821	10.763	11.696	12.608	13.488		
				A	11.4	12.5	13.5	14.6	15.6	16.7	17.8	18.9	19.9	21.0		
			110	C	14.962	19.688	25.079	31.143	37.889	45.326	53.463	62.308	71.870	82.158		
				P	5.649	6.389	7.171	7.985	8.818	9.660	10.500	11.326	12.128	12.894		
				A	11.7	12.7	13.6	14.5	15.4	16.4	17.3	18.3	19.3	20.2		
		100	C	19.506	24.195	29.638	35.847	42.828	50.591	59.144	68.497	78.657	89.634			
			P	5.783	6.445	7.145	7.872	8.615	9.364	10.107	10.832	11.529	12.187			
			A	11.8	12.6	13.3	14.2	15.0	15.8	16.6	17.5	18.3	19.2			
		90	C	23.325	28.005	33.532	39.914	47.160	55.279	64.279	74.169	84.958	96.654			
			P	5.778	6.367	6.990	7.637	8.296	8.957	9.608	10.238	10.836	11.390			
			A	11.6	12.3	13.0	13.7	14.4	15.1	15.8	16.5	17.3	18.0			
		JLD3000L6D	40HNF63KE-TSK	30	130	C	3.233	11.559	19.444	27.053	34.551	42.103	49.874	58.028	66.731	76.148
						P	4.023	6.240	8.146	9.788	11.209	12.454	13.568	14.596	15.582	16.571
						A	11.4	13.9	16.2	18.1	19.7	21.2	22.5	23.7	24.8	25.9
120	C				9.980	17.921	25.573	33.099	40.664	48.433	56.572	65.245	74.616	84.852		
	P				4.727	6.719	8.415	9.859	11.094	12.167	13.122	14.003	14.856	15.724		
	A				12.3	14.6	16.5	18.2	19.6	20.9	22.0	23.0	24.1	25.1		
110	C				16.312	23.920	31.388	38.881	46.563	54.600	63.156	72.397	82.487	93.592		
	P				5.230	7.015	8.517	9.779	10.847	11.764	12.576	13.327	14.062	14.827		
	A				12.8	14.8	16.5	17.9	19.2	20.2	21.2	22.1	23.0	24.0		
100	C			22.071	29.395	36.730	44.239	52.088	60.443	69.467	79.326	90.185	102.208			
	P			5.567	7.162	8.486	9.584	10.500	11.278	11.964	12.602	13.237	13.914			
	A			13.0	14.8	16.2	17.5	18.5	19.4	20.2	21.0	21.8	22.7			
90	C			27.097	34.187	41.437	49.013	57.080	65.802	75.344	85.871	97.548	110.540			
	P			5.773	7.195	8.358	9.308	10.088	10.744	11.321	11.862	12.414	13.020			
	A			13.1	14.6	15.8	16.8	17.7	18.4	19.1	19.8	20.5	21.3			
JLD4400L6D	40INF76KE-TSK			44	130	C	3.090	13.117	22.520	31.625	40.754	50.230	60.377	71.519	83.979	98.081
						P	6.436	8.367	10.136	11.770	13.298	14.746	16.144	17.519	18.899	20.312
						A	14.9	17.3	19.4	21.4	23.3	25.0	26.7	28.4	30.1	32.0
		120	C		11.641	21.463	30.778	39.910	49.183	58.920	69.444	81.079	94.149	108.976		
			P		7.085	8.837	10.430	11.889	13.245	14.524	15.755	16.965	18.183	19.437		
			A		15.8	17.9	19.9	21.6	23.2	24.7	26.2	27.7	29.2	30.9		
		110	C		19.360	29.053	38.355	47.591	57.083	67.156	78.133	90.337	104.091	119.720		
			P		7.542	9.127	10.555	11.852	13.047	14.169	15.245	16.303	17.371	18.477		
			A		16.3	18.2	19.9	21.4	22.8	24.1	25.3	26.6	28.0	29.5		
		100	C	26.215	35.854	45.219	54.634	64.422	74.906	86.411	99.259	113.775	130.281			
			P	7.819	9.249	10.523	11.670	12.717	13.693	14.626	15.543	16.472	17.443			
			A	16.5	18.2	19.6	20.9	22.1	23.2	24.3	25.4	26.6	27.9			
		90	C	32.173	41.834	51.337	61.007	71.166	82.138	94.246	107.815	123.167	140.626			
			P	7.927	9.213	10.346	11.354	12.265	13.108	13.909	14.697	15.500	16.347			
			A	16.5	18.0	19.2	20.3	21.3	22.2	23.1	24.1	25.1	26.3			
		JLD5400L6D	60HNF93KE-TSK	54	130	C	3.283	14.429	25.345	36.296	47.550	59.374	72.035	85.800	100.937	117.712
						P	15.590	15.103	15.168	15.710	16.655	17.928	19.454	21.159	22.967	24.803
						A	27.5	27.2	27.4	28.2	29.3	30.8	32.7	34.7	37.0	39.5
120	C				15.053	25.835	36.539	47.432	58.782	70.856	83.921	98.243	114.091	131.731		
	P				14.831	14.494	14.668	15.277	16.248	17.504	18.972	20.576	22.242	23.895		
	A				26.7	26.6	26.9	27.7	28.8	30.3	32.0	34.0	36.1	38.3		
110	C				24.761	35.268	45.852	56.779	68.316	80.731	94.290	109.262	125.911	144.507		
	P				14.013	13.814	14.083	14.746	15.728	16.955	18.351	19.843	21.354	22.811		
	A				25.7	25.7	26.1	26.9	28.0	29.4	31.0	32.8	34.7	36.7		
100	C			32.683	43.007	53.562	64.613	76.429	89.276	103.421	119.132	136.675	156.318			
	P			13.152	13.076	13.428	14.132	15.114	16.298	17.610	18.975	20.318	21.565			
	A			24.6	24.6	25.1	25.9	27.0	28.3	29.8	31.4	33.1	34.9			
90	C			39.094	49.327	59.944	71.211	83.396	96.766	111.589	128.130	146.658	167.439			
	P			12.263	12.299	12.721	13.452	14.420	15.548	16.763	17.989	19.151	20.176			
	A			23.4	23.5	24.0	24.8	25.9	27.1	28.5	29.9	31.4	32.8			

Modelo	Compresor	H.P	TSC (°F)	TSE °F C=Capacidad kBtu's/h P=Potencia kW A= Amps.										
				-45	-40	-35	-30	-25	-20	-15	-10	-5	0	
JLD6000L6D	6DJNF1ME-TSK	60	130	C	1,469	15,926	29,845	43,584	57,503	71,960	87,313	103,923	122,147	142,344
				P	16,098	16,437	17,191	18,306	19,727	21,399	23,266	25,274	27,367	29,490
				A	27.6	29.0	30.5	32.2	34.1	36.1	38.3	40.7	43.3	46.1
			120	C	16,208	30,097	43,649	57,221	71,173	85,863	101,650	118,894	137,952	159,183
				P	15,645	16,048	16,831	17,940	19,319	20,914	22,669	24,529	26,439	28,343
				A	27.5	28.8	30.3	31.8	33.6	35.5	37.5	39.7	42.0	44.6
			110	C	28,400	41,841	55,145	68,670	82,776	97,819	114,160	132,158	152,170	174,556
				P	15,071	15,529	16,333	17,428	18,757	20,266	21,901	23,604	25,322	27,000
				A	27.0	28.2	29.6	31.1	32.7	34.4	36.3	38.2	40.4	42.6
			100	C	38,376	51,490	64,667	78,265	92,644	108,161	125,176	144,047	165,133	188,793
				P	14,395	14,902	15,718	16,789	18,061	19,476	20,981	22,520	24,039	25,481
				A	26.2	27.4	28.7	30.1	31.6	33.1	34.8	36.5	38.4	40.4
			90	C	46,470	59,376	72,546	86,337	101,109	117,219	135,028	154,893	177,174	202,228
				P	13,639	14,185	15,005	16,046	17,250	18,564	19,931	21,298	22,608	23,806
				A	25.4	26.5	27.7	29.0	30.3	31.7	33.1	34.7	36.3	38.0

MODELO BLV

COMPRESOR COPELAND

R-449A | 460V

Modelo	Compresor	H.P	TSC (°F)	TSE °F C=Capacidad kBtu's/h P=Potencia kW A= Amps.										
				-45	-40	-35	-30	-25	-20	-15	-10	-5	0	
JLD2400L6C	40BNF54KE-TSK	24	130	C	3.544	8.436	13.810	19.675	26.041	32.916	40.309	48.229	56.683	65.682
				P	4.868	5.781	6.744	7.746	8.775	9.821	10.871	11.916	12.944	13.943
				A	21.5	23.8	26.2	28.6	31.0	33.4	35.8	38.2	40.6	43.0
			120	C	9.654	14.448	19.815	25.765	32.307	39.448	47.198	55.565	64.558	74.186
				P	5.353	6.176	7.046	7.951	8.879	9.821	10.763	11.696	12.608	13.488
				A	22.9	25.0	27.1	29.2	31.3	33.4	35.6	37.7	39.9	42.1
		110	C	14.962	19.688	25.079	31.143	37.889	45.326	53.463	62.308	71.870	82.158	
			P	5.649	6.389	7.171	7.985	8.818	9.660	10.500	11.326	12.128	12.894	
			A	23.5	25.3	27.1	29.0	30.9	32.8	34.7	36.6	38.5	40.4	
		100	C	19.506	24.195	29.638	35.847	42.828	50.591	59.144	68.497	78.657	89.634	
			P	5.783	6.445	7.145	7.872	8.615	9.364	10.107	10.832	11.529	12.187	
			A	23.5	25.1	26.7	28.3	29.9	31.6	33.3	34.9	36.6	38.3	
90	C	23.325	28.005	33.532	39.914	47.160	55.279	64.279	74.169	84.958	96.654			
	P	5.778	6.367	6.990	7.637	8.296	8.957	9.608	10.238	10.836	11.390			
	A	23.3	24.6	25.9	27.3	28.7	30.1	31.6	33.0	34.5	36.0			
JLD3000L6C	40HNF63KE-TSK	30	130	C	3.233	11.559	19.444	27.053	34.551	42.103	49.874	58.028	66.731	76.148
				P	4.023	6.240	8.146	9.788	11.209	12.454	13.568	14.596	15.582	16.571
				A	22.8	27.9	32.3	36.2	39.5	42.4	45.0	47.3	49.6	51.9
			120	C	9.980	17.921	25.573	33.099	40.664	48.433	56.572	65.245	74.616	84.852
				P	4.727	6.719	8.415	9.859	11.094	12.167	13.122	14.003	14.856	15.724
				A	24.6	29.1	33.0	36.4	39.2	41.7	44.0	46.1	48.1	50.2
		110	C	16.312	23.920	31.388	38.881	46.563	54.600	63.156	72.397	82.487	93.592	
			P	5.230	7.015	8.517	9.779	10.847	11.764	12.576	13.327	14.062	14.827	
			A	25.6	29.6	33.0	35.9	38.3	40.5	42.4	44.2	46.0	47.9	
		100	C	22.071	29.395	36.730	44.239	52.088	60.443	69.467	79.326	90.185	102.208	
			P	5.567	7.162	8.486	9.584	10.500	11.278	11.964	12.602	13.237	13.914	
			A	26.1	29.6	32.5	34.9	37.0	38.8	40.4	42.0	43.6	45.3	
90	C	27.097	34.187	41.437	49.013	57.080	65.802	75.344	85.871	97.548	110.540			
	P	5.773	7.195	8.358	9.308	10.088	10.744	11.321	11.862	12.414	13.020			
	A	26.2	29.2	31.7	33.7	35.4	36.9	38.2	39.6	41.0	42.6			
JLD4400L6C	40INF76KE-TSK	44	130	C	3.090	13.117	22.520	31.625	40.754	50.230	60.377	71.519	83.979	98.081
				P	6.436	8.367	10.136	11.770	13.298	14.746	16.144	17.519	18.899	20.312
				A	29.7	34.5	38.9	42.8	46.5	50.0	53.4	56.8	60.3	64.0
			120	C	11.641	21.463	30.778	39.910	49.183	58.920	69.444	81.079	94.149	108.976
				P	7.085	8.837	10.430	11.889	13.245	14.524	15.755	16.965	18.183	19.437
				A	31.6	35.9	39.7	43.2	46.4	49.4	52.4	55.3	58.4	61.8
		110	C	19.360	29.053	38.355	47.591	57.083	67.156	78.133	90.337	104.091	119.720	
			P	7.542	9.127	10.555	11.852	13.047	14.169	15.245	16.303	17.371	18.477	
			A	32.6	36.4	39.8	42.8	45.5	48.1	50.7	53.3	56.0	59.0	
		100	C	26.215	35.854	45.219	54.634	64.422	74.906	86.411	99.259	113.775	130.281	
			P	7.819	9.249	10.523	11.670	12.717	13.693	14.626	15.543	16.472	17.443	
			A	33.0	36.4	39.3	41.9	44.2	46.4	48.6	50.8	53.2	55.9	
90	C	32.173	41.834	51.337	61.007	71.166	82.138	94.246	107.815	123.167	140.626			
	P	7.927	9.213	10.346	11.354	12.265	13.108	13.909	14.697	15.500	16.347			
	A	33.0	35.9	38.4	40.6	42.6	44.4	46.3	48.2	50.3	52.6			
JLD5400L6C	60HNF93KE-TSK	54	130	C	3.283	14.429	25.345	36.296	47.550	59.374	72.035	85.800	100.937	117.712
				P	15.590	15.103	15.168	15.710	16.655	17.928	19.454	21.159	22.967	24.803
				A	55.0	54.4	54.9	56.3	58.6	61.7	65.3	69.5	74.1	79.0
			120	C	15.053	25.835	36.539	47.432	58.782	70.856	83.921	98.243	114.091	131.731
				P	14.831	14.494	14.668	15.277	16.248	17.504	18.972	20.576	22.242	23.895
				A	53.5	53.2	53.8	55.4	57.7	60.6	64.1	68.0	72.2	76.6
		110	C	24.761	35.268	45.852	56.779	68.316	80.731	94.290	109.262	125.911	144.507	
			P	14.013	13.814	14.083	14.746	15.728	16.955	18.351	19.843	21.354	22.811	
			A	51.5	51.4	52.2	53.8	56.0	58.8	62.1	65.7	69.5	73.4	
		100	C	32.683	43.007	53.562	64.613	76.429	89.276	103.421	119.132	136.675	156.318	
			P	13.152	13.076	13.428	14.132	15.114	16.298	17.610	18.975	20.318	21.565	
			A	49.1	49.2	50.2	51.8	54.0	56.6	59.6	62.9	66.3	69.7	
90	C	39.094	49.327	59.944	71.211	83.396	96.766	111.589	128.130	146.658	167.439			
	P	12.263	12.299	12.721	13.452	14.420	15.548	16.763	17.989	19.151	20.176			
	A	46.7	47.0	48.0	49.6	51.7	54.2	56.9	59.8	62.8	65.7			

Modelo	Compresor	H.P	TSC (°F)	TSE °F C=Capacidad kBtu's/h P=Potencia kW A= Amps.										
				-45	-40	-35	-30	-25	-20	-15	-10	-5	0	
JLD6000L6C	60JNF1ME-TSK	60	130	C	1,469	15,926	29,845	43,584	57,503	71,960	87,313	103,923	122,147	142,344
				P	16,098	16,437	17,191	18,306	19,727	21,399	23,266	25,274	27,367	29,490
				A	55.1	57.9	61.0	64.4	68.1	72.2	76.6	81.4	86.6	92.2
			120	C	16,208	30,097	43,649	57,221	71,173	85,863	101,650	118,894	137,952	159,183
				P	15,645	16,048	16,831	17,940	19,319	20,914	22,669	24,529	26,439	28,343
				A	54.9	57.6	60.5	63.7	67.2	70.9	75.0	79.4	84.1	89.1
			110	C	28,400	41,841	55,145	68,670	82,776	97,819	114,160	132,158	152,170	174,556
				P	15,071	15,529	16,333	17,428	18,757	20,266	21,901	23,604	25,322	27,000
				A	53.9	56.5	59.2	62.2	65.4	68.8	72.5	76.5	80.7	85.2
			100	C	38,376	51,490	64,667	78,265	92,644	108,161	125,176	144,047	165,133	188,793
				P	14,395	14,902	15,718	16,789	18,061	19,476	20,981	22,520	24,039	25,481
				A	52.4	54.9	57.4	60.2	63.1	66.2	69.5	73.1	76.8	80.8
			90	C	46,470	59,376	72,546	86,337	101,109	117,219	135,028	154,893	177,174	202,228
				P	13,639	14,185	15,005	16,046	17,250	18,564	19,931	21,298	22,608	23,806
				A	50.7	53.0	55.4	57.9	60.6	63.3	66.2	69.3	72.6	76.0

MODELO BLV

COMPRESOR COPELAND

R-449A | 230V

Modelo	Compresor	H.P	TSC (°F)	TSE °F C=Capacidad kBtu's/h P=Potencia kW A= Amps.													
				-5	0	5	10	15	20	25	30	35	40	45			
JLD3000M6D	3DS3R17ME-TFD	30	130	C	50.179	57.549	65.584	74.392	84.083	94.765	106.546	119.535	133.842	149.574	166.840		
				P	12.368	13.116	13.862	14.605	15.342	16.071	16.788	17.493	18.183	18.856	19.508		
				A	19.9	20.8	21.7	22.6	23.5	24.4	25.3	26.2	27.1	27.9	28.7		
			120	C	57.578	65.743	74.713	84.598	95.505	107.544	120.822	135.450	151.535	169.186	188.512		
				P	11.929	12.619	13.301	13.971	14.628	15.269	15.892	16.494	17.075	17.630	18.158		
				A	19.4	20.2	21.0	21.8	22.6	23.4	24.2	25.0	25.7	26.4	27.0		
			110	C	64.956	73.948	83.886	94.878	107.034	120.461	135.270	151.567	169.463	189.065	210.483		
				P	11.458	12.087	12.700	13.294	13.868	14.418	14.943	15.441	15.908	16.343	16.744		
				A	18.8	19.6	20.3	21.0	21.7	22.4	23.0	23.6	24.2	24.8	25.2		
		100	C	72.360	82.210	93.147	105.280	118.716	133.564	149.934	167.934	187.672	209.257	232.798			
			P	10.952	11.516	12.058	12.573	13.060	13.517	13.941	14.329	14.681	14.992	15.262			
			A	18.2	18.9	19.5	20.1	20.7	21.3	21.8	22.3	22.7	23.1	23.4			
		90	C	79.834	90.576	102.544	115.848	130.597	146.898	164.862	184.595	206.208	229.809	255.505			
			P	10.407	10.905	11.372	11.805	12.202	12.562	12.881	13.158	13.390	13.576	13.711			
			A	17.6	18.2	18.7	19.2	19.7	20.1	20.5	20.8	21.1	21.3	21.5			
		JLD4000M6D	4DBNR20ME-TSK	40	130	C	60.112	68.740	78.973	90.695	103.792	118.150	133.655	150.192	167.648	185.908	204.858
						P	15.551	16.444	17.352	18.269	19.187	20.097	20.992	21.865	22.708	23.512	24.271
						A	25.5	26.3	27.2	28.2	29.2	30.2	31.3	32.3	33.3	34.3	35.2
					120	C	70.383	80.048	91.425	104.400	118.858	134.686	151.769	169.992	189.243	209.406	230.367
						P	15.039	15.872	16.709	17.545	18.370	19.176	19.957	20.705	21.411	22.069	22.670
						A	24.9	25.7	26.6	27.5	28.4	29.3	30.2	31.0	31.8	32.5	33.1
					110	C	80.286	91.141	103.817	118.199	134.173	151.625	170.440	190.504	211.703	233.923	257.050
						P	14.476	15.240	15.997	16.741	17.464	18.158	18.815	19.427	19.988	20.489	20.922
						A	24.4	25.1	25.9	26.7	27.5	28.2	28.9	29.5	30.1	30.5	30.8
				100	C	90.127	102.327	116.457	132.400	150.044	169.273	189.975	212.034	235.336	259.768	285.215	
					P	13.864	14.548	15.216	15.859	16.470	17.041	17.565	18.033	18.438	18.773	19.029	
					A	23.8	24.5	25.2	25.8	26.5	27.0	27.5	27.8	28.2	28.2	28.2	
90	C			100.214	113.913	129.650	147.309	166.777	187.939	210.681	234.889	260.449	287.247	315.167			
	P			13.203	13.799	14.367	14.900	15.389	15.828	16.209	16.523	16.763	16.922	16.991			
	A			23.2	23.8	24.4	24.9	25.3	25.7	25.9	26.0	25.9	25.7	25.3			
JLD5000M6D	4DBNR22ME-TSK			50	130	C	63.930	73.331	84.460	97.187	111.381	126.914	143.656	161.475	180.243	199.829	220.103
						P	16.559	17.511	18.476	19.448	20.419	21.382	22.331	23.259	24.158	25.022	25.844
						A	28.7	29.6	30.6	31.7	32.8	34.0	35.2	36.3	37.5	38.5	39.6
					120	C	74.969	85.507	97.889	111.985	127.664	144.798	163.254	182.905	203.620	225.269	247.721
						P	16.006	16.895	17.786	18.671	19.545	20.399	21.227	22.022	22.777	23.486	24.141
						A	28.0	28.9	29.9	30.9	31.9	32.9	33.9	34.9	35.8	36.6	37.3
					110	C	85.872	97.692	111.472	127.082	144.390	163.268	183.585	205.212	228.018	251.874	276.649
						P	15.401	16.217	17.023	17.812	18.577	19.312	20.009	20.661	21.262	21.805	22.282
						A	27.4	28.2	29.1	30.0	30.9	31.7	32.5	33.2	33.8	34.3	34.6
				100	C	96.879	110.126	125.448	142.716	161.798	182.565	204.887	228.634	253.677	279.884	307.127	
					P	14.745	15.478	16.189	16.871	17.518	18.123	18.678	19.178	19.614	19.980	20.269	
					A	26.7	27.5	28.3	29.0	29.7	30.3	30.9	31.3	31.6	31.7	31.7	
		90	C	108.229	123.048	140.057	159.127	180.127	202.928	227.400	253.412	280.835	309.539	339.394			
			P	14.041	14.679	15.285	15.850	16.368	16.833	17.236	17.572	17.833	18.013	18.104			
			A	26.1	26.8	27.4	28.0	28.5	28.8	29.1	29.2	29.1	28.9	28.5			
		JLD6000M6D	4DJNR28ME-TSK	60	130	C	76.390	88.013	101.152	115.885	132.289	150.440	170.416	192.293	216.149	242.060	270.105
						P	19.351	20.717	22.087	23.452	24.799	26.119	27.400	28.631	29.802	30.901	31.917
						A	33.0	34.4	35.9	37.5	39.1	40.7	42.3	43.8	45.2	46.6	47.8
					120	C	88.881	102.325	117.405	134.198	152.781	173.231	195.624	220.038	246.551	275.238	306.177
						P	18.783	20.041	21.296	22.536	23.751	24.928	26.058	27.130	28.132	29.053	29.883
						A	32.4	33.7	35.0	36.4	37.8	39.3	40.6	42.0	43.2	44.3	45.3
					110	C	101.585	116.828	133.825	152.654	173.393	196.118	220.906	247.833	276.978	308.418	342.228
						P	18.147	19.292	20.423	21.532	22.606	23.634	24.606	25.510	26.336	27.073	27.710
						A	31.6	32.8	34.0	35.2	36.5	37.7	38.9	40.0	41.0	41.9	42.6
				100	C	114.637	131.654	150.545	171.388	194.259	219.235	246.394	275.812	307.567	341.735	378.393	
					P	17.435	18.458	19.460	20.429	21.355	22.226	23.033	23.763	24.406	24.950	25.386	
					A	30.8	31.8	32.9	34.0	35.0	36.1	37.1	38.0	38.7	39.4	39.8	
90	C			128.171	146.939	167.701	190.534	215.514	242.718	272.225	304.109	338.450	375.323	414.806			
	P			16.636	17.530	18.394	19.217	19.988	20.695	21.329	21.877	22.329	22.675	22.902			
	A			30.0	30.8	31.7	32.6	33.5	34.4	35.1	35.8	36.4	36.7	36.9			

Modelo	Compresor	H.P	TSC (°F)	TSE °F C=Capacidad kBtu's/h P=Potencia kW A= Amps.													
				-5	0	5	10	15	20	25	30	35	40	45			
JLD7000M6D	6D.HNR35ME-TSK	70	130	C	96,465	112,000	128,983	147,639	168,196	190,880	215,916	243,533	273,955	307,410	344,125		
				P	24,155	25,906	27,636	29,331	30,978	32,563	34,073	35,495	36,814	38,018	39,093		
				A	39.7	41.7	43.7	45.7	47.7	49.7	51.5	53.3	55.0	56.5	57.9		
			120	C	113,442	130,728	149,717	170,635	193,710	219,166	247,232	278,133	312,097	349,348	390,114		
				P	23,611	25,182	26,725	28,224	29,666	31,038	32,327	33,518	34,600	35,557	36,376		
				A	39.1	40.9	42.7	44.4	46.1	47.8	49.4	50.9	52.2	53.4	54.5		
			110	C	130,364	149,308	170,211	193,299	218,799	246,937	277,940	312,034	349,446	390,401	435,128		
				P	22,901	24,288	25,638	26,936	28,169	29,323	30,385	31,342	32,180	32,886	33,446		
				A	38.3	39.9	41.4	42.9	44.4	45.7	47.0	48.2	49.2	50.1	50.8		
			100	C	147,302	167,812	190,537	215,702	243,536	274,263	308,110	345,305	386,073	430,641	479,235		
				P	22,017	23,216	24,368	25,460	26,478	27,410	28,241	28,959	29,549	29,998	30,293		
				A	37.4	38.7	40.0	41.2	42.4	43.5	44.5	45.3	46.0	46.6	47.0		
		90	C	164,326	186,310	210,764	237,915	267,990	301,214	337,814	378,017	422,049	470,137	522,507			
			P	20,952	21,957	22,907	23,788	24,588	25,292	25,887	26,360	26,697	26,885	26,911			
			A	36.3	37.4	38.4	39.4	40.3	41.1	41.8	42.3	42.7	43.0	43.0			
		JLD8000M6D	6D.NR40ME-TSN	80	130	C	121,837	138,197	156,563	177,076	199,878	225,111	252,916	283,434	316,807	353,176	392,683
						P	29,818	31,832	33,843	35,833	37,786	39,687	41,520	43,267	44,913	46,441	47,836
						A	89.8	94.3	98.9	103.6	108.3	112.9	117.5	121.9	126.0	130.0	133.6
					120	C	140,772	160,103	181,680	205,643	232,133	261,293	293,264	328,187	366,204	407,456	452,085
						P	28,917	30,737	32,538	34,304	36,019	37,667	39,231	40,694	42,042	43,258	44,325
						A	87.7	91.8	95.9	100.0	104.1	108.1	111.9	115.5	118.9	122.0	124.8
					110	C	158,132	180,034	204,420	231,432	261,210	293,896	329,631	368,558	410,817	456,551	505,900
						P	27,788	29,409	30,996	32,534	34,005	35,395	36,685	37,861	38,906	39,804	40,539
						A	85.2	88.8	92.4	95.9	99.4	102.7	105.8	108.7	111.3	113.6	115.4
100	C				176,186	200,258	227,053	256,712	289,376	325,187	364,286	406,815	452,916	502,730	556,398		
	P				26,506	27,923	29,292	30,596	31,820	32,946	33,959	34,842	35,580	36,156	36,553		
	A				82.4	85.5	88.6	91.5	94.4	97.0	99.5	101.6	103.4	104.8	105.8		
90	C			197,203	223,044	251,846	283,751	318,900	357,435	399,497	445,228	494,769	548,262	605,848			
	P			25,146	26,355	27,501	28,567	29,538	30,396	31,127	31,713	32,138	32,387	32,443			
	A			79.5	82.1	84.7	87.1	89.3	91.3	93.0	94.3	95.3	95.9	95.9			

MODELO BLV

COMPRESOR COPELAND

R-404A | 460V

Modelo	Compresor	H.P	TSC (°F)	TSE °F C=Capacidad kBtu's/h P=Potencia kW A= Amps.													
				-5	0	5	10	15	20	25	30	35	40	45			
JLD3000M6C	3DS3R17ME-TFD	30	130	C	50,179	57,549	65,584	74,392	84,083	94,765	106,546	119,535	133,842	149,574	166,840		
				P	12,368	13,116	13,862	14,605	15,342	16,071	16,788	17,493	18,183	18,856	19,508		
				A	39.8	41.6	43.4	45.2	47.0	48.8	50.6	52.4	54.1	55.8	57.4		
			120	C	57,578	65,743	74,713	84,598	95,505	107,544	120,822	135,450	151,535	169,186	188,512		
				P	11,929	12,619	13,301	13,971	14,628	15,269	15,892	16,494	17,075	17,630	18,158		
				A	38.8	40.4	42.0	43.7	45.3	46.9	48.4	49.9	51.4	52.8	54.1		
			110	C	64,956	73,948	83,886	94,878	107,034	120,461	135,270	151,567	169,463	189,065	210,483		
				P	11,458	12,087	12,700	13,294	13,868	14,418	14,943	15,441	15,908	16,343	16,744		
				A	37.7	39.1	40.6	42.0	43.4	44.8	46.1	47.3	48.4	49.5	50.5		
		100	C	72,360	82,210	93,147	105,280	118,716	133,564	149,934	167,934	187,672	209,257	232,798			
			P	10,952	11,516	12,058	12,573	13,060	13,517	13,941	14,329	14,681	14,992	15,262			
			A	36.5	37.7	39.0	40.2	41.4	42.5	43.6	44.5	45.4	46.1	46.8			
		90	C	79,834	90,576	102,544	115,848	130,597	146,898	164,862	184,595	206,208	229,809	255,505			
			P	10,407	10,905	11,372	11,805	12,202	12,562	12,881	13,158	13,390	13,576	13,711			
			A	35.2	36.3	37.4	38.4	39.4	40.2	41.0	41.7	42.2	42.7	43.0			
		JLD4000M6C	4DBNR20ME-TSK	40	130	C	60,112	68,740	78,973	90,695	103,792	118,150	133,655	150,192	167,648	185,908	204,858
						P	15,551	16,444	17,352	18,269	19,187	20,097	20,992	21,865	22,708	23,512	24,271
						A	51.0	52.7	54.5	56.4	58.4	60.5	62.6	64.6	66.7	68.6	70.4
120	C				70,383	80,048	91,425	104,400	118,858	134,686	151,769	169,992	189,243	209,406	230,367		
	P				15,039	15,872	16,709	17,545	18,370	19,176	19,957	20,705	21,411	22,069	22,670		
	A				49.9	51.5	53.2	55.0	56.8	58.6	60.4	62.0	63.6	65.1	66.3		
110	C				80,286	91,141	103,817	118,199	134,173	151,625	170,440	190,504	211,703	233,923	257,050		
	P				14,476	15,240	15,997	16,741	17,464	18,158	18,815	19,427	19,988	20,489	20,922		
	A				48.7	50.2	51.8	53.4	55.0	56.4	57.8	59.1	60.1	61.0	61.6		
100	C			90,127	102,327	116,457	132,400	150,044	169,273	189,975	212,034	235,336	259,768	285,215			
	P			13,864	14,548	15,216	15,859	16,470	17,041	17,565	18,033	18,438	18,773	19,029			
	A			47.6	49.0	50.4	51.7	52.9	54.0	54.9	55.7	56.2	56.5	56.4			
90	C			100,214	113,913	129,650	147,309	166,777	187,939	210,681	234,889	260,449	287,247	315,167			
	P			13,203	13,799	14,367	14,900	15,389	15,828	16,209	16,523	16,763	16,922	16,991			
	A			46.5	47.7	48.8	49.8	50.7	51.3	51.8	52.0	51.9	51.4	50.6			
JLD5000M6C	4DBNR22ME-TSK			50	130	C	63,930	73,331	84,460	97,187	111,381	126,914	143,656	161,475	180,243	199,829	220,103
						P	16,559	17,511	18,476	19,448	20,419	21,382	22,331	23,259	24,158	25,022	25,844
						A	57.3	59.2	61.2	63.4	65.6	68.0	70.3	72.7	74.9	77.1	79.1
		120	C		74,969	85,507	97,889	111,985	127,664	144,798	163,254	182,905	203,620	225,269	247,721		
			P		16,006	16,895	17,786	18,671	19,545	20,399	21,227	22,022	22,777	23,486	24,141		
			A		56.1	57.9	59.8	61.8	63.8	65.9	67.9	69.8	71.5	73.1	74.5		
		110	C		85,872	97,692	111,472	127,082	144,390	163,268	183,585	205,212	228,018	251,874	276,649		
			P		15,401	16,217	17,023	17,812	18,577	19,312	20,009	20,661	21,262	21,805	22,282		
			A		54.8	56.5	58.2	60.0	61.8	63.4	65.0	66.4	67.6	68.6	69.3		
		100	C	96,879	110,126	125,448	142,716	161,798	182,565	204,887	228,634	253,677	279,884	307,127			
			P	14,745	15,478	16,189	16,871	17,518	18,123	18,678	19,178	19,614	19,980	20,269			
			A	53.5	55.0	56.6	58.1	59.5	60.7	61.8	62.6	63.2	63.5	63.4			
		90	C	108,229	123,048	140,057	159,127	180,127	202,928	227,400	253,412	280,835	309,539	339,394			
			P	14,041	14,679	15,285	15,850	16,368	16,833	17,236	17,572	17,833	18,013	18,104			
			A	52.2	53.6	54.8	56.0	56.9	57.7	58.2	58.4	58.3	57.8	56.9			
		JLD6000M6C	4DJNR28ME-TSK	60	130	C	76,390	88,013	101,152	115,885	132,289	150,440	170,416	192,293	216,149	242,060	270,105
						P	19,351	20,717	22,087	23,452	24,799	26,119	27,400	28,631	29,802	30,901	31,917
						A	66.0	68.8	71.8	75.0	78.2	81.4	84.5	87.6	90.5	93.2	95.6
120	C				88,881	102,325	117,405	134,198	152,781	173,231	195,624	220,038	246,551	275,238	306,177		
	P				18,783	20,041	21,296	22,536	23,751	24,928	26,058	27,130	28,132	29,053	29,883		
	A				64.7	67.3	70.0	72.8	75.7	78.5	81.3	83.9	86.4	88.6	90.5		
110	C				101,585	116,828	133,825	152,654	173,393	196,118	220,906	247,833	276,978	308,418	342,228		
	P				18,147	19,292	20,423	21,532	22,606	23,634	24,606	25,510	26,336	27,073	27,710		
	A				63.3	65.6	68.0	70.5	73.0	75.5	77.8	80.0	82.0	83.8	85.2		
100	C			114,637	131,654	150,545	171,388	194,259	219,235	246,394	275,812	307,567	341,735	378,393			
	P			17,435	18,458	19,460	20,429	21,355	22,226	23,033	23,763	24,406	24,950	25,386			
	A			61.7	63.7	65.8	67.9	70.1	72.2	74.1	75.9	77.5	78.7	79.6			
90	C			128,171	146,939	167,701	190,534	215,514	242,718	272,225	304,109	338,450	375,323	414,806			
	P			16,636	17,530	18,394	19,217	19,988	20,695	21,329	21,877	22,329	22,675	22,902			
	A			59.9	61.6	63.4	65.3	67.0	68.7	70.3	71.6	72.7	73.5	73.9			

Modelo	Compresor	H.P	TSC (°F)	TSE °F C=Capacidad kBtu's/h P=Potencia kW A= Amps.													
				-5	0	5	10	15	20	25	30	35	40	45			
JLD7000M6C	60HNR35ME-TSK	70	130	C	96,465	112,000	128,983	147,639	168,196	190,880	215,916	243,533	273,955	307,410	344,125		
				P	24,155	25,906	27,636	29,331	30,978	32,563	34,073	35,495	36,814	38,018	39,093		
				A	79.4	83.4	87.4	91.5	95.4	99.3	103.1	106.6	110.0	113.1	115.9		
			120	C	113,442	130,728	149,717	170,635	193,710	219,166	247,232	278,133	312,097	349,348	390,114		
				P	23,611	25,182	26,725	28,224	29,666	31,038	32,327	33,518	34,600	35,557	36,376		
				A	78.2	81.8	85.4	88.9	92.3	95.6	98.8	101.7	104.4	106.8	109.0		
			110	C	130,364	149,308	170,211	193,299	218,799	246,937	277,940	312,034	349,446	390,401	435,128		
				P	22,901	24,288	25,638	26,936	28,169	29,323	30,385	31,342	32,180	32,886	33,446		
				A	76.7	79.8	82.8	85.8	88.7	91.5	94.0	96.4	98.4	100.2	101.6		
		100	C	147,302	167,812	190,537	215,702	243,536	274,263	308,110	345,305	386,073	430,641	479,235			
			P	22,017	23,216	24,368	25,460	26,478	27,410	28,241	28,959	29,549	29,998	30,293			
			A	74.7	77.4	80.0	82.4	84.8	87.0	88.9	90.7	92.1	93.2	93.9			
		90	C	164,326	186,310	210,764	237,915	267,990	301,214	337,814	378,017	422,049	470,137	522,507			
			P	20,952	21,957	22,907	23,788	24,588	25,292	25,887	26,360	26,697	26,885	26,911			
			A	72.6	74.7	76.8	78.8	80.6	82.2	83.6	84.7	85.5	85.9	86.0			
		JLD8000M6C	60JNR40ME-TSN	80	130	C	121,837	138,197	156,563	177,076	199,878	225,111	252,916	283,434	316,807	353,176	392,683
						P	29,818	31,832	33,843	35,833	37,786	39,687	41,520	43,267	44,913	46,441	47,836
						A	179.5	188.6	197.9	207.2	216.6	225.9	235.0	243.7	252.1	260.0	267.2
120	C				140,772	160,103	181,680	205,643	232,133	261,293	293,264	328,187	366,204	407,456	452,085		
	P				28,917	30,737	32,538	34,304	36,019	37,667	39,231	40,694	42,042	43,258	44,325		
	A				175.4	183.5	191.8	200.0	208.2	216.1	223.8	231.1	237.9	244.1	249.5		
110	C				158,132	180,034	204,420	231,432	261,210	293,896	329,631	368,558	410,817	456,551	505,900		
	P				27,788	29,409	30,996	32,534	34,005	35,395	36,685	37,861	38,906	39,804	40,539		
	A				170.4	177.5	184.7	191.8	198.8	205.4	211.7	217.5	222.6	227.1	230.9		
100	C			176,186	200,258	227,053	256,712	289,376	325,187	364,286	406,815	452,916	502,730	556,398			
	P			26,506	27,923	29,292	30,596	31,820	32,946	33,959	34,842	35,580	36,156	36,553			
	A			164.8	171.0	177.1	183.1	188.8	194.1	198.9	203.2	206.8	209.6	211.5			
90	C			197,203	223,044	251,846	283,751	318,900	357,435	399,497	445,228	494,769	548,262	605,848			
	P			25,146	26,355	27,501	28,567	29,538	30,396	31,127	31,713	32,138	32,387	32,443			
	A			159.1	164.3	169.4	174.1	178.6	182.5	185.9	188.7	190.7	191.8	191.9			

MODELO BLV

COMPRESOR COPELAND

R-404A | 230V

Modelo	Compresor	H.P	TSC (°F)	TSE °F C=Capacidad kBtu's/h P=Potencia kW A= Amps.												
				-45	-40	-35	-30	-25	-20	-15	-10	-5	0			
JLD2400L6D	40BNF54KE-TSK	24	130	C	255	8,099	15,230	21,874	28,259	34,610	41,154	48,119	55,730	64,214		
				P	3,997	5,745	7,315	8,727	10,004	11,165	12,233	13,229	14,173	15,087		
				A	10.4	12.2	13.8	15.4	16.8	18.2	19.5	20.7	21.9	23.1		
			120	C	8,089	15,398	22,176	28,652	35,050	41,598	48,522	56,049	64,406	73,819		
				P	5,255	6,709	8,005	9,166	10,211	11,163	12,042	12,870	13,668	14,457		
				A	11.8	13.3	14.6	15.9	17.1	18.2	19.3	20.3	21.4	22.4		
			110	C	14,674	21,577	28,133	34,568	41,109	47,983	55,416	63,635	72,866	83,337		
				P	6,051	7,247	8,307	9,253	10,104	10,884	11,612	12,309	12,998	13,700		
				A	12.6	13.8	14.9	16.0	16.9	17.9	18.8	19.7	20.5	21.4		
		100	C	20,369	26,995	33,457	39,981	46,794	54,123	62,194	71,234	81,469	93,126			
			P	6,480	7,456	8,317	9,084	9,779	10,423	11,037	11,641	12,258	12,909			
			A	13.0	14.0	14.9	15.7	16.5	17.3	18.1	18.8	19.6	20.4			
		90	C	25,530	32,009	38,506	45,248	52,462	60,375	69,213	79,202	90,570	103,543			
			P	6,637	7,430	8,129	8,756	9,331	9,877	10,413	10,962	11,544	12,181			
			A	13.2	13.9	14.7	15.3	16.0	16.7	17.3	18.0	18.7	19.5			
		JLD3000L6D	40HNF63KE-TSK	30	130	C	10,625	16,801	22,854	28,964	35,311	42,073	49,430	57,561	66,646	76,863
						P	7,304	8,799	10,192	11,495	12,724	13,894	15,019	16,113	17,192	18,270
						A	15.4	16.8	18.2	19.5	20.9	22.3	23.6	25.0	26.3	27.7
120	C				14,296	20,942	27,541	34,270	41,310	48,839	57,037	66,083	76,156	87,436		
	P				7,841	9,149	10,360	11,488	12,548	13,554	14,522	15,465	16,399	17,338		
	A				16.0	17.2	18.4	19.6	20.8	21.9	23.1	24.2	25.4	26.6		
110	C				18,970	26,101	33,257	40,619	48,364	56,673	65,725	75,698	86,772	99,127		
	P				8,177	9,324	10,379	11,358	12,275	13,144	13,981	14,800	15,615	16,441		
	A				16.3	17.3	18.4	19.4	20.4	21.4	22.4	23.4	24.4	25.4		
100	C			24,487	32,115	39,842	47,848	56,312	65,413	75,331	86,245	98,333	111,776			
	P			8,331	9,343	10,269	11,125	11,925	12,684	13,416	14,136	14,859	15,598			
	A			16.3	17.3	18.2	19.1	20.0	20.8	21.7	22.5	23.4	24.2			
90	C			30,686	38,823	47,134	55,797	64,993	74,899	85,696	97,562	110,678	125,222			
	P			8,323	9,226	10,050	10,809	11,519	12,193	12,847	13,494	14,150	14,830			
	A			16.2	17.1	17.9	18.7	19.5	20.2	21.0	21.7	22.5	23.2			
JLD4400L6D	40JNF76KE-TSK			44	130	C	5,940	14,834	23,470	32,014	40,635	49,500	58,777	68,632	79,235	90,752
						P	7,315	9,363	11,251	12,997	14,616	16,127	17,545	18,889	20,176	21,421
						A	15.6	17.9	20.0	22.0	23.9	25.6	27.3	28.9	30.5	32.0
		120	C		14,930	23,557	32,096	40,714	49,580	58,860	68,722	79,334	90,863	103,478		
			P		8,401	10,158	11,773	13,263	14,645	15,937	17,155	18,317	19,440	20,540		
			A		17.0	18.9	20.6	22.3	23.9	25.4	26.8	28.2	29.6	31.0		
		110	C		22,737	31,384	40,113	49,092	58,489	68,471	79,205	90,860	103,603	117,601		
			P		9,094	10,594	11,971	13,242	14,423	15,532	16,585	17,601	18,595	19,585		
			A		17.9	19.4	20.9	22.3	23.6	24.9	26.1	27.4	28.6	29.9		
		100	C	29,517	38,470	47,676	57,302	67,517	78,487	90,381	103,366	117,609	133,278			
			P	9,456	10,736	11,910	12,997	14,012	14,973	15,898	16,802	17,704	18,620			
			A	18.4	19.7	20.9	22.0	23.1	24.2	25.3	26.4	27.5	28.7			
		90	C	35,423	44,969	54,939	65,499	76,819	89,064	102,404	117,005	133,034	150,661			
			P	9,550	10,644	11,652	12,590	13,475	14,325	15,156	15,985	16,829	17,706			
			A	18.6	19.6	20.6	21.5	22.5	23.4	24.4	25.4	26.5	27.6			
		JLD5400L6D	60HNF93KE-TSK	54	130	C	12,676	21,422	30,885	41,062	51,947	63,535	75,821	88,801	102,469	116,820
						P	8,857	11,205	13,453	15,603	17,661	19,628	21,510	23,310	25,031	26,677
						A	21.5	23.6	25.7	27.9	30.0	32.2	34.3	36.5	38.6	40.7
120	C				22,887	31,572	41,169	51,674	63,083	75,389	88,588	102,676	117,647	133,496		
	P				10,445	12,428	14,329	16,153	17,903	19,582	21,195	22,745	24,236	25,671		
	A				22.9	24.6	26.5	28.3	30.2	32.0	33.9	35.8	37.7	39.5		
110	C				32,207	40,970	50,840	61,813	73,884	87,048	101,300	116,634	133,047	150,533		
	P				11,363	13,029	14,632	16,178	17,668	19,108	20,501	21,849	23,158	24,431		
	A				23.6	25.1	26.7	28.3	29.9	31.5	33.2	34.8	36.4	38.1		
100	C			40,909	49,888	60,171	71,751	84,623	98,784	114,227	130,949	148,943	168,205			
	P			11,760	13,157	14,511	15,826	17,106	18,355	19,575	20,771	21,947	23,105			
	A			23.9	25.2	26.5	27.9	29.3	30.7	32.2	33.6	35.1	36.5			
90	C			49,263	58,600	69,433	81,760	95,573	110,870	127,644	145,891	165,606	186,783			
	P			11,784	12,960	14,114	15,248	16,366	17,471	18,568	19,660	20,750	21,843			
	A			23.9	25.0	26.1	27.3	28.6	29.8	31.1	32.4	33.7	35.0			

Modelo	Compresor	H.P	TSC (°F)	TSE °F C=Capacidad kBtu's/h P=Potencia kW A= Amps.										
				-45	-40	-35	-30	-25	-20	-15	-10		-5	0
JLD6000L6D	6DJNF1ME-TSK	60	130	C	14,722	24,477	34,558	45,119	56,312	68,290	81,205	95,210	110,459	127,102
				P	12,533	15,010	17,417	19,760	22,047	24,286	26,482	28,645	30,780	32,895
				A	25.8	28.4	31.0	33.7	36.4	39.1	41.8	44.5	47.3	50.1
			120	C	23,962	33,875	44,378	55,624	67,764	80,952	95,340	111,081	128,327	147,231
				P	13,542	15,728	17,855	19,932	21,965	23,961	25,929	27,874	29,804	31,727
				A	26.9	29.2	31.5	33.9	36.2	38.7	41.1	43.6	46.1	48.6
			110	C	33,357	43,514	54,524	66,538	79,710	94,192	110,138	127,698	147,027	168,276
				P	14,152	16,068	17,938	19,770	21,570	23,347	25,106	26,856	28,603	30,355
				A	27.5	29.5	31.5	33.6	35.7	37.9	40.0	42.2	44.5	46.8
			100	C	42,515	53,001	64,601	77,469	91,758	107,619	125,206	144,671	166,166	189,845
				P	14,427	16,095	17,730	19,338	20,928	22,506	24,079	25,655	27,241	28,844
				A	27.8	29.5	31.2	33.0	34.9	36.8	38.7	40.7	42.7	44.8
			90	C	51,045	61,943	74,219	88,025	103,515	120,839	140,152	161,606	185,353	211,546
				P	14,432	15,874	17,295	18,702	20,102	21,504	22,913	24,337	25,783	27,259
				A	27.8	29.2	30.7	32.3	33.9	35.6	37.3	39.0	40.9	42.7

MODELO BLV

COMPRESOR COPELAND

R-404A | 460V

Modelo	Compresor	H.P	TSC (°F)	TSE °F C=Capacidad kBtu's/h P=Potencia kW A= Amps.										
				-45	-40	-35	-30	-25	-20	-15	-10	-5	0	
JLD2400L6C	40BNF54KE-TSK	24	130	C	255	8,099	15,230	21,874	28,259	34,610	41,154	48,119	55,730	64,214
				P	3,997	5,745	7,315	8,727	10,004	11,165	12,233	13,229	14,173	15,087
				A	20.8	24.4	27.7	30.8	33.7	36.4	39.0	41.4	43.8	46.1
			120	C	8,089	15,398	22,176	28,652	35,050	41,598	48,522	56,049	64,406	73,819
				P	5,255	6,709	8,005	9,166	10,211	11,163	12,042	12,870	13,668	14,457
				A	23.6	26.5	29.2	31.8	34.2	36.4	38.6	40.7	42.7	44.7
		110	C	14,674	21,577	28,133	34,568	41,109	47,983	55,416	63,635	72,866	83,337	
			P	6,051	7,247	8,307	9,253	10,104	10,884	11,612	12,309	12,998	13,700	
			A	25.2	27.6	29.8	31.9	33.9	35.8	37.6	39.3	41.1	42.8	
			C	20,369	26,995	33,457	39,981	46,794	54,123	62,194	71,234	81,469	93,126	
			P	6,480	7,456	8,317	9,084	9,779	10,423	11,037	11,641	12,258	12,909	
			A	26.0	28.0	29.8	31.4	33.1	34.6	36.1	37.7	39.2	40.8	
JLD3000L6C	40HNF63KE-TSK	30	130	C	10,625	16,801	22,854	28,964	35,311	42,073	49,430	57,561	66,646	76,863
				P	7,304	8,799	10,192	11,495	12,724	13,894	15,019	16,113	17,192	18,270
				A	30.8	33.6	36.3	39.1	41.8	44.5	47.2	49.9	52.7	55.4
			120	C	14,296	20,942	27,541	34,270	41,310	48,839	57,037	66,083	76,156	87,436
				P	7,841	9,149	10,360	11,488	12,548	13,554	14,522	15,465	16,399	17,338
				A	32.0	34.4	36.8	39.2	41.5	43.8	46.1	48.5	50.8	53.1
		110	C	18,970	26,101	33,257	40,619	48,364	56,673	65,725	75,698	86,772	99,127	
			P	8,177	9,324	10,379	11,358	12,275	13,144	13,981	14,800	15,615	16,441	
			A	32.6	34.7	36.8	38.8	40.8	42.8	44.8	46.8	48.8	50.8	
			C	24,487	32,115	39,842	47,848	56,312	65,413	75,331	86,245	98,333	111,776	
			P	8,331	9,343	10,269	11,125	11,925	12,684	13,416	14,136	14,859	15,598	
			A	32.6	34.5	36.4	38.2	39.9	41.6	43.3	45.1	46.8	48.5	
JLD4400L6C	40INF76KE-TSK	44	130	C	30,686	38,823	47,134	55,797	64,993	74,899	85,696	97,562	110,678	125,222
				P	8,323	9,226	10,050	10,809	11,519	12,193	12,847	13,494	14,150	14,830
				A	32.4	34.1	35.8	37.4	38.9	40.5	42.0	43.5	44.9	46.4
			120	C	5,940	14,834	23,470	32,014	40,635	49,500	58,777	68,632	79,235	90,752
				P	7,315	9,363	11,251	12,997	14,616	16,127	17,545	18,889	20,176	21,421
				A	31.2	35.8	40.0	44.0	47.7	51.2	54.6	57.8	61.0	64.0
		110	C	14,930	23,557	32,096	40,714	49,580	58,860	68,722	79,334	90,863	103,478	
			P	8,401	10,158	11,773	13,263	14,645	15,937	17,155	18,317	19,440	20,540	
			A	33.9	37.7	41.3	44.6	47.8	50.8	53.7	56.5	59.2	62.0	
			C	22,737	31,384	40,113	49,092	58,489	68,471	79,205	90,860	103,603	117,601	
			P	9,094	10,594	11,971	13,242	14,423	15,532	16,585	17,601	18,595	19,585	
			A	35.7	38.9	41.8	44.6	47.2	49.8	52.3	54.7	57.2	59.8	
JLD5400L6C	60HNF93KE-TSK	54	130	C	29,517	38,470	47,676	57,302	67,517	78,487	90,381	103,366	117,609	133,278
				P	9,456	10,736	11,910	12,997	14,012	14,973	15,898	16,802	17,704	18,620
				A	36.8	39.3	41.7	44.0	46.2	48.4	50.6	52.8	55.1	57.5
			120	C	35,423	44,969	54,939	65,499	76,819	89,064	102,404	117,005	133,034	150,661
				P	9,550	10,644	11,652	12,590	13,475	14,325	15,156	15,985	16,829	17,706
				A	37.1	39.2	41.1	43.0	44.9	46.8	48.7	50.8	52.9	55.3
		110	C	12,676	21,422	30,885	41,062	51,947	63,535	75,821	88,801	102,469	116,820	
			P	8,857	11,205	13,453	15,603	17,661	19,628	21,510	23,310	25,031	26,677	
			A	43.0	47.2	51.4	55.7	60.0	64.4	68.7	73.0	77.2	81.4	
			C	22,887	31,572	41,169	51,674	63,083	75,389	88,588	102,676	117,647	133,496	
			P	10,445	12,428	14,329	16,153	17,903	19,582	21,195	22,745	24,236	25,671	
			A	45.7	49.3	52.9	56.6	60.3	64.1	67.8	71.6	75.3	79.0	
JLD5400L6C	60HNF93KE-TSK	54	110	C	32,207	40,970	50,840	61,813	73,884	87,048	101,300	116,634	133,047	150,533
				P	11,363	13,029	14,632	16,178	17,668	19,108	20,501	21,849	23,158	24,431
				A	47.3	50.3	53.4	56.6	59.8	63.0	66.3	69.6	72.9	76.1
			100	C	40,909	49,888	60,171	71,751	84,623	98,784	114,227	130,949	148,943	168,205
				P	11,760	13,157	14,511	15,826	17,106	18,355	19,575	20,771	21,947	23,105
				A	47.9	50.4	53.1	55.8	58.6	61.4	64.3	67.2	70.1	73.0
		90	C	49,263	58,600	69,433	81,760	95,573	110,870	127,644	145,891	165,606	186,783	
			P	11,784	12,960	14,114	15,248	16,366	17,471	18,568	19,660	20,750	21,843	
			A	47.8	50.0	52.3	54.7	57.1	59.6	62.2	64.8	67.4	70.1	

Modelo	Compresor	H.P	TSC (°F)	TSE °F C=Capacidad kBtu's/h P=Potencia kW A= Amps.										
				-45	-40	-35	-30	-25	-20	-15	-10	-5	0	
JLD6000L6C	60JNF1ME-TSK	60	130	C	14,722	24,477	34,558	45,119	56,312	68,290	81,205	95,210	110,459	127,102
				P	12,533	15,010	17,417	19,760	22,047	24,286	26,482	28,645	30,780	32,895
				A	51.5	56.7	62.0	67.4	72.7	78.1	83.6	89.1	94.6	100.2
			120	C	23,962	33,875	44,378	55,624	67,764	80,952	95,340	111,081	128,327	147,231
				P	13,542	15,728	17,855	19,932	21,965	23,961	25,929	27,874	29,804	31,727
				A	53.7	58.3	63.0	67.7	72.5	77.3	82.2	87.1	92.1	97.2
			110	C	33,357	43,514	54,524	66,538	79,710	94,192	110,138	127,698	147,027	168,276
				P	14,152	16,068	17,938	19,770	21,570	23,347	25,106	26,856	28,603	30,355
				A	55.0	59.0	63.0	67.2	71.4	75.7	80.1	84.5	89.0	93.5
			100	C	42,515	53,001	64,601	77,469	91,758	107,619	125,206	144,671	166,166	189,845
				P	14,427	16,095	17,730	19,338	20,928	22,506	24,079	25,655	27,241	28,844
				A	55.5	58.9	62.5	66.1	69.8	73.6	77.4	81.4	85.4	89.5
			90	C	51,045	61,943	74,219	88,025	103,515	120,839	140,152	161,606	185,353	211,546
				P	14,432	15,874	17,295	18,702	20,102	21,504	22,913	24,337	25,783	27,259
				A	55.5	58.4	61.4	64.6	67.8	71.1	74.6	78.1	81.7	85.4

MODELO BLV

COMPRESOR COPELAND

R-404A | 230V

67

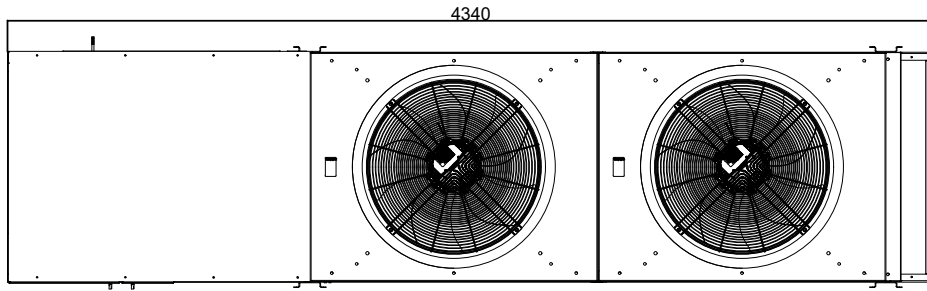

VISTA PLANTA

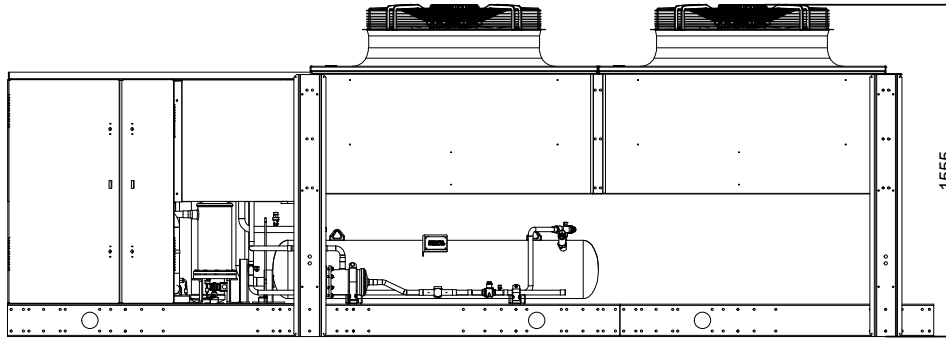

VISTA FRONTAL

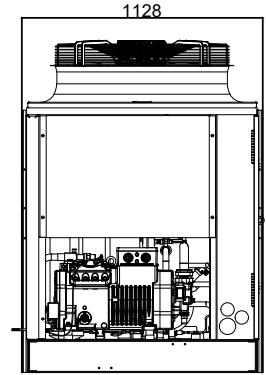

VISTA LAT. IZQUIERDA

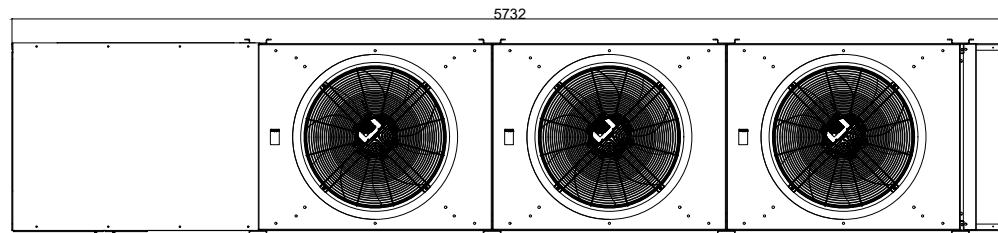

VISTA PLANTA

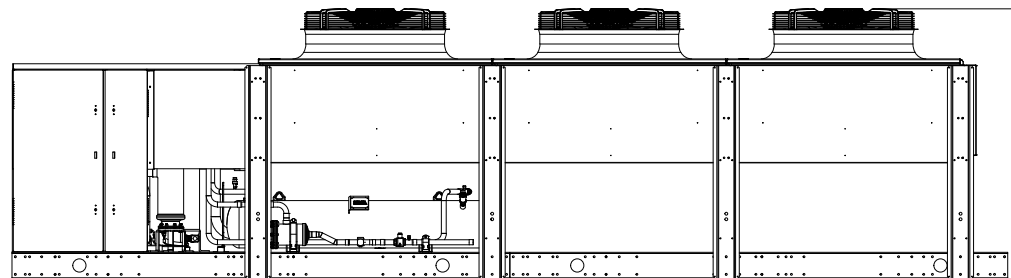

VISTA FRONTAL

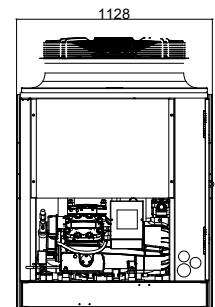

VISTA LAT. IZQUIERDA

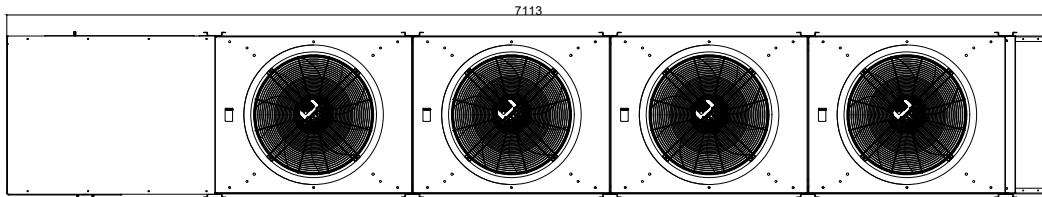

VISTA PLANTA

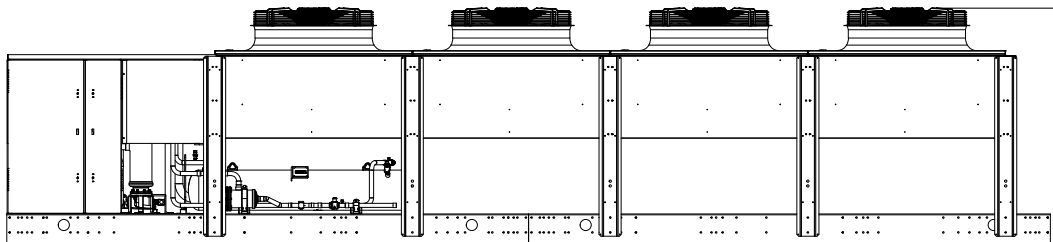

VISTA FRONTAL

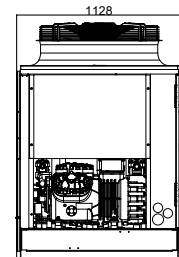

VISTA LAT. IZQUIERDA

UNIDAD CONDENSADORA BLV COMPRESORES SEMIHERMETICOS

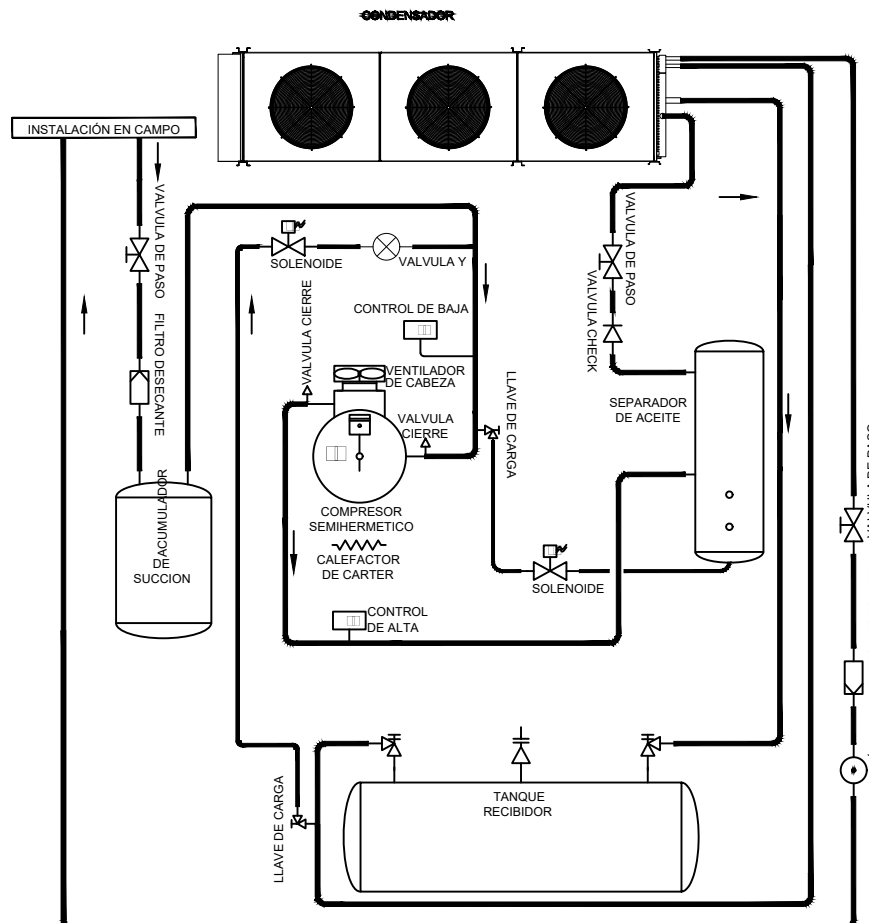

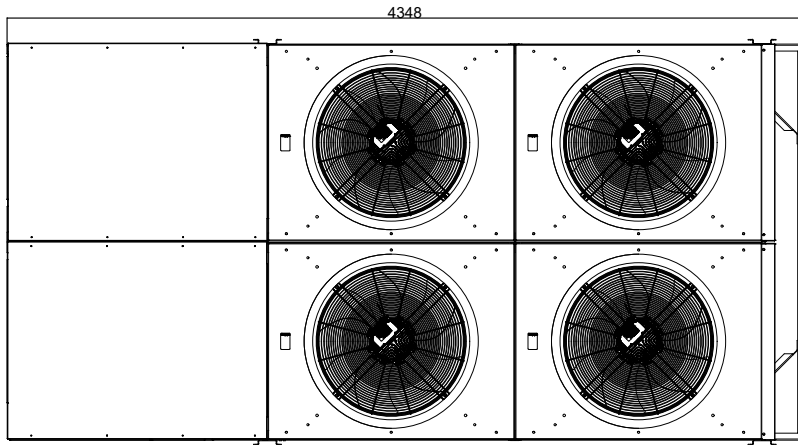

VISTA PLANTA

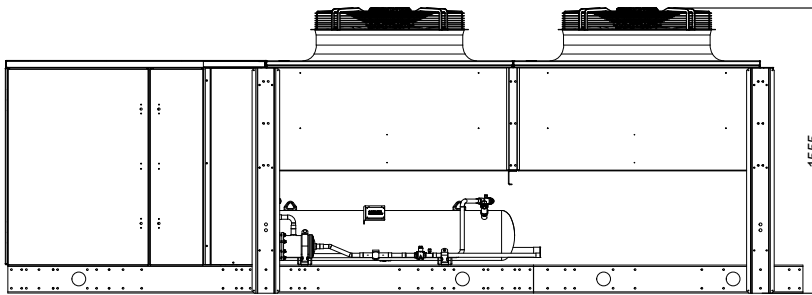

VISTA FRONTAL



VISTA LAT. IZQUIERDA

JLD | DIMENSIONES | 66,70,80 MEDIA 88 BAJA

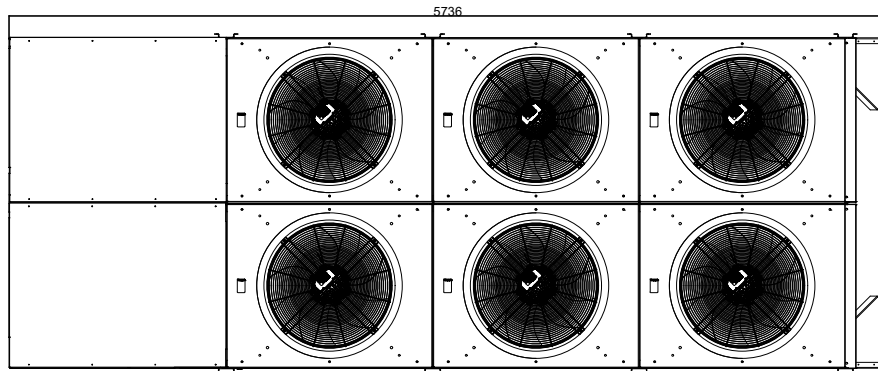

VISTA PLANTA

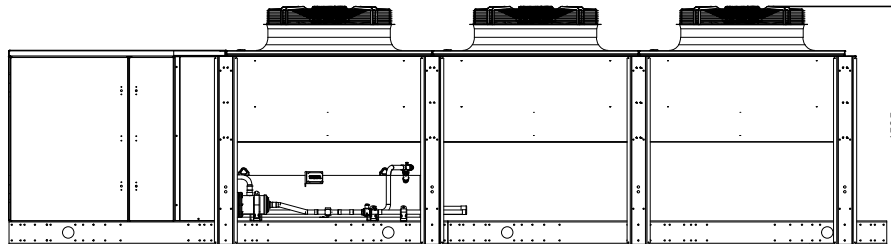

VISTA FRONTAL

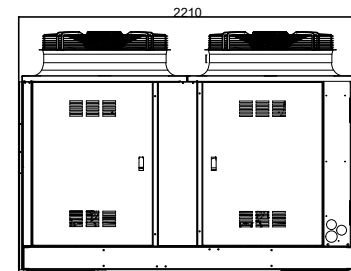

VISTA LAT. IZQUIERDA

Dimensiones: mm

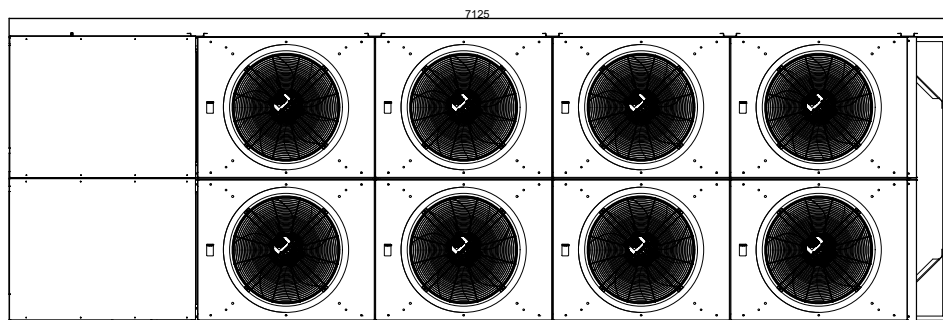

VISTA PLANTA

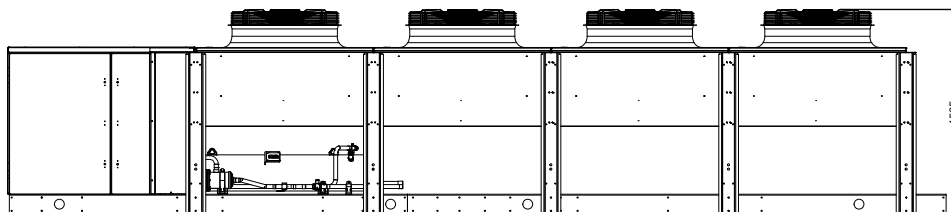

VISTA FRONTAL

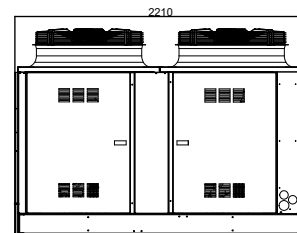

VISTA LAT. IZQUIERDA

UNIDAD CONDENSADORA JLD
COMPRESORES SEMIHERMETICOS

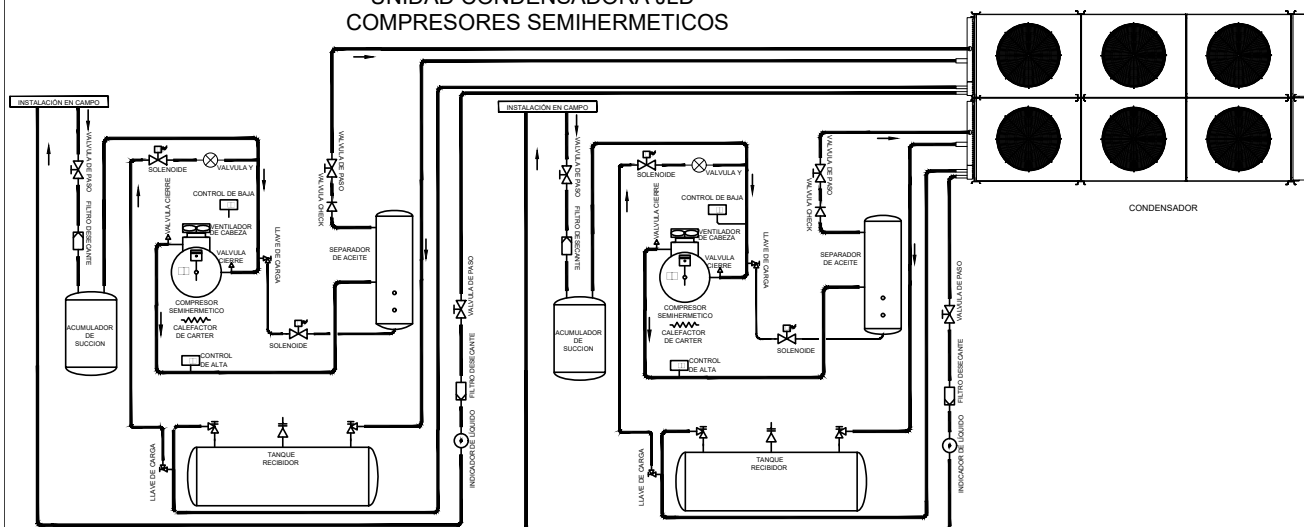

Dimensiones: mm

UNIDADES CONDENSADORAS
BLV Y JLD

COMPRESOR	DESCARGA	LÍQUIDO	SUCCIÓN	ACEITE	EQUIPO	CONTROL	CHASIS	OTROS	OPCIONALES
									ELÉCTRICO
Semihermético	Separador de aceite (Centrifugo)	Filtro desecante reemplazable para la línea de líquido	Acumulador de succión	Carga de aceite para separador	Bus de alimentación.	Tarjeta control servicemate	Base de lamina de acero galvanizado	Pads de hule para la unidad condensadora	KIT 1: Inyección de líquido para modelos de media temperatura
Calefactor de Carter	Válvula de paso con acceso a servicio	Inyección de líquido para modelos de baja temperatura	Filtro desecante reemplazable para la línea de succión	Línea de retorno de aceite	Contactador y guardamotor individual por compresor	Alambrado con código de color y número.	Lamina galvanizada prepintada a prueba de intemperie	Etiquetas con marca y tipo de aceite y refrigerante.	Sensores y transductores KE2.
Control de baja ajustable	Válvula Check	Indicador de líquido y humedad	Válvula de paso con acceso a servicio		Contactador general de protección para todos los ventiladores	Monitor de Falla de Fase		Sistema con carga seca de nitrógeno a 100 psi.	
Control de alta ajustable	Condensador cobre y aluminio Bohn gold	Tanque recibidor con dispositivo de seguridad	Aislamiento para línea de succión de espesor		Interruptor para transformador de control (solo si es 460V)	Interruptor Control			
Ventilador de cabeza (en baja temp).	Motores EC. EBM 800mm	Válvula de paso con acceso a servicio			Fusibles para cada ventilador	Toggle Switch para compresor			
Control diferencial de aceite (en comp. Con bomba de aceite)					Supresor de picos	Toggle Switch para sistema de bombeo completo (pump down)			
						Tarjeta de control KE2			

CONFIGURA TU EQUIPO EN:

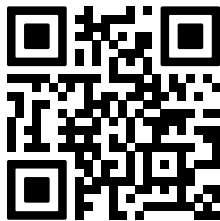

COMPRESOR	DESCARGA	LÍQUIDO	SUCCIÓN	ACEITE	EQUIPO	CONTROL	CHASIS	OTROS	OPCIONALES
									ELÉCTRICO
Semihermético	Separador de aceite (Centrifugo)	Filtro desecante reemplazable para la línea de líquido	Acumulador de succión	Carga de aceite para separador	Bus de alimentación.	Tarjeta control servicemate	Base de lamina de acero galvanizado	Pads de hule para la unidad condensadora	KIT 1: Inyección de líquido para modelos de media temperatura
Calefactor de Carter	Válvula de paso con acceso a servicio	Inyección de líquido para modelos de baja temperatura	Filtro desecante reemplazable para la línea de succión	Línea de retorno de aceite	Contacto y guardamotor individual por compresor	Alambrado con código de color y número.	Lamina galvanizada prepintada a prueba de intemperie	Etiquetas con marca y tipo de aceite y refrigerante.	Sensores y transductores KE2.
Control de baja ajustable	Válvula Check	Indicador de líquido y humedad	Válvula de paso con acceso a servicio		Contacto general de protección para todos los motores	Monitor de Falla de Fase		Sistema con carga seca de nitrógeno a 100 psi.	
Control de alta ajustable	Condensador cobre y aluminio Bohn gold	Tanque recibidor con dispositivo de seguridad	Aislamiento para línea de succión de espesor		Interruptor para transformador de control (solo si es 460V)	Interruptor Control			
Ventilador de cabeza (en baja temp).	Motores EC. EBM 800mm	Válvula de paso con acceso a servicio			Fusibles para cada motor	Toggle Switch para compresor			
Control diferencial de aceite (en comp. Con bomba de aceite)					Supresor de picos	Toggle Switch para sistema de bombeo completo(pump down)			
						Tarjeta de control KE2			

CONFIGURA TU EQUIPO EN:

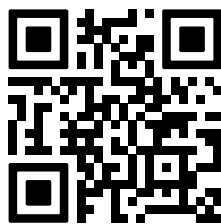



Call Center:
5000 5105 Ciudad de México
01 800 228 2046 Resto del país
Visita www.bohn.com.mx
enlacebohn@cft.com.mx

Boletín UCCD-1, Publicado OCTUBRE, 2024
Sustituye a BCT-062

BOHN se reserva el derecho de hacer cambios en sus especificaciones en cualquier momento, sin previo aviso y sin ninguna responsabilidad con los compradores, propietarios del equipo que previamente se les ha vendido.
Rev 2.8

Oficinas Corporativas

Bosques de Alisos No. 47-A, Piso 5
Col. Bosques de las Lomas
México, DF. C.P. 05120
Tel: +52 55 5000 5100

Planta Querétaro

Acceso II, Calle 2 No. 48
Parque Industrial Benito Juárez
Querétaro, Qro. C.P. 76120
Tel: +52 442 296 4500

Planta Mérida

Tablaje con número
catastral 34983,
Tixcacal, Mérida
Tel: +52 999 9463483

Planta Monterrey

Parque Industrial Finsa Santa Catarina
Carretera a García Km. 3.0
Santa Catarina, N.L.
Tel: +52 55 5000 8505

Guadalajara

Av. Chapultepec No.15 Piso 16 A
Col. Ladrón de Guevara
Guadalajara, Jal.
C.P. 44600
Tel. +52 33 4624 0080

Mazatlán, Sinaloa

San Alfonso #5006
Fracc. Real del Valle
Mazatlán Sinaloa
C.P. 8212
Tel: +52 667 752 0700
Cel: +52 667 791 5336

Tijuana

Camino del Rey Oeste # 5459-2
Privada Capri # 2
Residencial Colinas del Rey
Tijuana BC, C.P. 22170
Tel: +52 664 900 3830
Cel: +52 664 674 1677